

SENSO8 LoRaWAN Distance Sensor User Guide

Introduction	2
Sensor Setup	2
Installation and Connection	3
Operating Instruction	4
LED Indicator	4
Device Status	5
Error Status.....	5
Sensor Operation	5
Configurable Sensor Settings	5
Troubleshooting Guide	6
Revision History	6

Introduction

Applicable Model:

- LRS20LDO

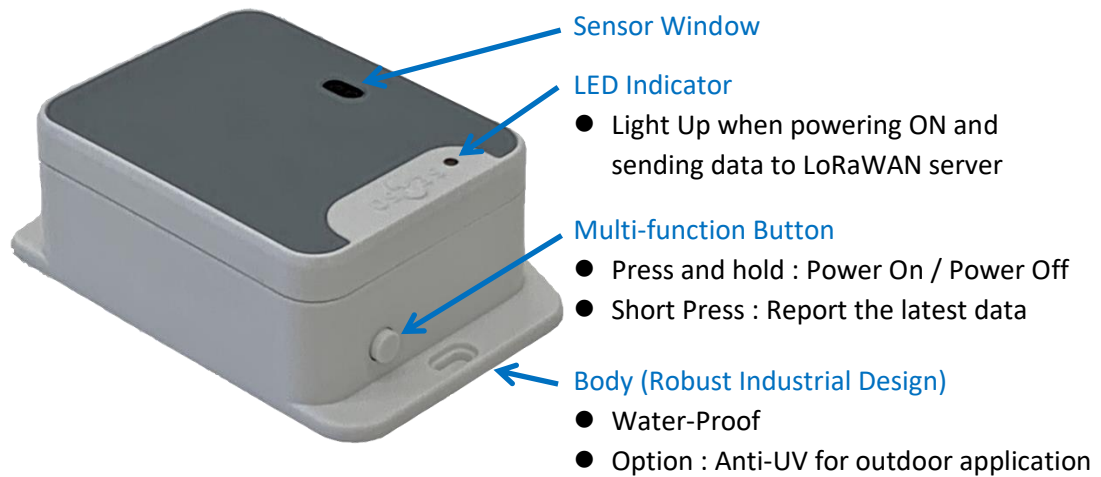

The LRS20LDO distance sensor provides a simple and efficient solution for measuring the distance of an object in front of the sensor. It can check out whether any obstacle is present or not.

Sensor Setup

1. Unfasten the screws on the corners and open the top cover.
2. Insert an ER26500 battery to the battery holder. **Make sure the polarity of the battery is correct as shown in the label on the battery holder.**
3. Make sure the CONFIG_EN jumper (JP1) is not shorted.

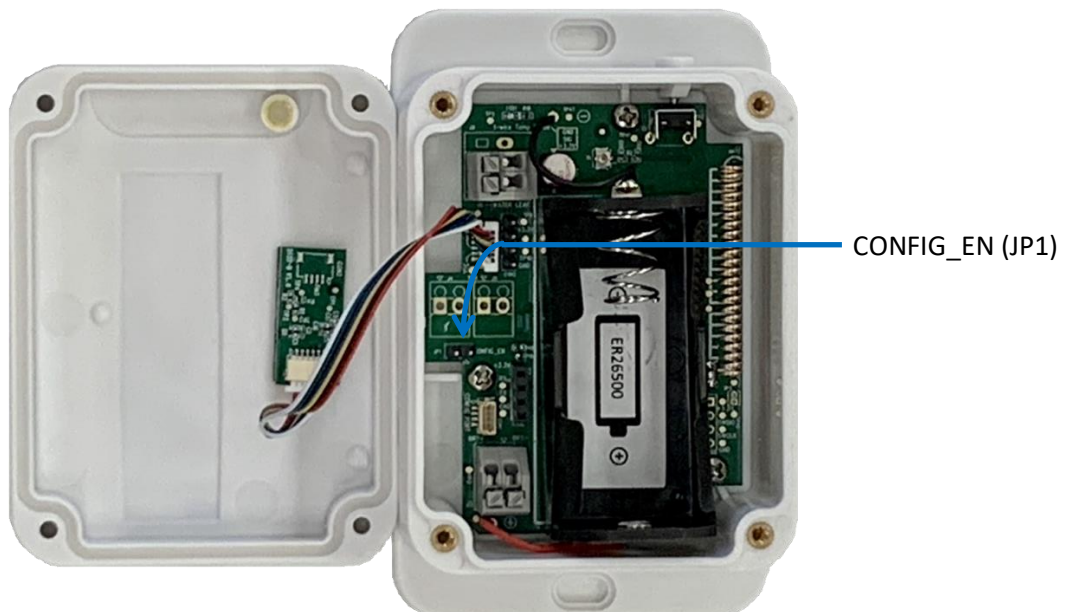

4. Put on the top cover and tighten the screws at the corners.

5. Press and hold the multi-function button until the LED indicator on the top cover lights up. (Remark: If it is configured for the OTAA activation mode and it cannot join the LoRaWAN network in 3 minutes, the LED indicator will be flashed for 2 minutes.)
6. After powering up, the sensor will send a sensor data message to the LoRaWAN network server. About the detail of the reports, please refer to “SENSO8 LoRaWAN Sensor Data Payload Format Document”.

Installation and Connection

The Distance Sensor can be mounted on any location that the sensor window pointing to an area for monitoring “Occupied” (State 1) or “Vacant” (State 0). The maximum monitoring distance between the sensor and the area is 4000 mm (or 4 meters).



To avoid the occupancy state changes repeatedly when an object is hovering near the threshold distance, two parameters (DELTA_POS, and DELTA_NEG) can be set to provide a hysteresis mechanism as illustrated in the figure below.

State toggles from "0" to "1" when $\text{Distance} < (\text{DISTTH} - \text{DELTA_NEG})$
 State toggles from "1" to "0" when $\text{Distance} > (\text{DISTTH} + \text{DELTA_POS})$

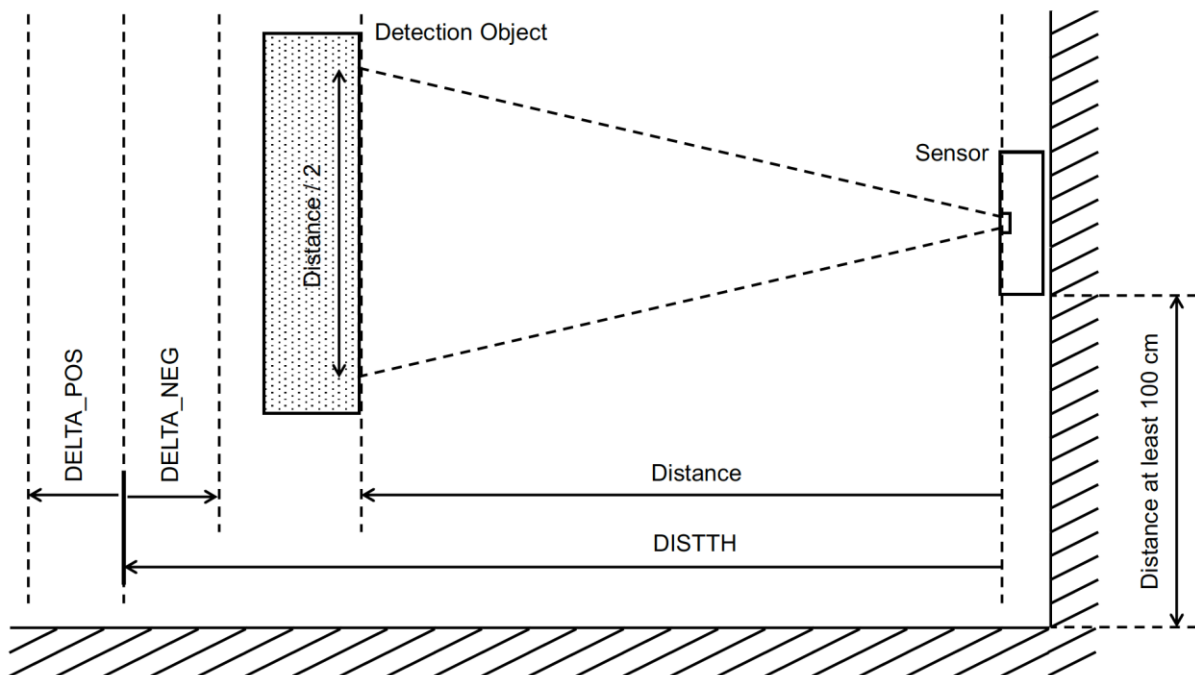

To ensure a good radio reception, install the sensor at a distance of at least 100 cm above the floor or from the wall. In addition, do not install the sensor near any metal object.

Operating Instruction

Power On

- Press and hold the multi-function button until the LED indicator turns on.
- The sensor will send a sensor data report to the LoRaWAN network server.

Power Off

- Press and hold the multi-function button for 5 seconds. The LED indicator will flash 3 times indicating the sensor has been shut down.

Report Latest Data

- Press the multi-function button briefly, the LED indicator will flash once. The sensor will send a data report to the LoRaWAN network server.
- The sensor will listen to any downlink command queued up on the LoRaWAN network server after sending the data. After receiving the downlink command, the sensor will send a response for the command.
- The sensor also sends data periodically according to the heartbeat setting.

LED Indicator

Device Status

Event	LED Pattern	Description
Powered Up	LED is turned on for a while	Device Powered Up
Report Latest Data	Single LED flash	The sensor will upload the sensor data report when the multi-function button is pressed.
Powered Down	LED flashes 3 times	Device Powered Off when the multi-function is pressed and hold for 5 seconds.

Error Status

If it is configured for the OTAA activation mode and it cannot join the LoRaWAN network in 3 minutes during powering up, the LED indicator will be flashed for 2 minutes.

Sensor Operation

The sensor performs a distance measurement periodically ("Sampling Time" is a factory setting from 1.5 to 60 seconds) in background. Any stage change (either "from 0 to 1 for Distance < DISTTH - DELTA_NEG" or "from 1 to 0 for Distance > DISTH + DELTA_POS") will trigger an interrupt from the sensor that will send a data report (Alert Report) immediately with the measured distance (DIST) and the Distance State Alert bit set in the EVT field.

The sensor always sends a data report (Heartbeat) if the data Upload Interval is reached. If it is idle (neither reading distance nor sending report), it is operated in the Sleep Mode.

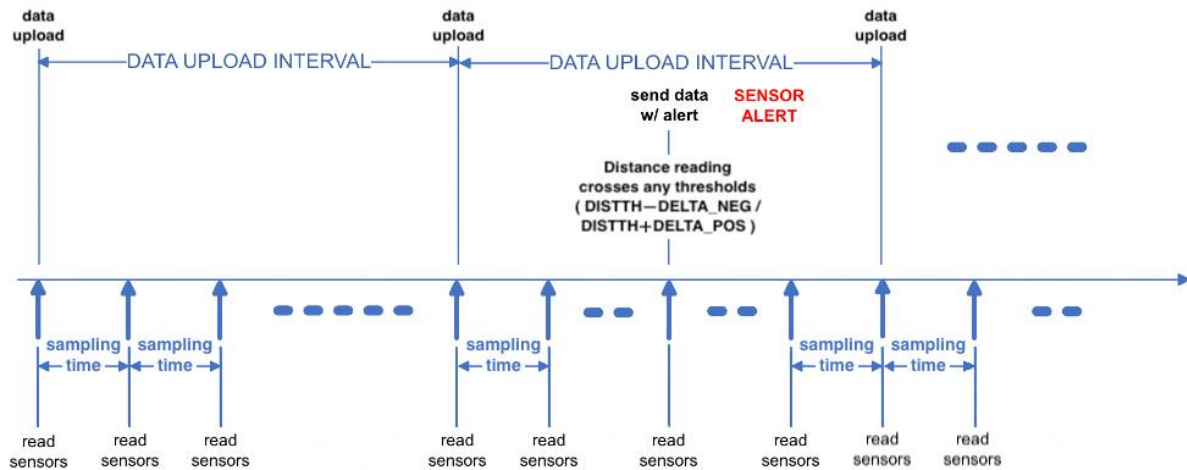

Configurable Sensor Settings

The following sensor settings are configurable via downlink data. The details of the data payload format can be found on the SENS08 Data Payload Format document.

Setting	Default Value	Unit
---------	---------------	------

Data upload interval	10	minute
Distance threshold (DISTTH)	100	mm
Distance Negative delta (DELTA_NEG)	10	mm
Distance Positive delta (DELTA_POS)	0	mm

Troubleshooting Guide

Symptom	Fix
The LoRaWAN network server cannot receive data from the sensor.	Check the configuration (activation mode, frequency plan, device info and all security keys) on the LoRaWAN server and the sensor. If there is any mis-match, the data cannot be sent to the LoRaWAN network server.
The sensor cannot be configured via download command.	Check the downlink command is sent as CONFIRMED downlink message.
The alert is not cleared when the reading is returned to the normal level.	For each alert, there is a hysteresis (DELTA_NEG and DELTA_POS) used to prevent the alert from triggering repetitively when the reading fluctuates around the threshold (DISTTH). <i>Example:</i> For [DISTTH, DELTA_NEG, DELTA_POS] is [100, 10, 0], it will trigger a state change to "1" when distance reading is less than 90. The state will return to "0" when the reading is larger than 100.

Revision History

Revision	Description	Date
1.0	Initial Release	Oct 2022