

- AGRICULTURE
- AIRPORTS
- HYDROLOGY
- INDUSTRIAL & PLC
- INTRINSICALLY SAFE
- IOT
- METEOROLOGY
- OCEANOGRAPHY
- ROAD MANAGEMENT
- POLAR AND WINTER
- SKI LIFT & SNOW MAKING
- SMART CITIES



Wind speed & wind direction

Compact anemometer and wind direction vane sensor with ultra-low power, lightning protection & no dead spot.

Meets all WMO measurement standards.

Designed for wireless AWOS, IoT LoRaWAN, IoT Sigfox and NB-IoT weather stations. Elliptical cup design offers superb aerodynamics in a compact and cost-effective package of anodized aluminum suitable for most environments.

Superb dirt and weather resistance for **long-term wind measurement stability & reliability** in all environments.

Compact analog design with high dirt resistance

- Robust dendriform dual-arm reinforced cup design
- Replaceable cups for quick and easy service with standard tools
- Faster response than ultrasonic wind sensors & higher data availability
- Flat elliptical cup shape offers superb snow shedding and very good hail resistance
- All-metal anodized-aluminum body and wind vane

Ultra-low power for wireless applications

- Ultra-low power electronics offer industry's lowest combined power consumption of less than 50 μ A for wind speed and wind direction combined
- ESD, EMC & lightning resistant reed switch wind speed sensor with two pulses per revolution
- ESD, EMC & lightning protected magnetic wind vane sensor with better than 5° accuracy and 0...2.5 V analog output.
- Wide voltage range from 3.2 V to 15 V
- Suitable for all wired and wireless installations
- Patented design of flat elliptic cups for superb winter snow shedding even without heating
- High linearity and accuracy with < 1 m distance constant

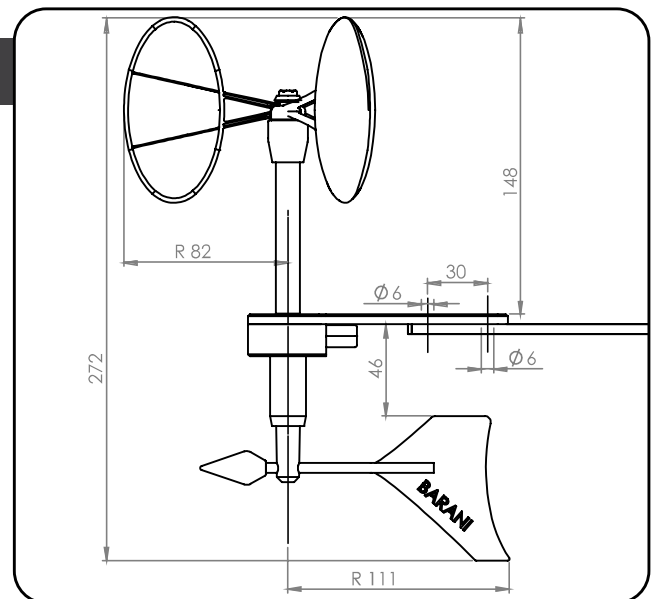

A direct more reliable and accurate replacement for ultrasonic anemometers

Measurement standards				
	Range	Resolution	Accuracy	Sampling rate
Wind speed	0-85 m/s gust	0.01 m/s	1% or ±0.2 m/s (the greater of) or ±0.05 m/s (4-16 m/s) with MEASNET calib	2 pulses per revolution
Wind direction	0-360°	1°	2° (no dead-spot)	10 Hz /1Hz avg. out
Linearity	R ² > 0.99995			
Tilt angle sensitivity	Cosine response, see graph. (Horizontal wind speed measurement)			
Starting wind speed	<0.2 m/s			
Default linearity constants (Calibration equation coefficients)	Anemometer Cups before 2023: $m/s = 0.6335*(Hz) + 0.3582$ Dendriform Cups 2023+: $m/s = 0.6480 * (Hz) + 0.3950$ for ±1% (0-38 m/s) or quadratic linearization: $m/s = -0.00065 * (Hz)^2 + 0.6750*(Hz) + 0.2000$ for ±0.2 m/s			
Distance constant (Delay distance)	Wind speed: < 1.3 m (est.) (per ASTM D 5096-96), Wind direction: < 0.5 m (damping ratio = 0.2)			
Electrical specifications				
Output signal & communication	Wind speed: Pulse output, switched GND, (24 Ω reed switch). Recommended current & voltage for long life < 0.5 mA & ≤ 2.5 V. Max allowed 10 mA & 15 V. Wind direction: Analog 0...2.5 VDC			
Supply voltage	3.2 V...15 VDC reverse polarity protection			
Power consumption	50 µA (combined wind speed and wind direction)			
Lightning & surge protection	per IEC EN 61000-4-5 on wind vane & power lines, Surge, EFT/Burst, ESD 15kV			
Environmental ratings				
Operating temperature & humidity	-40 °C to + 80 °C, 0 % to 100 % RH			
Survival wind speed	>85 m/s (306 kph, 190 mph) gust			
IP – Protection rating	IP65W (DIN 40050)			
General specifications				
Heater (optional)	4W non-regulated @ 12 Vdc or VAC, (Max continuous 12W in temperatures < 20 °C) Heater requires an external power supply and regulator.			
Weight (mass)	Anemometer = 210 g			
Dimensions	Anemometer rotor diameter = Ø164 mm, Wind vane radius = 111 mm, Total height = 272 mm			
Patented / Registered	OHIM 002153882-0001, 002153882-0002, 002153882-0003			
Mounting	Two M6 screws with nuts (includes a 90° stainless steel mounting arm)			

Advantages of a compact anemometer & wind vane design

Simple construction and simple electronics with integrated lightning protection offer improved levels of reliability. Compact anemometer body size increases anemometer accuracy and reduces winter snow buildup for improved winter operations.

Other customer related benefits from this combined wind sensor include:

- Reduction in the number of components and sensor mounting structure
- Less wiring for simpler installation and better weather & lightning resistance
- Reduction on-site installation and service time due to reduces AWOS complexity

Wiring and connection per cable identification to DIN 47100				
Number	Color	Short form	Anemometer Function	Description
1	white	WH	GND	GND - Isolated from metal body
2	brown	BN	Vcc	3.2 -15 V
3	green	GN	Wind speed	Reed switch with 2 pulses per revolution
4	yellow	YE	Direction	0-2.5 V corresponding with 0-360 degrees
5	gray	GY	Heater	Heater (non-regulated)
6	pink	PK	Heater	Heater (non-regulated)

Reach your gold standard of measurement with BARANI DESIGN ISO:9001 quality.