

OPTION

Spot-On

NB-IoT

PARKING SENSOR SPS100



- Parking sensor ideal for Smart City applications in combination with actuators such as Smart Public Lighting and EV-charging stations.
- On-surface parking sensor detects the presence of vehicles above the sensor.
- Magnetic sensor and 60 GHz radar sensor assure reliable operation with long battery autonomy up to 5 years.
- Low power NB-IoT communication to data back-end.
- Open API enabling Cloud Platform access.
- Over-the-air configuration.
- Integrated NFC connectivity enabling local control and configuration.
- High-precision geomagnetic sensors, greater than 99%.

OPTION

Operation

After mounting, the parking sensor is activated via NFC technology. Its built-in magnetic sensor will continuously monitor changes in the magnetic field caused by the movement of vehicles.

The parking sensor's built-in radar sensor will then confirm when a vehicle is positioned above the sensor.

This algorithm ensures optimal use of the battery while maintaining high accuracy. The battery level is periodically monitored and sent to the back-end server at a configurable interval.

The radar and magnetic detection enable operation under extreme weather conditions including sensor obstruction e.g. leaves, snow,...

Use case scenarios

- Detect when parking spots for electric vehicle charging are used by vehicles that are not using the EV charging infrastructure.
- Guide vehicles to the available parking spaces.
- Monitor the occupation of short-term parking spaces to detect parking violations.

Dimensions

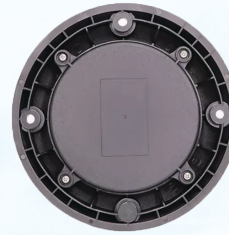
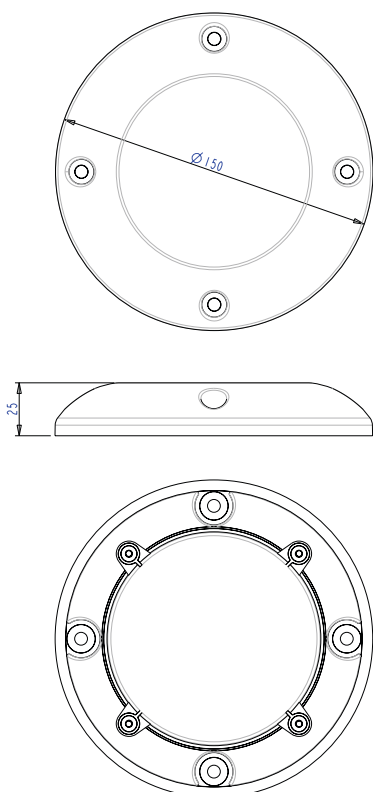

2 independent sensor principles

Technical Specifications		
Physical information	Dimension	150 mm diameter x 25 mm
	Colour	Black
	Mounting	4 mounting holes
	Material	Nylon
	Weight	300 g
	Max load	5 - 10 tonnes
	Impact Protection Rating	IK7
Electrical information	Battery	Triple-pack AA size (LiSOCl ₂ , 3.6V, 8100 mAh)
	Autonomy	Minimum 3 years when <ul style="list-style-type: none"> • Max 50 in/out movements per day • Good NB-IoT signal conditions (MCS6/SC1/CE level 0) 5 years when <ul style="list-style-type: none"> • Max 30 in/out movements per day • Good NB-IoT signal conditions
Technology information	Cellular modem	NB-IoT <ul style="list-style-type: none"> • EU bands: B3/B8/B20 • International coverage (on demand) • B1/B2/B3/B4/B5/B8/B12/B13/B17/B18/B19/B20/B25/B28/B66/B70/B85 • Integrated PCB antenna
	Magnetic sensor	Earth magnetic field (high-accuracy, 3-axis digital output magnetometer)
	Pulsed Coherent Radar	<ul style="list-style-type: none"> • 60 GHz • Detection distance between 30 - 600 mm
	Integrated NFC tag	ISO/IEC 15693
Environmental information	Operating temperature	-20°C to 60°C
	Humidity	5% to 95% relative humidity (non-condensing)
	IP class	IP67
	Usable altitude	Minimum: -100 m Maximum: 3000 m
Certification	CE Radio Equipment Directive (RED) 2014/53/EU, RoHS/REACH, WEEE	

Product	PN
Spot-On SPS100	SE0203-12239

DISCLAIMER

All product specifications are subject to change without notice.