

Supercal 739

Compact Thermal Energy Meter

Single jet



Coaxial Multi-Jet Meter with G 2" thread



Coaxial Multi-Jet Meter with M77x1.5 thread



Coaxial Multi-Jet Meter with M62x2 thread



Application

The **Supercal 739** is an autonomous compact thermal energy meter consisting of a flow meter, a detachable integrator with a wide range of communications options and a pair of temperature sensors. It's used in home automation, local and district heating/cooling systems to measure the consumption of heating or/and cooling energy for individual billing.

The **Supercal 739** is available in various models, measures the temperature within the range of 0°C to 110°C and meets the requirements of the European Measuring Instruments Directive (MID) 2014/32/EU and the standard EN 1434 class 3.

Standard features

- Configured as a heat meter MID with temperature sensors $\varnothing 5$, $\varnothing 5.2$ or $\varnothing 6$ mm with 1.5m cable.
- Optical interface for readout and 6+1 years battery life time
- Easy to operate and read
- Non-volatile EEPROM memory, that keeps stored data even in case of power failure
- 18 monthly energy values for heat energy and volume
- Self-monitoring and error display

Model

The **Supercal 739** is available in the following model:

- Mechanical flow meter for flows q_p 0.6 m³/h, q_p 1.5 m³/h, q_p 2.5 m³/h with
 - Single jet flow sensor
 - Coaxial multi jet flow sensor with G2" or a M77x1,5 thread
 - Coaxial multi jet flow sensor with M62x2 thread for flows q_p 1.5 and q_p 2.5 m³/h

Size

The **Supercal 739** single jet is available in the following sizes:

- Flow meter for q_p 0.6 m³/h, with a length of either 110 mm
- Flow meter for q_p 1.5 m³/h, with a length of either 110 mm or 130 mm
- Flow meter for q_p 2.5 m³/h, with a length of either 110 mm or 130 mm

Options

The Supercal 739 can be ordered with following options

- Ø 5,2 mm or Ø 6 mm temperature sensors
- 12+1 years battery
- One of the following communications options:
 - Self-powered M-Bus
 - Bidirectional Radio SONTEx interface
 - Wireless M-Bus
 - LoRaWAN
 - Two pulse outputs either heating or cooling energy consumption and volume, or heating and cooling energy consumption
- Two additional pulse inputs

Functions

- Measure and record energy consumption and volume of the flow in heat or cooling applications
- Optionally measure and record the second “energy consumption”, for heat/cooling applications
- If the two additional inputs were configured then record the provided values. The configuration can be done either through the optical interface, via M-Bus or by radio SONTEx.
- Display of consumption data depending on configuration:
 - 18 monthly energy heat, volume and, if configured, energy Tariff 1 (cooling energy)
 - 18 monthly values of additional pulse input 1 and 2 respectively
 - Set day values
- Display operating data including self-monitoring with error display

Temperature sensors

The pair of temperature sensors Pt 1'000 is connected to the integrator and is an integral part of the heat meter. The sensor with a colourless marking is mounted and sealed directly into the flow sensor. The temperature sensor with the orange marking must be mounted in the pipe “opposite” to the **Supercal 739**.

The temperature sensors mustn't be changed or modified.

Integrator

The integrator is equipped with a large 8-digits display and can be rotated by 360°. The integrator can be separated from the flow sensor and be installed separately. A cable of 0,6 meter connects the integrator to the flow sensor.

The housing has a protection index of IP65 against dust and humidity.

Display

The LCD display of the **Supercal 739** has a large, clear design and high contrast, making it easy to read the data.

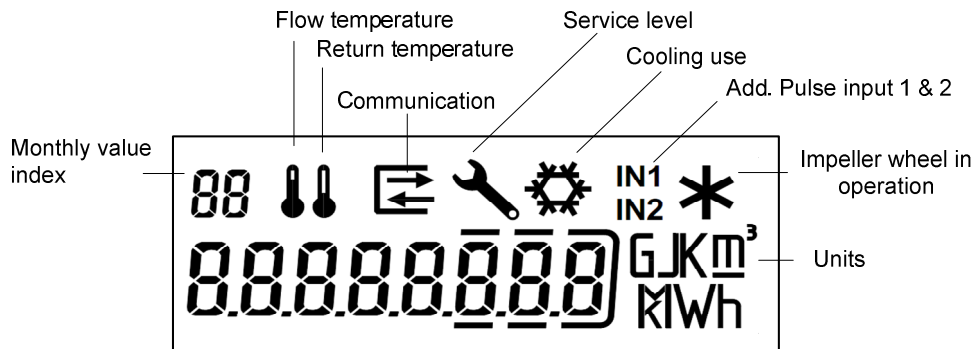

Display sequences

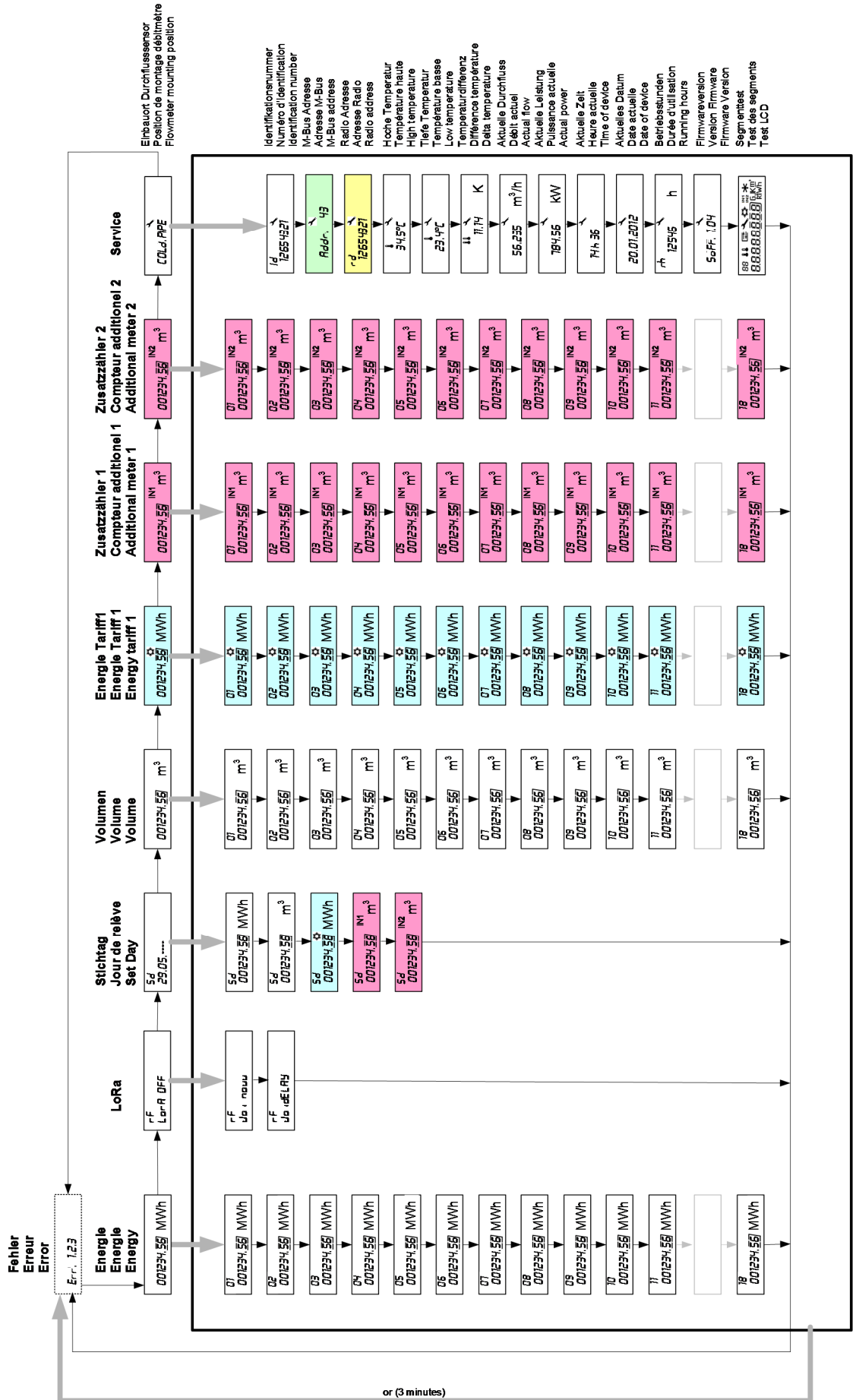

Error messages

Err 1	Flow higher than 1.2 x q _s or faulty flow sensor.
Err 2	Measured temperature out of range or faulty temperature sensor.

Measuring principle

The medium flowing through the system drives the impeller wheel and the rotational speed is scanned electronically using a magnet (single jet) or inductive (coaxial multiple jet) principle detection. The temperature difference in the supply and return line is measured with a pair of platinum temperature sensors (Pt 1'000).

Energy calculation

The flow sensor records the flow. The thermal energy consumption, respectively the heating and cooling energy are calculated by means of the temperature difference between hot and cold pipe, the recorded volume, and the heat coefficient. The latter takes into consideration the density, the viscosity and the specific heat of the liquid used. All these are dynamically adapted in function of the temperature.

Cooling energy

The cooling energy in combined heat/cooling applications is stored in another memory than the heat energy and will be cumulated only if the two following conditions are fulfilled:

- Temperature difference(Δt) > -0.5K
- Supply temperature < 18°C

The cooling energy has the same physical unit as the heat energy. The cooling power and the temperature difference are in this case displayed with a minus sign (-). If required it is possible to order the **Supercal 739** with another threshold than the 18°C.

Non-volatile memory

The device parameters, as well as the cumulative values for energy and volume, cooling energy, monthly values, set day values, values of the pulse input counters 1 and 2, operating hours and error type are stored in a non-volatile memory (EEPROM), where they are saved even in case of a power failure (e.g. changing batteries). Once an hour and in the event of battery failure, the cumulative values are updated in the EEPROM.

Monthly values

At the end of each month, the monthly values are stored. Depending on the configuration a total of 18 monthly values of heat energy, volume, cooling energy and of the additional pulses inputs 1 and 2 are memorized in the integrator.

Pulse inputs

As an option the **Supercal 739** offers the possibility to integrate two additional pulse inputs such as from a hot water and a cold water meter.

Communication options

Several communication interfaces are available.

The configuration of the selected communication option of the **Supercal 739** can be carried out with the free software Prog7x9 from Sontex.

TECHNICAL DATA SUPERCAL 739

Temperature sensors

2 wire temperature sensor	Pt1'000
Diameter	Ø5.0; Ø5.2, Ø6.0 mm
Cables length	1.5 m

Measurement

Approved temperature range θ	0...110°C
Approved for long term operating temperature θ_q	5...90°C
Differential range $\Delta\theta$	3...75 K
Response limit	0.5 K
Temperature resolution t (display)	0.1 °C
Temperature resolution Δt (display)	0.01 K
Temperature-measurement cycle at nominal flow	10 seconds

Integrator General

Environment class	C
Mechanics	M1
Electronics	E1
Battery protection class	III
Cable connection between flow sensor and integrator	0.6 m, fix
Integrator Protection index	IP 65
Operating temperature	5...55°C
Operating temperature with radio option	5...40°C
Storage and transport temperature	-10...60°C

Display & Display units

LCD with 8-digits	
Energy	kWh, MWh, GJ
Volume	m ³
Additional pulse inputs	Volume or pulses
Temperature	°C
Δ Temperature	K

Power supply

Lithium Metal Battery ($\leq 1g$) 3VDC	6+1 or 12+1 years
--	-------------------

Powered by M-Bus line

1 device = 2 M-Bus charges (max 2 x 1.5mA)

Pulse output

Open drain (MOS Transistor)	1 Hz, 500 ms
$V_{CC_{max}}$: 35 V _{DC} ; $I_{CC_{max}}$: 25 mA	

Pulse inputs with a dry contact

Power supply <small>internal</small>	2.3 V _{DC}
$R_{pull\ UP\ internal}$	2 M Ω
Pulse factor	0...999.999 m ³ /Imp or without unit

Single Jet Flow Sensor

qp	Threaded connection		Mounting length	Mat.	PN	Maximal flow qs	Minimal flow qi	Low flow threshold value (50°C)	Threaded hole for sensor	Total Meter Weight	Kvs value (20°C)	Pressure loss at qp
	G"	DN										
	(EN ISO 228-1)						*(h / v)					
0.6	3/4"	(15)	110	Br	16	1,2	12 / 24	3	Yes	0.8	1.3	0.22
1.5	3/4"	(15)	110	Br	16	3,0	30 / 60	3	Yes	0.9	3.2	0.22
1.5	1"	(20)	130	Br	16	3,0	30 / 60	3	Yes	1.0	3.2	0.22
2.5	1"	(20)	130	Br	16	5,0	50 / 100	8	Yes	1.1	5.1	0.24

*(h / v): Horizontal mounting / vertical mounting; Br: brass
16 bar = 1.6 MPa

Pressure loss curve

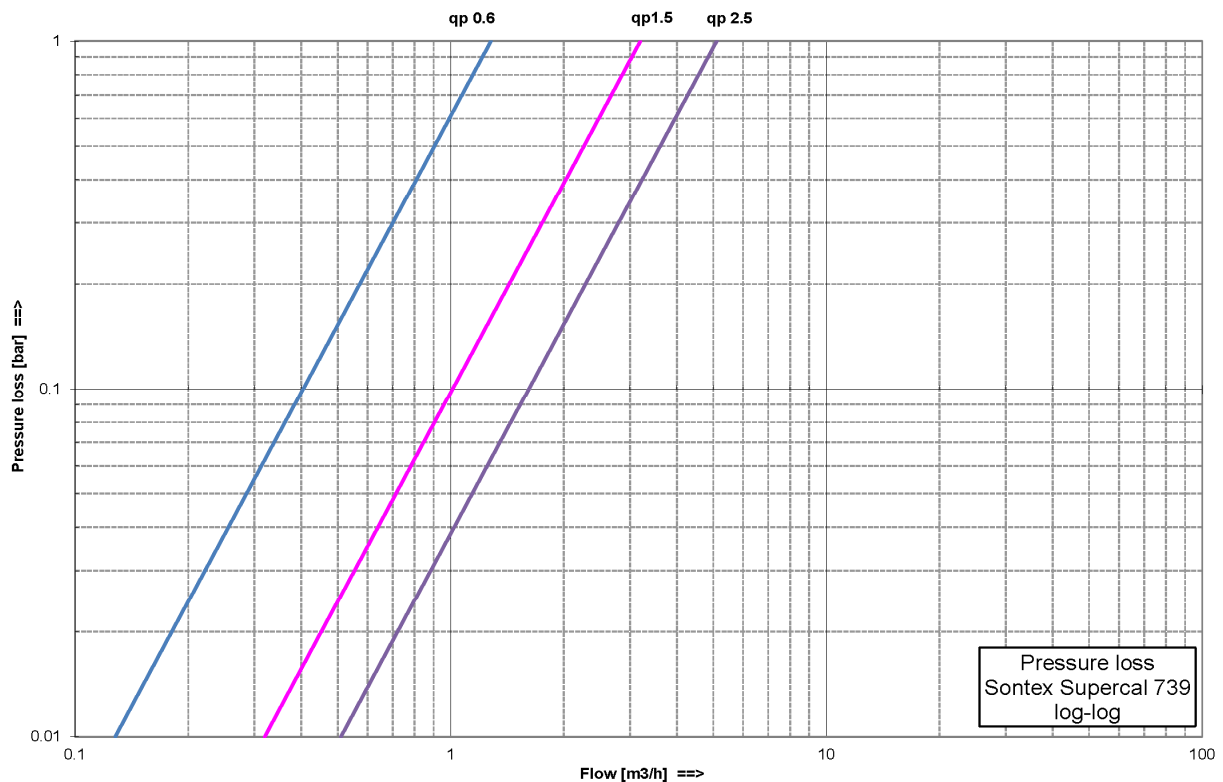

Metrological class

EN 1434 class 3

Mounting

The Supercal 739 should not be mounted on the side where the continuous operating temperature of the liquid exceeds 90°C or is below 5°C.

Length of straight section fitted upstream/downstream of each flow meter (EN1434):
U3 / D0 for: L=110mm and L=130mm

Dimensions

Dimensions integrator	110.2 mm x 87.1 mm
Total Height	91.7 mm
Height from the axis of the tube	74.4 mm
Height without integrator	38.9 mm

Supercal 739, single jet
(L: 110 mm)

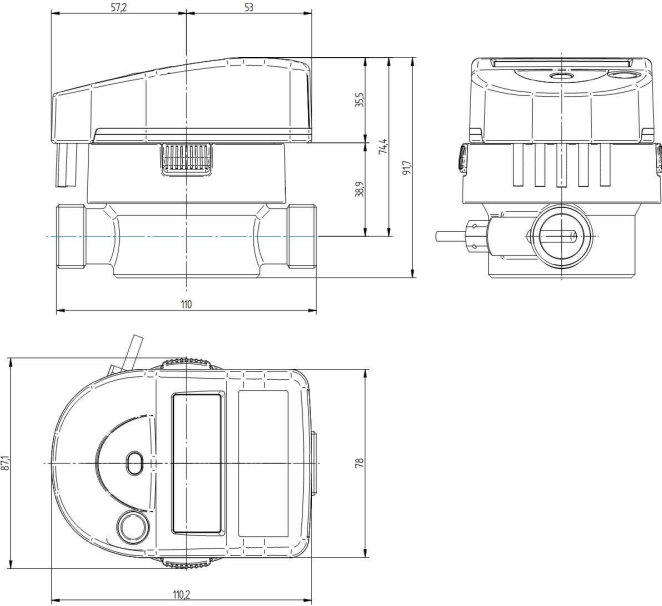

Coaxial Multiple Jet Flow Sensor with G2" connection

qp	Threaded connection *EAS		Mounting length mm	Mat.	PN	Maximal flow qs m ³ /h	Minimal flow qi l/h	Low flow threshold value (50°C) l/h	Threaded hole for sensor	Total Meter Weight kg	Kvs value (20°C) m ³ /h	Pressure loss at qp bar
	G"	DN										
	(EN ISO 228-1)											
0.6	3/4"	(15)	110	Br	16	1,2	12	8	Yes	0.6	1.7	0.08
1.5	3/4"	(15)	110	Br	16	3,0	15	10	Yes	0.6	3.4	0.19
1.5	1"	(20)	130	Br	16	3,0	15	10	Yes	0.6	3.4	0.19
2.5	1"	(20)	130	Br	16	5,0	25	17	Yes	0.7	5.9	0.18

*EAS: base;

Br: brass

16 bar = 1.6 MPa

Pressure loss curve

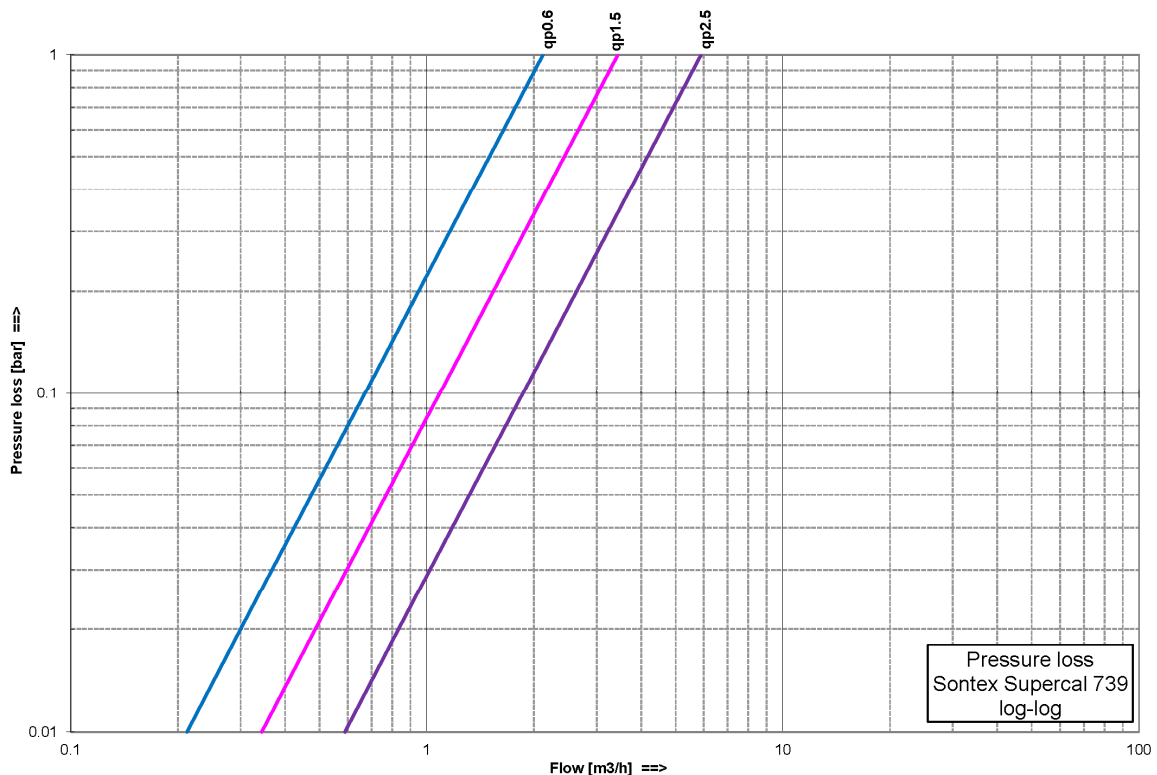

Metrological class

EN 1434 class 3

Mounting

External thread of the coaxial part G2"
 The Supercal 739 should not be mounted on the side where the continuous operating temperature of the liquid exceeds 90°C or is below 5°C.
 Length of straight section fitted upstream/downstream of each flow meter (EN1434):
 U0 / D0 for: L=110mm and L=130mm

Dimensions

Dimensions integrator	110.2 mm x 87.1 mm
Total height	90.6 mm
Height from the base	77.7 mm
Height without integrator	42.2 mm

Supercal 739, Coaxial Multiple Jet Flow Sensor with G2" connection

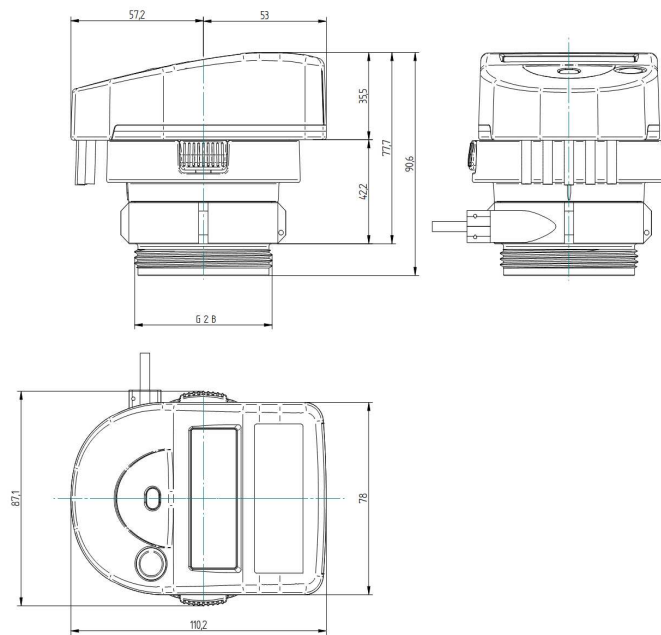

Coaxial Multiple Jet Flow Sensor with M77x1.5 connection

qp	Threaded connection *EAS		Mounting length mm	Mat.	PN bar	Maximal flow qs m ³ /h	Minimal flow qi l/h	Low flow threshold value (50°C) l/h	Threaded hole for sensor	Total Meter Weight kg	Kvs value (20°C) m ³ /h	Pressure loss at qp bar
	G"	DN										
	(EN ISO 228-1)											
0.6	3/4"	(15)	110	Br	16	1,2	12	8	Yes	0.8	1.7	0.08
1.5	3/4"	(15)	110	Br	16	3,0	15	10	Yes	0.8	3.4	0.19
1.5	1"	(20)	130	Br	16	3,0	15	10	Yes	0.8	3.4	0.19
2.5	1"	(20)	130	Br	16	5,0	25	17	Yes	0.9	5.2	0.23

*EAS: base;

Br: brass

16 bar = 1.6 MPa

Pressure loss curve

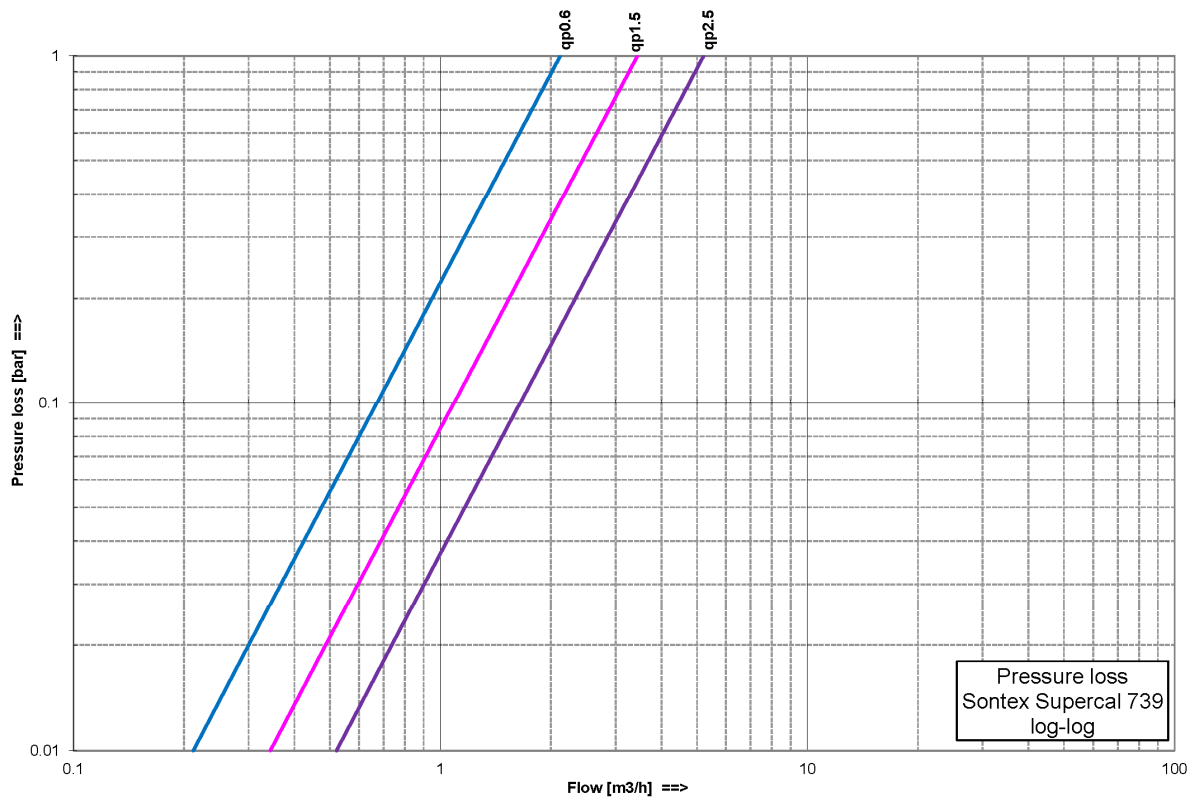

Metrological class

EN 1434 class 3

Mounting

External thread of the coaxial part

M77x1.5

The Supercal 739 should not be mounted on the side where the continuous operating temperature of the liquid exceeds 90°C or is below 5°C.

Length of straight section fitted upstream/downstream of each flow meter (EN1434):
U0 / D0 for: L=110mm and L=130mm

Dimensions

Dimensions integrator

110.2 mm x 87.1 mm

Total height

120.1 mm

Height from the middle of the base

106.1 mm

Height without integrator

70.6 mm

Supercal 739, Coaxial Multiple Jet Flow Sensor with M77x1.5 connection

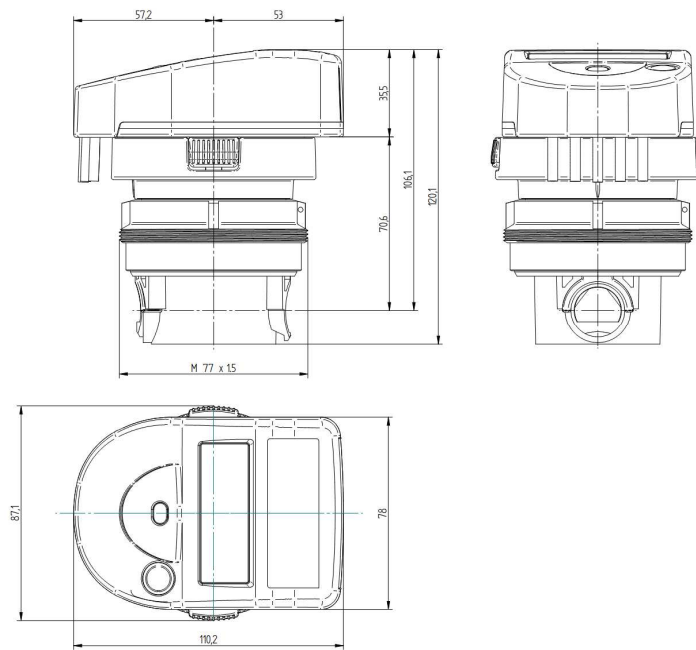

Coaxial Multiple Jet Flow Sensor with M62 x 2 connection

qp	Threaded connection *EAS		Mounting length	Mat.	PN	Maximal flow qs	Minimal flow qi	Low flow threshold value (50°C)	Threaded hole for sensor	Total Meter Weight	Kvs value (20°C)	Pressure loss at qp
	G"	DN										
	(EN ISO 228-1)											
1.5	3/4"	(15)	110	Me	16	3,0	30	10	Ja	0.7	3.4	0.20
1.5	1"	(20)	130	Me	16	3,0	30	10	Ja	0.7	3.4	0.20
2.5	1"	(20)	130	Me	16	5,0	50	15	Ja	0.7	5.7	0.19

*EAS: base;

Br: brass

16 bar = 1.6 MPa

Pressure loss curve

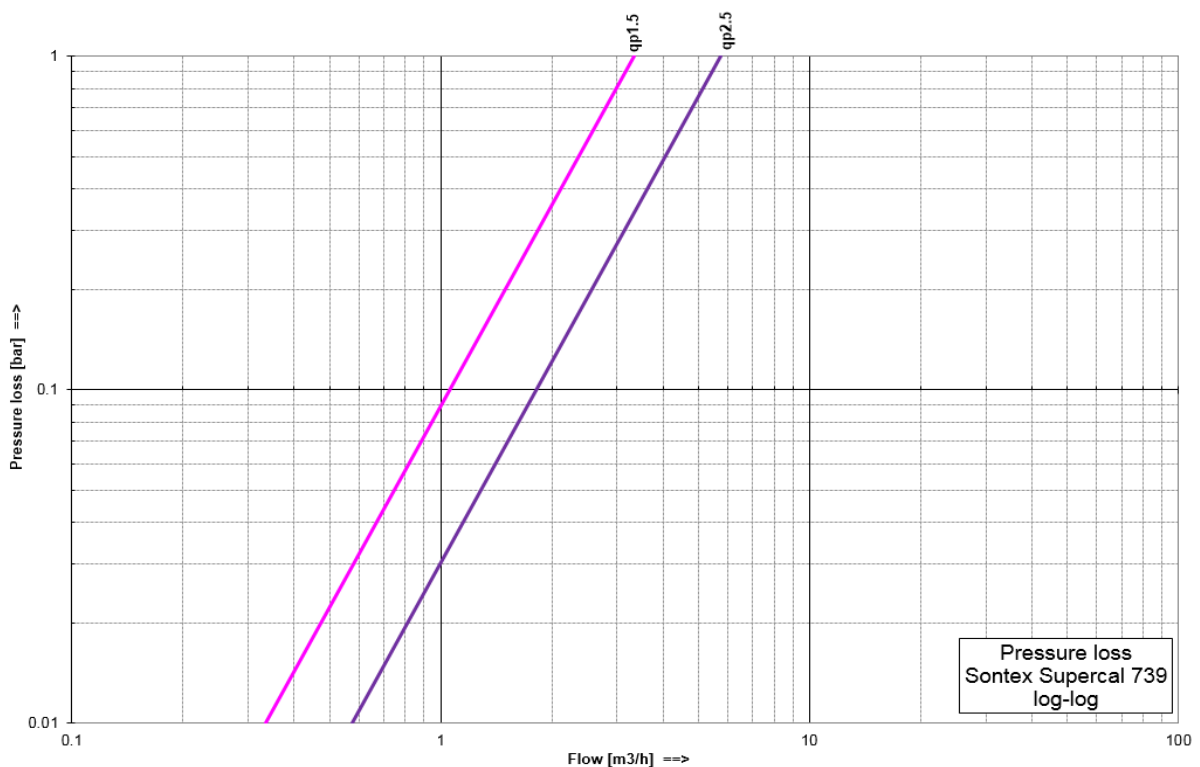

Metrological class

EN 1434 class 3

Mounting

External thread of the coaxial part

M62x2

The Supercal 739 should not be mounted on the side where the continuous operating temperature of the liquid exceeds 90°C or is below 5°C.

Length of straight section fitted upstream/downstream of each flow meter (EN1434):

U0 / D0 for: L=110mm and L=130mm

Dimension

Dimensions integrator

110.2 mm x 86.8 mm

Total height

105.6 mm

Height from the middle of the base

90.6 mm

Height without integrator

45.0 mm

Supercal 739, Coaxial Multiple Jet Flow Sensor with M62x2 connection

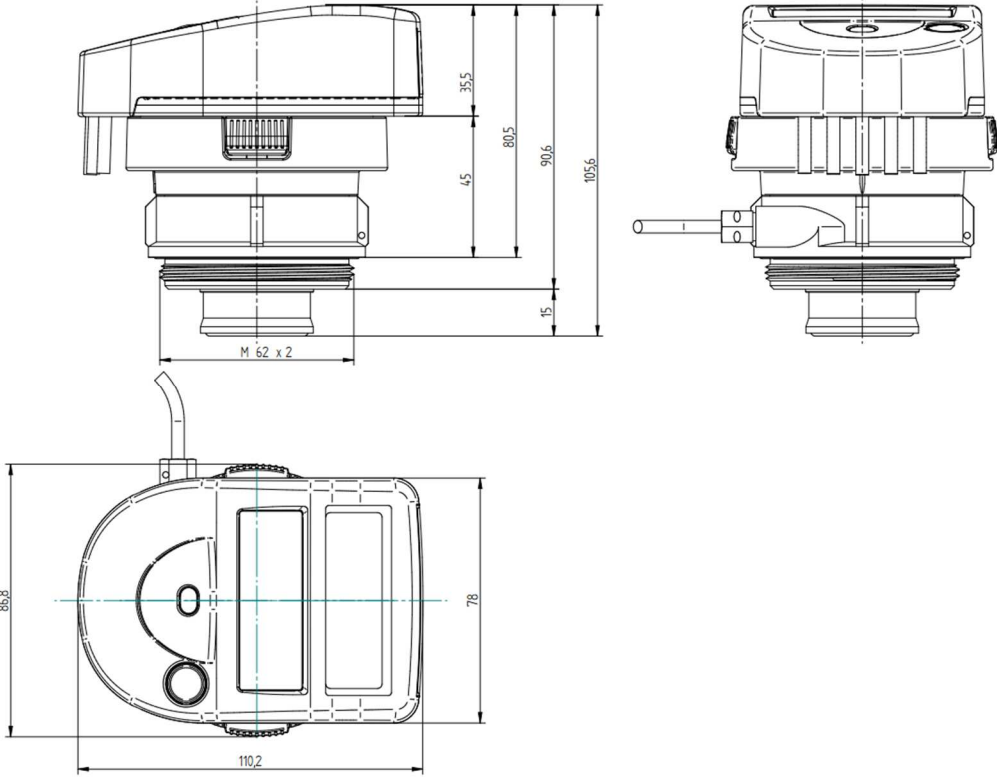



Technical support

For technical support, please contact your local Sontex representation or Sontex SA directly.

Hotline Sontex: sontex@sontex.ch +41 32 488 30 04

CE conformity according to

Directive 2014/32/EU (MID)

RED 2014/53/EU

Detailed declarations of conformity can be found on our homepage:

www.sontex.ch

Modifications subject to change without notice

DS_Supercal 739_V02_2007_en

© Sontex SA 2020