

# Atomsenses LoRaWAN Gateway

## Product Specification

### Applicability

This guide applies to the following Atomsenses products, unless otherwise specified:

Model	Description
AS-GW1000	- Indoor LoRaWAN Gateway
AS-GW5000	- Outdoor LoRaWAN Gateway

### Declaration of Conformity

Atomsenses sensors and other products comply with the essential requirements and relevant provisions of FCC, CE/EMC, and RoHS standards.

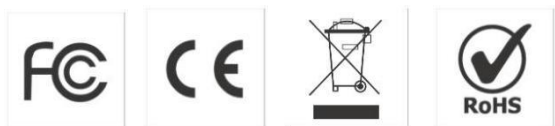

## LoRaWAN Indoor Gateway

### Hardware Introduction

The GW1000 is an Internet of Things (IoT) gateway built on the low-power, wide-area LoRaWAN protocol. It boasts exceptional signal coverage and penetrating capabilities, offering a convenient solution for bidirectional data transmission in IoT applications. The gateway is equipped with a high-performance transceiver chip from Semtech, capable of simultaneously receiving signals from up to 8 LoRa wireless channels. It can transparently transmit wireless data to an external LoRaWAN Network Server (NS) via Ethernet or 4G, or be configured to use an embedded NS for direct integration with customer application platforms.

The GW1000 is widely applicable in various scenarios such as communities and industrial parks, providing a secure and stable LoRa network service for network coverage.

### Features

- Supports standard LoRaWAN protocol V1.0.X (V1.0.2, 1.0.3, 1.0.4), V1.1;
- Supports device types Class A and Class C;
- 8 uplinks channel, 1 downlink channel;
- Supports UDP packet\_forwarder protocol, Basics Station CUPS, and LNS protocol;
- Can switch between embedded NS or external NS server as needed;
- Embedded NS supports MQTT and HTTP to push and parse data, and Ethernet Modbus-TCP to query node data;
- Embedded NS MQTT protocol supports data transmission to the platform for nodes even when the network is disconnected;
- Supports WiFi connection to the gateway for viewing gateway status, modifying gateway configuration, and viewing real-time node data;  
Supports firewall protection, SYN-flood defense, and DNS rebinding protection;
- Support remote OTA upgrade, self-diagnosis and repair;
- Support TF card log storage;
- Two external RJ45 ports, one for WAN and one for LAN;
- Supports IPV6, uses 4G for networking, and provides IPV6 public network IP addresses for LAN and WiFi;
- Supports intelligent switching between WAN and 4G interfaces, prioritizing the WAN port and automatically switching to 4G if the WAN port is abnormal;
- LTE supports three module options, including for China, Europe, and the United States Device Appearance



## Dimensions(mm)

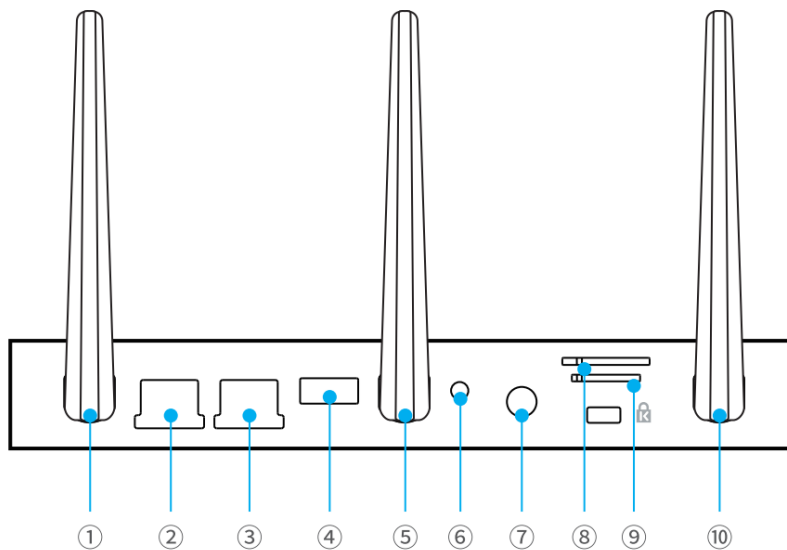
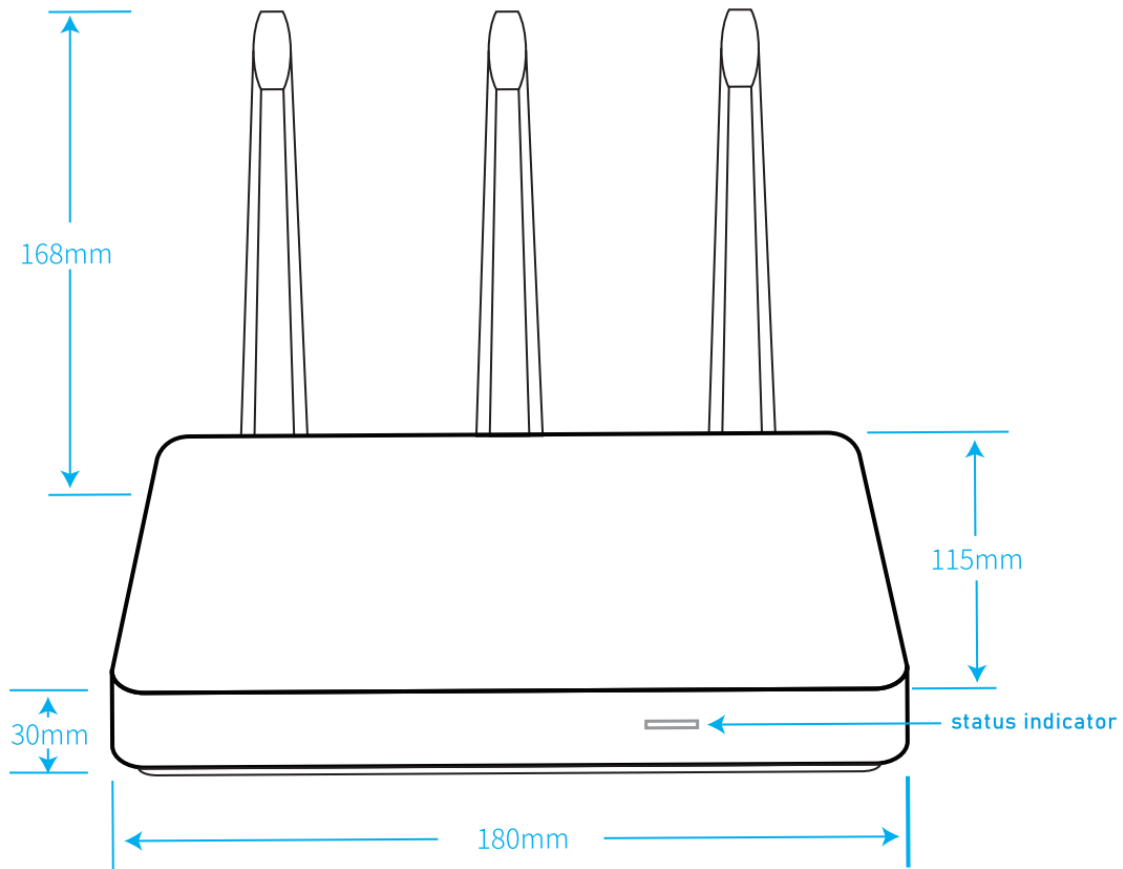

- 1.LoRa antenna
- 2.WAN and LED indicator
- 3.LAN and LED indicator
- 4.USB port
- 5.LTE antenna-Optional
- 6.Reset butoon
- 7.DC12V power supply port
- 8.SIM standard card slot
- 9.TF card slot
- 10.WiFi antenna



Led	Display	Description
Status led	Green, flash	Initializing
	Green, constant on	On normal working
	Red	Device not working
	Yellow	Network fault, cannot connect to the network server or not return ACK to device
WAN port led	Flash	Data transmits from Internet, can access to network
	Off	Can not access to network
LAN port led	Flash	Data sent to the computer. Connected
	Off	LAN port not activated

## Technical specifications and standards

Specifications	Parameters
Master control	Qualcomm 9531 master control chip, 128M memory, 16M Flash
Power supply	DC12V
LoRa frequency	CN470-510/EU863-870/US902-928/AS923/AU915-928/KR920-923 (Optional)
LoRa communication rate	292bps - 5.4kbs, support spread factor SF7-SF12
LoRa Tx power	17dBm Maximum power: 20dBm (at the antenna mouth)
LoRa Rx sensitivity	-141dBm@SF12
LoRa antenna gain	2dBi
LoRa antenna type	Omni-direction
Channel	8 uplinks, 1 downlink
LoRa working mode	Half-duplex
Base station	Network
LTE model	Europe/Korea/Thailand/India 4G modules support the following frequency bands:  FDD LTE: B1/B3/B5/B8/B20 TDD LTE: B38/B40/B41 WCDMA: B1/B5/B8 GSM: B3/B8  North America 4G module supports the following frequency bands:  FDD LTE:B2/B4/B5/B12/B13/B14/B66/B71B



	<p>WCDMA: B2/B4/B5</p> <p>Latin America/Australia/New Zealand 4G modules support the following frequency bands:</p> <p>LTE-FDD: B1/B2/B3/B4/B5/B7/B8/B28          LTE-TDD: B40          WCDMA: B1/B2/B5/B8          GSM/EDGE: B2/B3/B5/B8</p> <p>Global Band 4G module supports:</p> <p>LTE-FDD:          B1/B2/B3/B4/B5/B7/B8/B12/B13/B18/B19/B20/B25/B26/B28          LTE-TDD: B38/B39/B40/B41          WCDMA: B1/B2/B4/B5/B6/B8/B19          GSM: B2/B3/B5/B8</p>
WiFi	2.4GHz, AP mode, Maximum power: 18dBm
Data backhaul	10/100M Ethernet, 3G/4G
Debug interface	WiFi; LAN; serial port
Temperature	-10°C~50°C
Humidity	5%~95%
Power Consumption	7W
Dimension	180mm*115mm*30mm (antenna not included)

## LoRaWAN Industrial grade outdoor Gateway

### Hardware Introduction

The GW5000 is a cutting-edge Industrial-grade IoT gateway router operating on the energy-efficient LoRaWAN protocol, offering a versatile suite of wireless communication capabilities including LoRa, 2G/3G/4G, WiFi, and GPS. This gateway enables the deployment of scalable IoT control systems that deliver tailored smart services with ease.

With its star topology, the GW5000 facilitates seamless single-hop wireless communication from end devices to one or multiple gateways, ensuring reliable connectivity between terminal devices and cloud infrastructure. Alternatively, it can establish connections to cloud servers through standard IP protocols.

Ideal for a broad spectrum of applications, the GW5000 is a key component in smart solutions for parking, fire safety, livestock tracking, asset management, cable monitoring in power systems, intelligent street lighting, precision agriculture, and environmental monitoring.



## Features

- Supports the standard LoRaWAN protocol with global frequency band options;
- Utilizes Semtech SX130X chips;
- 8 Data Channels and 1 control channel, with full-duplex/half-duplex options;
- Compatible with network servers such as Tencent Cloud, LinkWAN, TTN, Chirpstack, Amazon, etc.;
- Supports IPv6 and Modbus TCP protocol;
- Transmission range up to 15 kilometers;
- IP67 Protection Rating;
- Supports standard PoE (Power over Ethernet) power supply;
- Supports for Class A/B/C;
- Integrated WiFi/GPS/LTE/LoRa Antenna;
- Certified with CE and FCC.

## Dimensions(mm)

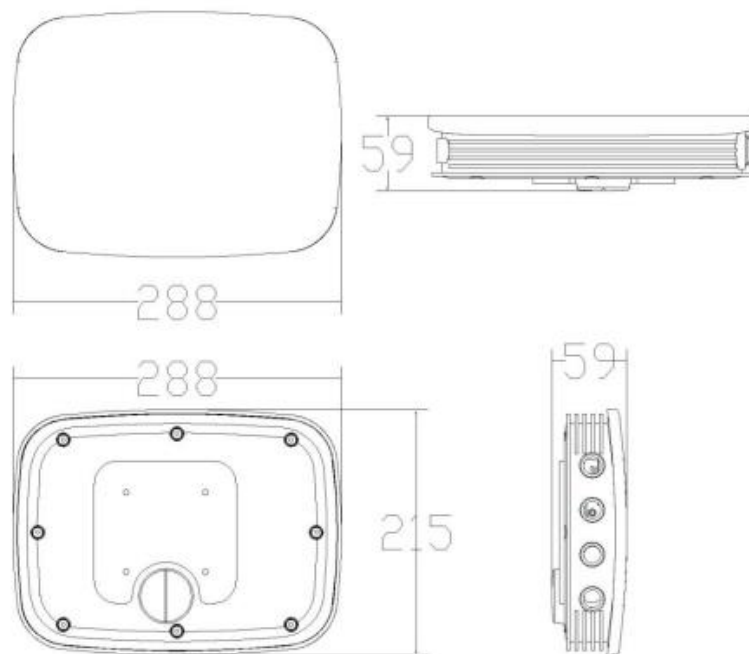

## Technical specifications and standards

Technical parameter	CPU	Industrial Grade CPU operating at 400MHZ
	Memory	64M DDR2 RAM, 16M SPI FLASH
	System	Linux-3.18.27 (32-bit system,128kB L2 cache )
Wireless parameter	LoRa data rate	292bps ~ 5.4Kbps
	Ethernet communication rate	100Mbps
	LTE communication rate	50Mbps
	Working frequency	CN470~510MHz EU863~870MHz; US902~928MHz; AS920~925MHz; AU915~928MHz; KR920~923MHz; RU864~870MHz IN865-867MHz
	Max transmission power	26dbm
	Rx sensitivity	-142dBm@SF12 (half-duplex)/-138dBm@SF12 (full-duplex)
	Channels	8 Data Channels , 1 Control Channel
	Communication interface	1*LAN , 1*WAN, 1*WIFI, 1*LTE module
	Electrical specification	Input
Power Consumption		7W
Working temperature		-40°C ~ 80°C
Working humidity		5% ~ 95% (no condensing)
Physical parameter	Ingress Protection	IP67
	Dimension	288mm*215mm*59mm



Installation	Wall-mounted or Pole-mounted
Certificate	CE/FCC
Thunder protection	Optional

## Configuration Guide

### How to connect indoor LoRaWAN® Gateway to QTLab?

#### Gateway connection

##### Mobile Phone Connection

1. Open the WiFi settings on your mobile phone and search for the gateway's hotspot. The hotspot name begins with WIFI - 05, followed by a 6 - character gateway ID (e.g., WIFI - 05\_e33223). The default password is gateway2018better.
2. Launch your mobile phone browser and enter 192.168.3.1 to access the gateway's web interface. Log in using the following credentials:
  - Username: root
  - Password: WelcomeTo2018

##### Laptop Connection

1. Use an Ethernet cable to connect the gateway's LAN port to your laptop.
2. Configure your laptop to obtain an IP address automatically.
3. Open Google Chrome and enter 192.168.3.1 in the address bar to access the gateway's web interface. Then, enter the login password WelcomeTo2018.

## Configuration

### Chirpstack

#### Network Server Address Setup

1. Log in to the gateway's WEB configuration interface. Navigate to Network → LoRa GW → Configuration to access the LoRa settings page.
2. Select the option to set the LoRa Network Server address. Enter the IP address of the ChirpStack server: 47.106.157.173.

#### Uplink and Downlink Port Configuration

1. The uplink and downlink ports depend on the UDP ports of the Network Server. You can click the Custom option to manually enter the UDP port numbers.
2. The current configurations for different frequency bands are as follows:



- **AS923:** Uses UDP port 1701
  - **AS923 - 2:** Uses UDP port 1702
  - **EU868:** Uses UDP port 1700
3. The communication protocol between the gateway and the Network Server is UDP.

## Gateway Addition on ChirpStack

1. Log in to the ChirpStack configuration interface. Navigate to Gateways → Add gateway.

	Last seen	Gateway ID	Name
<input type="checkbox"/>	Offline 2025-01-20 20:07:44	24e124ffef7c6c0	AS923
<input type="checkbox"/>	Offline 2025-01-23 05:59:58	24e124ffef5a52c	AS923-1
<input type="checkbox"/>	Offline 2025-01-09	0505f041c8e3ae14	AS923-SC

2. Copy the gateway ID from the LoRa Settings section of the gateway's WEB configuration interface.

3. On the Add gateway page, enter the gateway name and paste the gateway ID. Then, click Submit.



## Configuration of Application on ChirpStack

To configure an application on ChirpStack, follow these steps:

1. Navigate to the "Applications" page via the left - hand menu and
2. Click the "Add application" button.



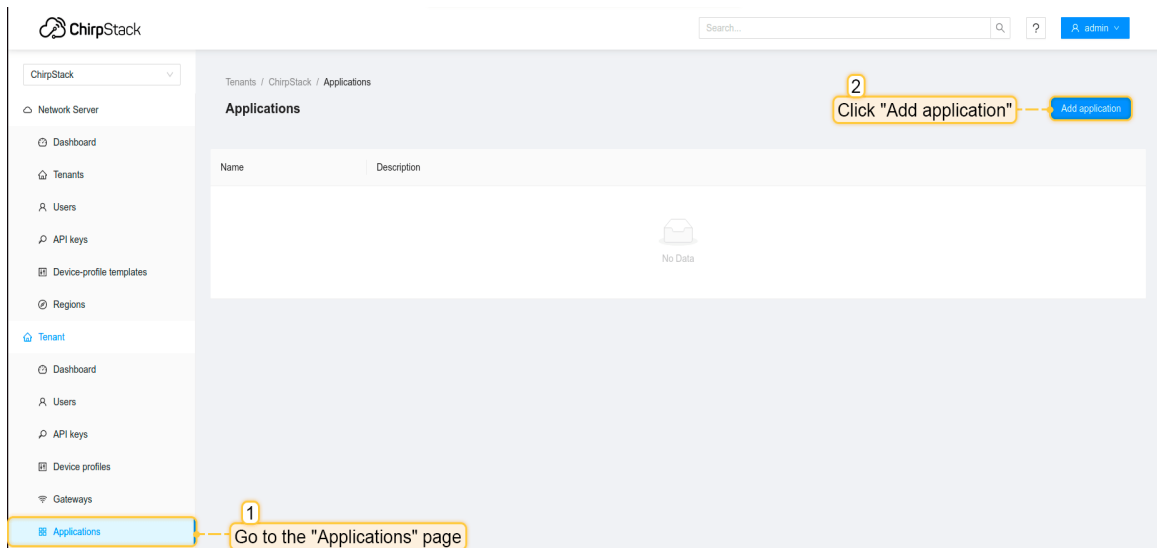

3. Enter the application name and
4. Click the "Submit" button.

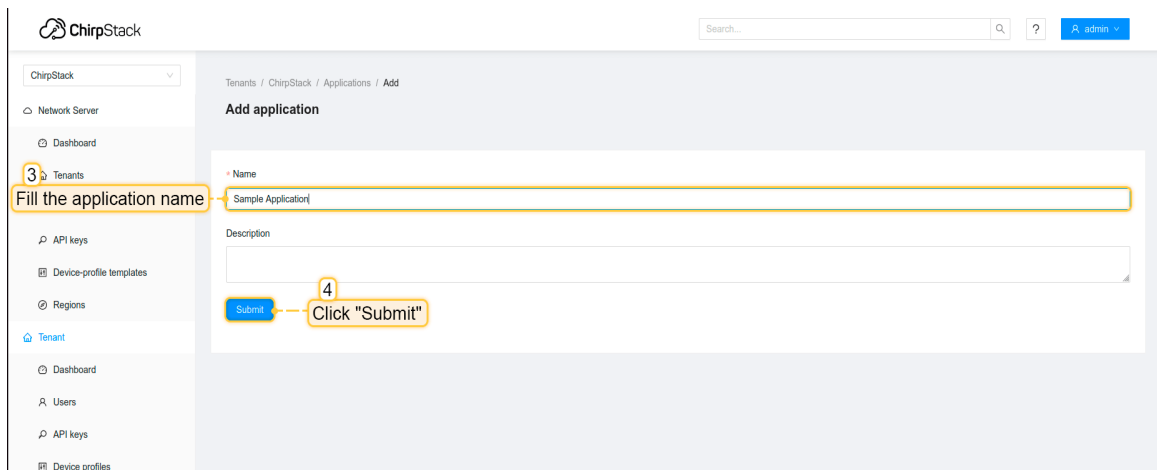

5. Access the API keys page from the left - hand menu and
6. Click the "Add API key" button.



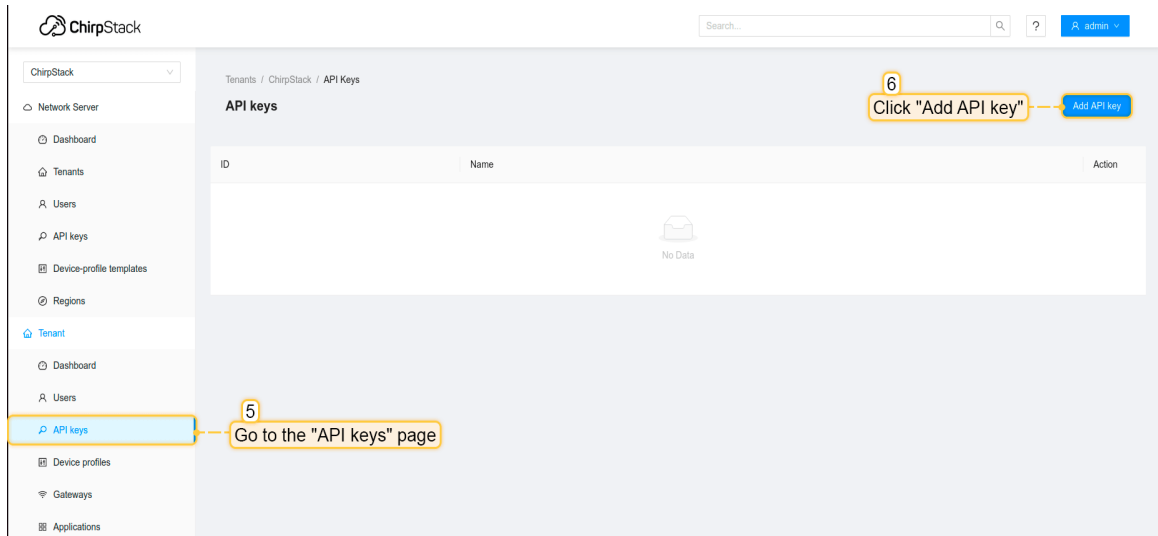

7. Provide a name for the API key and
8. Click the "Submit" button.

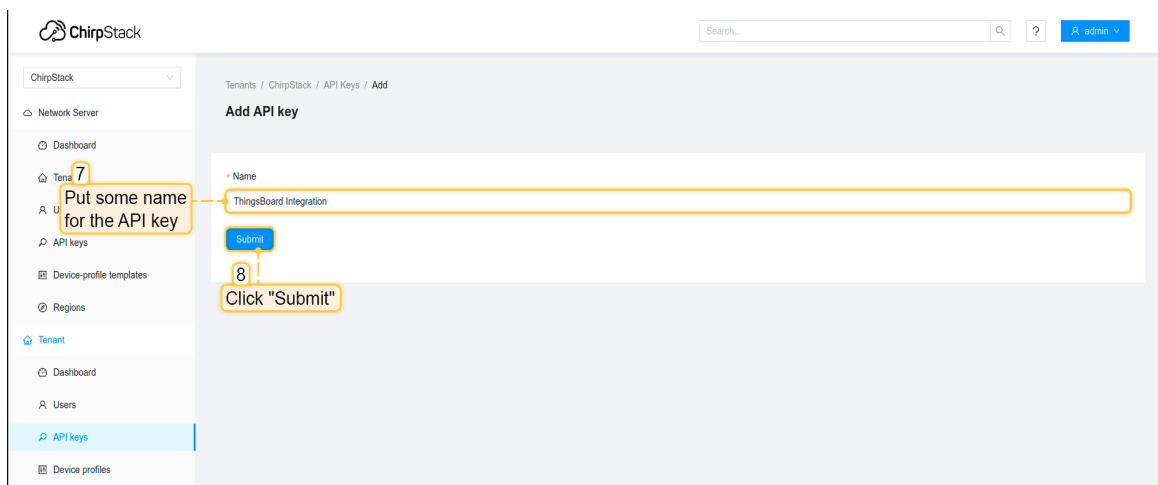

- Copy the generated API key and store it securely as it will be required for integration with QTLab.

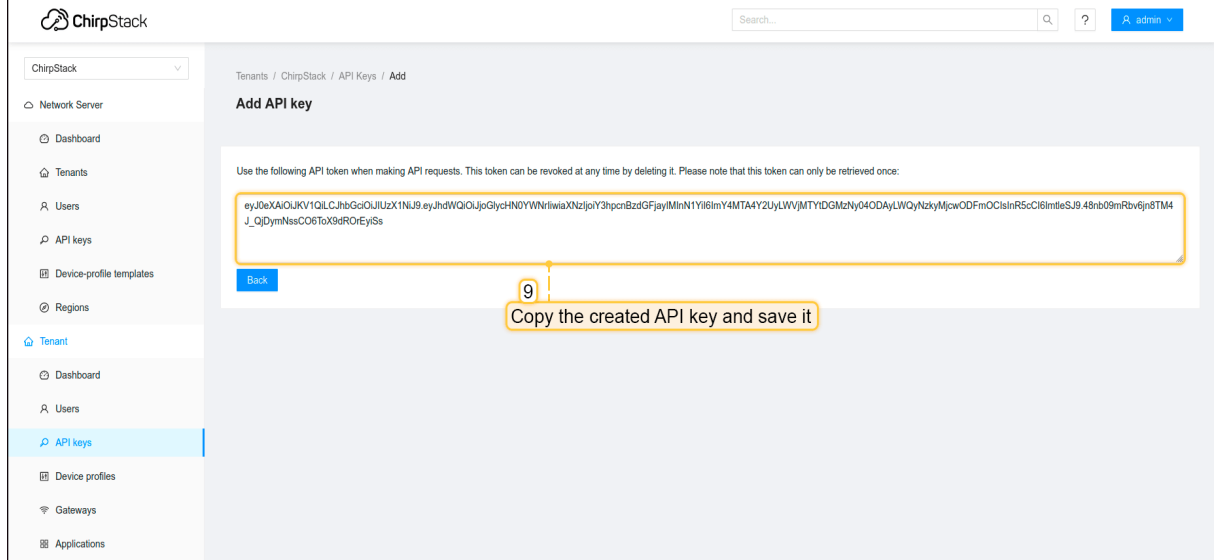

## Creation and Configuration of ChirpStack Integration in QTLab

Create an integration with ChirpStack within QTLab and configure it on ChirpStack as follows:

### Adding the Integration in QTLab

- Navigate to the "Integration center" section, specifically the "Integrations" page. Click the "plus" button to initiate the addition of a new integration. Select "Chirpstack" as the integration type and then click "Next".

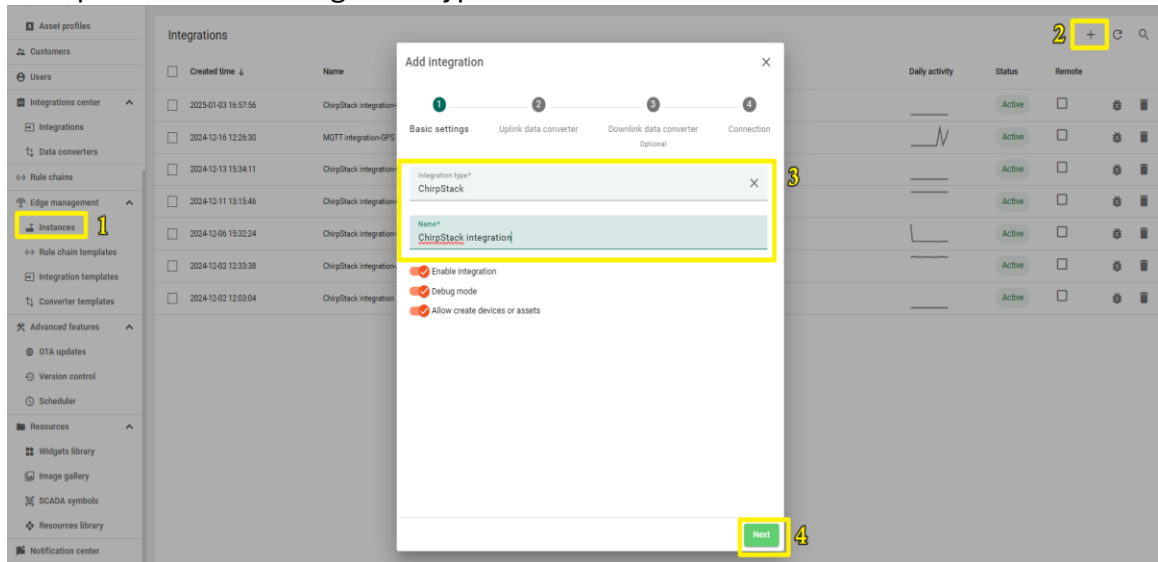

- Click "Next" again.



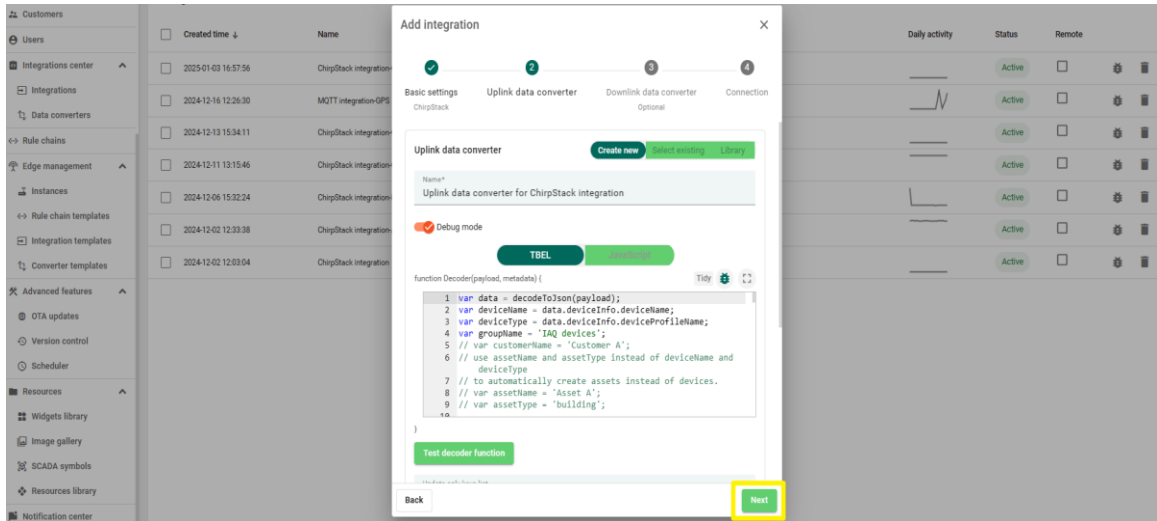

3. Leave the "Downlink data converter" field blank. Click the "Skip" button.

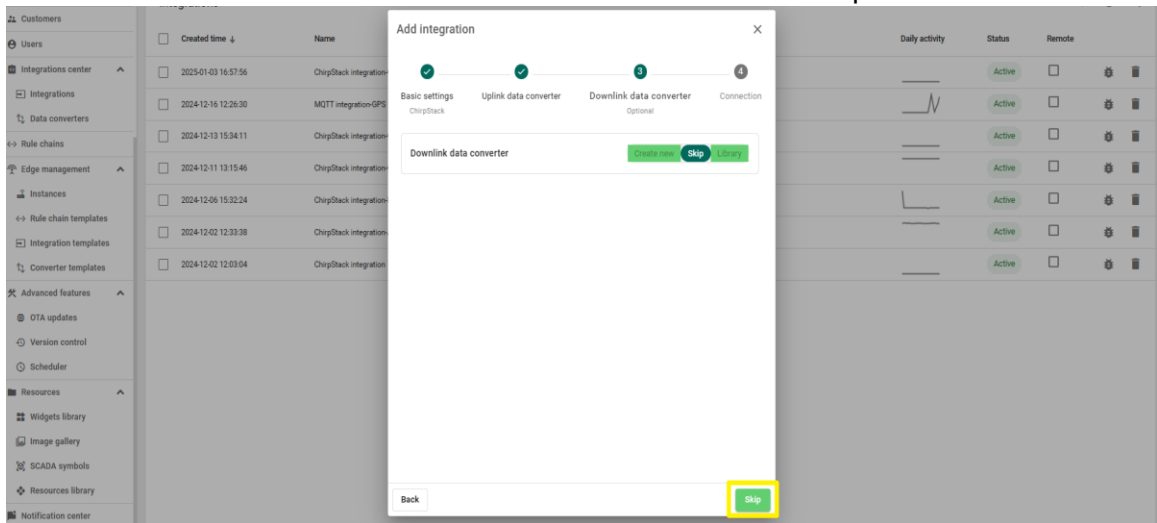

4. Input the "Application server URL" and "API Key" obtained from ChirpStack. Copy the "HTTP endpoint URL" and click the "Add" button.

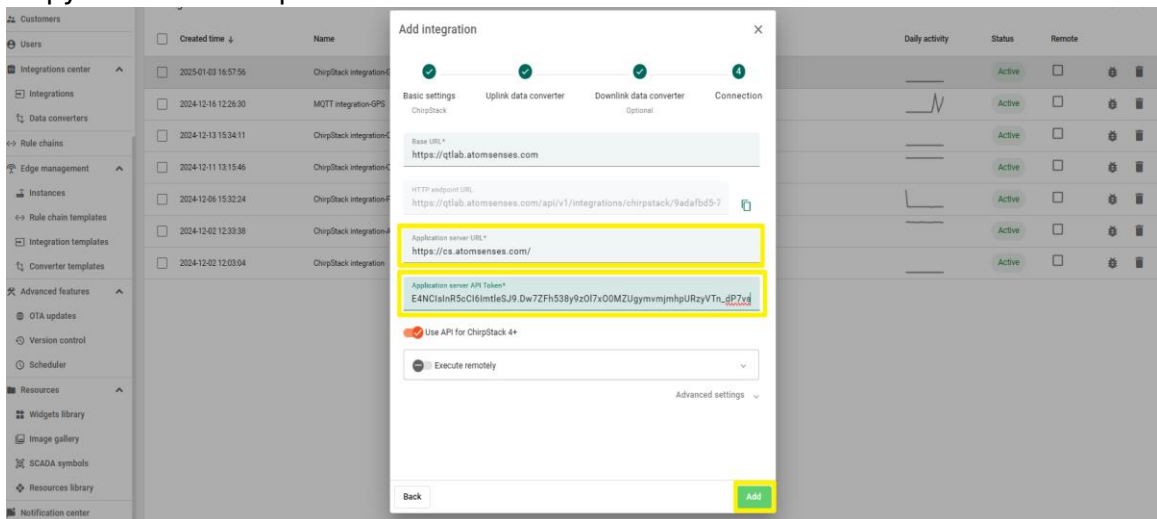

## Configuring the Integration on ChirpStack

1. Open your ChirpStack interface. Navigate to the "Applications" page, then select your specific application, and click on the "Integrations" tab. Locate and click on the HTTP tile.

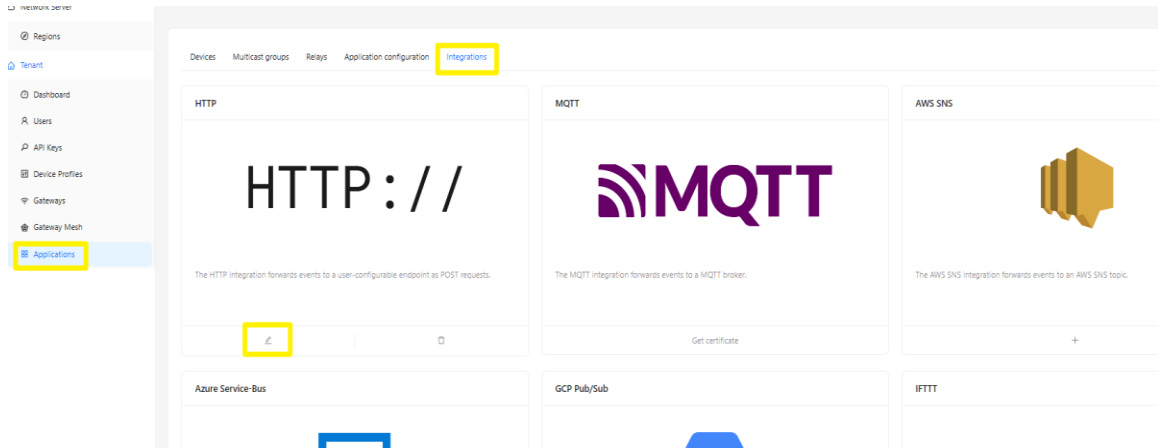

2. Paste the "HTTP URL endpoint" into the "Event Endpoint URL(s)" field and click the "Submit" button.

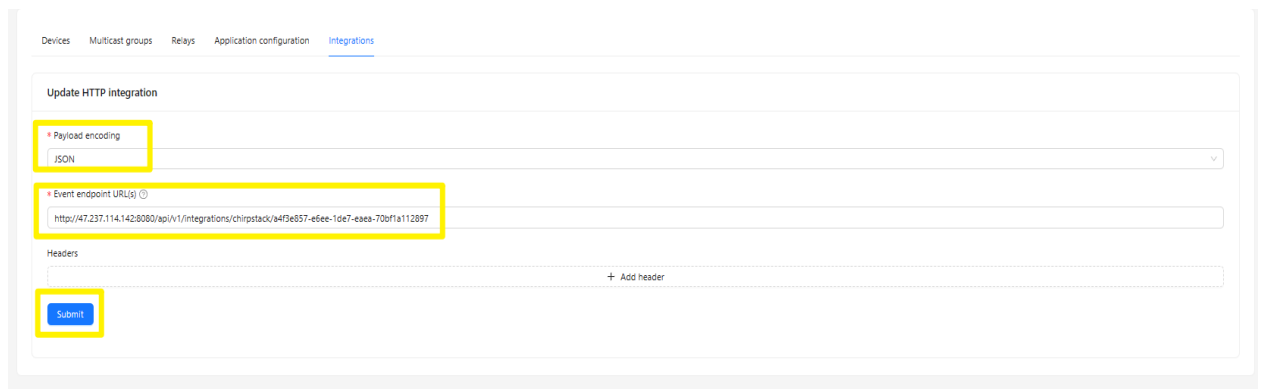

3. After above steps you should have the gateway connected to Thingsboard via Chirpstack.
4. After adding devices, by sending data from the device, it will appear on the corresponding device page in Thingsboard. You can view the data in the "Entities" -> "Devices" menu or by creating a dashboard

