

ELT Lite

Description

ELT Lite is a general LoRaWAN® device for measuring analog or digital signals. It is a 1-channel GPIO wireless transceiver and can also provide power to external sensors. ELT Lite is enclosed in an IP67 box and are designed to be mounted outside. It is the ideal sensor for measuring in advanced places or extreme weather conditions. ELT Lite has the capacity of measuring with remarkably long range.

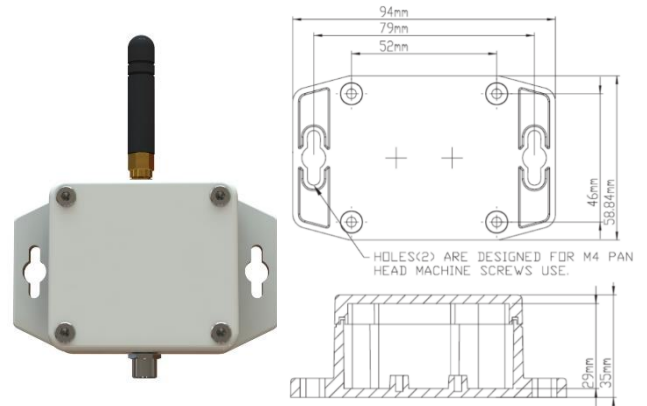

Applications

- Smart cities
- Agriculture
- Distance measuring
- Extreme weather conditions
- Exposed areas (containers e.g.)

Product features

- LoRaWAN Certified ^{CM}
- Compatible with LoRaWAN® 1.0.3
- Analog 0 – 10V input
- Digital input
- Pulse counter
- IP67 Classified
- Battery-powered
- NFC for configuration
- Configuration over the air

Device Specifications

Mechanical specifications

Weight	60 g excluding batteries / 100 g including batteries
Dimensions	94 x 59 x 35 mm
Enclosure	IP67
Direct connection to:	1-wire temperature sensor

Operating conditions

Temperature	-40 to 60 °C (85 °C with external power supply)
Humidity	0 to 100% RH

Device Power Supply

Battery Type	1 x 3.6V AA Lithium Battery
Expected Battery Life	< 10 years (Depending on configurations and environment)

Device Logging Function

Sampling Interval	Configurable via NFC and downlink configuration
Data Upload Interval	Configurable via NFC and downlink configuration

Radio / Wireless

Wireless Technology	LoRaWAN® 1.0.3
Wireless Security	LoRaWAN® End-to-End encryption (AES-CTR), Data Integrity Protection (AES-CMAC)
LoRaWAN Device Type	Class A/C (Configurable) End-device
Supported LoRaWAN features	OTAA, ABP, ADR, Adaptive Channel Setup
Link Budget	137 dB (SF7) to 151 dB (SF12)
Available Frequencies	US902 – 928, EU863 – 870, AS923, AU915 – 928, KR920 – 923, RU864, IN865
RF Transmit Power	14 dB / 20 dB (Region specific)

Data types

Type value	Type	Data size	Comment
0x07	VDD (Battery voltage)	2	0 – 65535 mV
0x08	Analog1	2	0 – 65535 mV
0x0A	Pulse count	2	0 – 65535 (Between two send intervals)
0x0B	Pulse count ABS	4	Absolute value 0 – 4294967295
0x0C	External temp1	2	-3276.5 °C – 3276.5 °C
0x0D	External digital/button	1	0 / 1 (On / Off, Down / Upp)
0x0E	External distance	2	0 – 65535 mm
0x10	External IR temperature	4	2 bytes internal temp, 2 bytes external temp. (-3276.5 °C – 3276.5 °C)
0x12	External water leak	1	0 – 255 (0 = no water detected)
0x3D	Debug information	4	Data depends on debug information
0x3E	Sensor settings	n	Sensor setting sent to server at startup (first package). Sent on Port+1.