

INSTALLATION AND MAINTENANCE MANUAL

WIRNET™ iFEMTOCELL



	Written by	Approved by	Approved by	Validated by
Name	BCA	BLT	VLO	MCH
Entity	DRD	DRD	DRD	DRD
Date	2018/11/16	2018/11/19	2018/11/21	2018/11/21



HISTORY

Date	Modification	Author	Version
2016-12-21	Preliminary version	SNI	0.1
2017-01-03	Update after review	PTA	0.2
2017-01-04	Update after review	SNI	0.3
2017-01-09	Update after review	PTA	0.4
2017-01-10	Update after review	SNI	0.5
2017-01-12	Approval of document	PTA	1.0
2017-01-17	Adding Power supply references	SNI	1.1
2017-02-03	Symbol reference (Sticker)	SNI	1.2
2017-09-18	Update after review (certification, power supplies, stickers)	VLO	1.3
2017/10/24	Official release	VLO	2.0
2018/11/09	§ 2.Update certification	VLO	2.1
2018/11/16	Describe Wi-Fi AP in §3.4.4.2, update web interface description (§3.4.5) and parameters (§4.2.3)	BCA	2.2
2018/11/21	Update Stickers §1.9	VLO	2.3
2018/11/21	Official release compatible with KerOS V4.0 Firmware	BCA	3.0

Classification	This document is the strict property of Kerlink and shall not be either copied nor sent without express written authorization of Kerlink	
Internal Use	Kerlink m2m technologies reserved rights	
Confidential	Kerlink – 1 rue Jacqueline Auriol – 35235 THORIGNÉ-FOUILLARD	Page 2 / 100
Strict confidential		

INDEX

1.	Description of the Wirnet™ iFemtoCell	14
1.1	Main functionalities.....	15
1.2	Hardware specifications	15
1.2.1	Design overview	15
1.2.2	Casing assembly	17
1.2.3	Casing characteristics	17
1.2.4	Casing dimensions.....	18
1.2.5	Brief description	19
1.2.6	Block diagram	21
1.3	Power Supply.....	23
1.3.1	CUI Inc – SMI6	23
1.3.2	DEE VAN – DSA-6PFG-12 Fxx.....	24
1.3.3	SL POWER – TE10A1203B01.....	25
1.3.4	MERRYKING – MKS-1200500DH.....	26
1.4	Power consumption	27
1.5	Omnidirectional LoRa antenna.....	27
1.5.1	Return loss.....	28
1.5.2	Radiation patterns.....	29
1.6	Internal Wi-Fi antenna	30
1.6.1	Return loss.....	30
1.6.2	Radiation patterns.....	31
1.7	LEDs description	32
1.8	Push buttons.....	33
1.8.1	Reset push button	34
1.8.2	WPS	34
1.9	Sticker.....	34
1.10	Wall Mounting.....	36
1.11	Radio specifications.....	37
1.11.1	Main characteristics	37

Classification	This document is the strict property of Kerlink and shall not be either copied nor sent without express written authorization of Kerlink	
Internal Use	Kerlink m2m technologies reserved rights	
Confidential	Kerlink – 1 rue Jacqueline Auriol – 35235 THORIGNÉ-FOUILLARD	Page 3 / 100
Strict confidential		

1.11.2	Radio front-end block diagram	38
1.11.3	Modulations and data rates	38
1.11.4	Frequency bands and channelization.....	39
1.11.5	Output Power	42
1.11.6	Out of band emissions.....	42
1.11.7	Sensitivity	43
1.11.8	RSSI and SNR.....	43
1.11.9	Out of band blockers rejection.....	44
1.11.9.1	868MHz	45
1.11.9.2	915MHz	45
1.11.9.3	923MHz	46
1.12	Description of the accessories	47
1.12.1	RJ45 cable	47
1.12.2	Debug tool	48
2.	Certifications	50
2.1	Wirnet™ iFemtoCell 868.....	50
2.1.1	Europe / CE.....	50
2.1.2	India.....	51
2.1.3	South Africa	52
2.1.4	Saudi Arabia.....	52
2.1.5	United Arab Emirates	53
2.1.6	Russia.....	54
2.2	Wirnet™ iFemtoCell 915.....	55
2.2.1	USA / FCC.....	56
2.2.2	Canada / IC	56
2.3	Wirnet™ iFemtoCell 923.....	58
2.3.1	Australia.....	59
2.3.2	New-Zealand	61
2.3.3	Japan.....	63
2.3.4	Taiwan	65
2.3.5	Hong Kong	67
2.3.6	Singapore.....	68

Classification	This document is the strict property of Kerlink and shall not be either copied nor sent without express written authorization of Kerlink	
Internal Use	Kerlink m2m technologies reserved rights	
Confidential	Kerlink – 1 rue Jacqueline Auriol – 35235 THORIGNÉ-FOUILLARD	Page 4 / 100
Strict confidential		

2.3.7	Thailand	70
2.3.8	South Korea	71
2.3.9	Vietnam	74
2.3.10	Malaysia.....	76
2.3.11	Brazil	78
2.3.12	Indonesia	80
2.3.13	Philippines	82
3.	Installation procedure	84
3.1	Installation topology	84
3.1.1	Wirnet™ iFemtoCell gateway installation	84
3.2	Mounting of the enclosure.....	86
3.2.1	General considerations	86
3.2.2	Distance between LoRa antenna and LTE USB dongle	87
3.3	Setting connections	87
3.4	Commissioning	88
3.4.1	USIM card	88
3.4.2	Power ON	89
3.4.3	Functional check.....	89
3.4.4	First connection.....	90
3.4.4.1	Ethernet connection	90
3.4.4.2	Wi-Fi connection	90
3.4.5	Configuration.....	91
4.	Maintenance of the Wirnet™ iFemtoCell.....	93
4.1	Simple checks	93
4.1.1	Wirnet™ iFemtoCell enclosure.....	93
4.1.2	User interface	93
4.2	Interfaces for debug or maintenance purposes.....	94
4.2.1	USB interface / Firmware upgrade.....	94
4.2.1.1	Overview	95
4.2.1.2	Specific Files	95
4.2.2	Push buttons.....	96
4.2.2.1	Reset push button.....	97

Classification	This document is the strict property of Kerlink and shall not be either copied nor sent without express written authorization of Kerlink	
Internal Use	Kerlink m2m technologies reserved rights	
Confidential	Kerlink – 1 rue Jacqueline Auriol – 35235 THORIGNÉ-FOUILLARD	Page 5 / 100
Strict confidential		

4.2.2.2	WPS	97
4.2.3	Local Web maintenance interface	97
5.	List of the accessories.....	97
6.	KERLINK support.....	99

Classification	This document is the strict property of Kerlink and shall not be either copied nor sent without express written authorization of Kerlink	
Internal Use	Kerlink m2m technologies reserved rights	
Confidential	Kerlink – 1 rue Jacqueline Auriol – 35235 THORIGNÉ-FOUILLARD	Page 6 / 100
Strict confidential		

FIGURES

Figure 1: LoRa network topology	13
Figure 2: Wirnet™ iFemtoCell product	14
Figure 3: Design overview	16
Figure 4: Casing assembly.....	17
Figure 5: Casing dimensions	18
Figure 6: Casing description	20
Figure 7: Hardware block diagram	21
Figure 8: LoRa antenna.....	27
Figure 9: LoRa antenna return loss.....	28
Figure 10: LoRa antenna radiation patterns.....	29
Figure 11: Wi-Fi antenna return loss	30
Figure 12: Wi-Fi antenna radiation patterns	31
Figure 13: LEDs	32
Figure 14: Push buttons.....	33
Figure 15: Push button tool.....	33
Figure 16: Sticker for WIFC 868	34
Figure 17: Sticker for WIFC 915	34
Figure 18: Sticker for WIFC 923	35
Figure 19: Wall mounting.....	36
Figure 20: Wall mounting dimensions.....	36
Figure 21: Front-end block diagram	38
Figure 22: Example of SNR, RSSI and RSSI+SNR plots at 125KHz BW / SF7.....	44
Figure 23: RJ45 T-568A plug	47
Figure 24: Debug tool connected to the Wirnet™ iFemtoCell	48
Figure 25: Channels allocation in Australia	60
Figure 26: Channels allocation in New-Zealand - Second configuration.....	62
Figure 27 : Channels allocation proposal in Japan	64
Figure 28 : Channels allocation proposal in Taiwan.....	66
Figure 29: Channels allocation in Hong Kong.....	68
Figure 30: Channels allocation in Singapore	69
Figure 31: Channels allocation in Thailand.....	71
Figure 32: KC minimum label	72
Figure 33: KC full label.....	72
Figure 34: Channels allocation I in South Korea	73
Figure 35: Channels allocation in Vietnam	75
Figure 36: Channels allocation in Malaysia	77
Figure 37: Channels allocation in Brazil.....	79
Figure 38: Channels allocation in Indonesia.....	81
Figure 39: Channels allocation in Philippines.....	83
Figure 40: Ethernet WAN connection	85
Figure 41: Wi-Fi WAN connection	85
Figure 42: LTE/HSPA/GPRS USB dongle WAN connection	86
Figure 43: Connections.....	87
Figure 44: Functional check with LEDs	89

Classification	This document is the strict property of Kerlink and shall not be either copied nor sent without express written authorization of Kerlink	
Internal Use	Kerlink m2m technologies reserved rights	
Confidential	Kerlink – 1 rue Jacqueline Auriol – 35235 THORIGNÉ-FOUILLARD	Page 7 / 100
Strict confidential		

Figure 45: Web interface login screen 91
 Figure 46: Board ID..... 92
 Figure 47: Maintenance check with LEDs..... 93
 Figure 48: USB dongle on the Wirnet™ iFemtoCell..... 94
 Figure 49: Push buttons..... 96
 Figure 50: Push button tool..... 96

Classification	This document is the strict property of Kerlink and shall not be either copied nor sent without express written authorization of Kerlink	
Internal Use	Kerlink m2m technologies reserved rights	
Confidential	Kerlink – 1 rue Jacqueline Auriol – 35235 THORIGNÉ-FOUILLARD	Page 8 / 100
Strict confidential		

REFERENCES

Reference	Document / link	Description
[1]	https://lora-alliance.org/lorawan-for-developers	LoRaWAN™ Specification V1.1 2017 October
[2]	https://lora-alliance.org/lorawan-for-developers	LoRaWAN™ 1.1 Regional Parameters Revision B, 2018 January
[3]	E-CON-Product_Description_Wirnet_iFemtoCell-V3.0.pdf	Wirnet™ iFemtoCell Product Description

Classification	This document is the strict property of Kerlink and shall not be either copied nor sent without express written authorization of Kerlink	
Internal Use	Kerlink m2m technologies reserved rights	
Confidential	Kerlink – 1 rue Jacqueline Auriol – 35235 THORIGNÉ-FOUILLARD	Page 9 / 100
Strict confidential		

GLOSSARY

Abbreviation	Description
ADC	Analog to Digital Converter
AES	Advanced Encryption Standard
AGC	Automatic Gain Control
ANATEL	Agência NAcional de TELecomunicações (Brazilian agency of telecommunications)
AP	Access Point
APAC	Asia PACific
APC	Automated Power Control
API	Application Programming Interface
APN	Access Point Name
ARM	Advanced RISC Machine
BER	Bit error Rate
BLER	Block Error rate
BTS	Base Transceiver Station
BW	Band Width
CAN	Control Area Network
CPU	Central Processing Unit
DAC	Digital to Analog Converter
DDR	Double Data Rate
DDRAM	Double Data Rate RAM
DHCP	Dynamic Host Configuration Protocol
DIN	Deutsches Institut für Normung (German Institute for Standardization)
DOTA	Download Over The Air
EDGE	Enhanced Data rates for GSM Evolution
EIRP	Equivalent Isotropically Radiated Power
EMC	ElectroMagnetic Compatibility
eMMC	Embedded Multi Media Card
FCC	Federal Communications Commission
FER	Frame Error Rate
FPGA	Field Programmable Gate Array
FTP	File Transfer Protocol
GMSK	Gaussian Minimum Shift Keying
GPIO	General Purpose Input Output
GPRS	General Packet Radio Service
GPS	Global Positioning System
GSM	Global System for Mobile communication

Classification	This document is the strict property of Kerlink and shall not be either copied nor sent without express written authorization of Kerlink	
Internal Use	Kerlink m2m technologies reserved rights	
Confidential	Kerlink – 1 rue Jacqueline Auriol – 35235 THORIGNÉ-FOUILLARD	Page 10 / 100
Strict confidential		

HSPA	High Speed Packet Access
HTTP	HyperText Transfer Protocol
IC	Integrated Circuit or Industry Canada
IK	Mechanical Impact
IO	In / Out
IoT	Internet of Things
IP	Internet Protocol or Ingress Protection
ISM	Industrial Scientific and Medical
I2C	Inter Integrated Circuit
KLK	KERLINK
KNET	KERLINK M2M network
LBT	Listen Before Talk
LDO	Low Drop Out
LED	Light-Emitting Diode
LNA	Low Noise Amplifier
LoRa	Long Range
LTE	Long Term Evolution
LUT	Look Up table
M2M	Machine to Machine
MIPS	Millions of Instructions Per Second
MFLOPS	Million Floating-point Operations Per Second
NFS	Network File System
PA	Power Amplifier
PC	Personal Computer or Polycarbonate
PCB	Printed Circuit Board
PCI	Peripheral Component Interconnect
PER	Packet Error Rate
PLL	Phase Locked loop
RAM	Random Access Memory
RF	Radio Frequency
RSSI	Received Signal Strength Indicator
RTC	Real Time Clock
RX	Receive
SAW	Surface Acoustic Wave
SDIO	Secure Digital Input Output
SI	Système d'Information
SIM	Subscriber Identity Module
SMA	SubMiniature version A
SNR	Signal to Noise Ratio

Classification	This document is the strict property of Kerlink and shall not be either copied nor sent without express written authorization of Kerlink	
Internal Use	Kerlink m2m technologies reserved rights	
Confidential	Kerlink – 1 rue Jacqueline Auriol – 35235 THORIGNÉ-FOUILLARD	Page 11 / 100
Strict confidential		

SPDT	Single Pole Double Throw
SPI	Serial Peripheral Interface bus
SSH	Secure Shell
SSTP	Screened Shielded Twisted Pair
STP	Shielded Twisted Pair
TBD	To Be Defined
TCP	Transmission Control Protocol
TPE	ThermoPlastic Elastomer
TX	Transmit
UART	Universal Asynchronous Receiver Transmitter
UFL	Miniature coaxial RF connector manufactured by Hirose Electric Group
UICC	Universal Integrated Circuit Card
UMTS	Universal Mobile Telecommunications System
USB	Universal Serial Bus
USIM	Universal Subscriber Identity Module
UV	UltraViolet
WAN	Wide Area Network
WLAN	Wireless Local Area Network
WPS	Wi-Fi Protected Setup
3G	Third generation of mobile telecommunications technology
3GPP	3rd Generation Partnership Project
4G	Fourth generation of mobile telecommunications technology

Classification	This document is the strict property of Kerlink and shall not be either copied nor sent without express written authorization of Kerlink	
Internal Use	Kerlink m2m technologies reserved rights	
Confidential	Kerlink – 1 rue Jacqueline Auriol – 35235 THORIGNÉ-FOUILLARD	Page 12 / 100
Strict confidential		

INTRODUCTION

The Wirnet™ iFemtoCell gateway is part of the global Long Range Radio fixed network to provide M2M connectivity link between low power end-point and Internet Access. The gateway architecture is specifically designed for the needs of indoor environment.

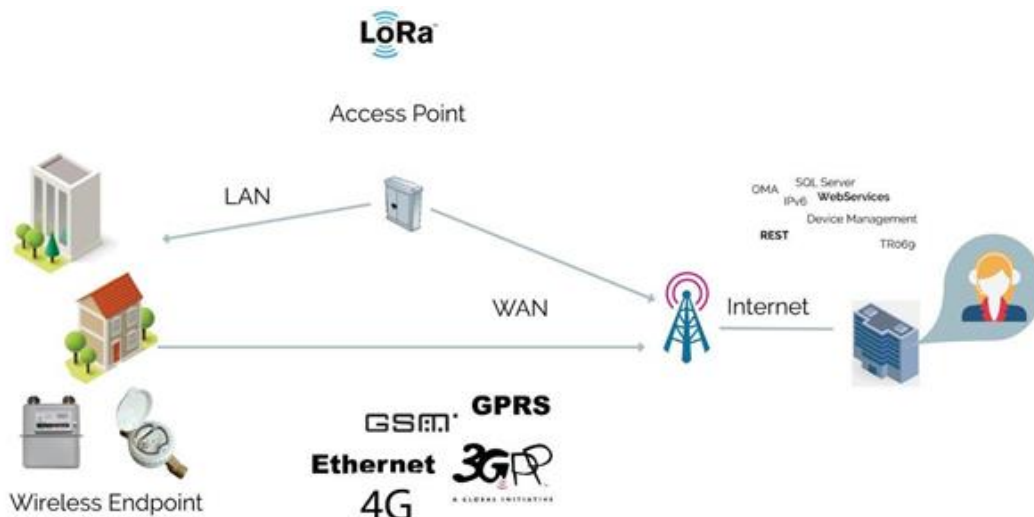

Figure 1: LoRa network topology

The Wirnet™ iFemtoCell is based on “LoRa” technology provided by Semtech Company. It is compatible and interoperable with existing LoRa LPWAN.

Wirnet™ iFemtoCell is declined into three versions to cover different countries and areas around the world:

	Wirnet iFemtoCell 868	Wirnet iFemtoCell 915	Wirnet iFemtoCell 923
<i>geographical area</i>	Europe, Russia Africa Middle East, India	North America Central America South America with the exception of Brazil	Asia : Indonesia, Malaysia, Korea, Japan, Taiwan, Hong Kong, Thailand, Vietnam, Papua New Guinea, Singapore, Philippines Oceania : Australia, New Zealand Brazil
<i>ISM band</i>	863 - 876 MHz	902 - 928 MHz	915 - 928 MHz
<i>Downstream bandwidth (Tx of the Wirnet iFemtoCell)</i>	863 - 873MHz	902 - 928 MHz	915 - 928 MHz
<i>Upstream bandwidth (Rx of the Wirnet iFemtoCell)</i>	863 - 873 MHz	902 - 928 MHz	915 - 928 MHz
<i>Certifications</i>	See paragraph 2.1	See paragraph 2.2	See paragraph 2.3

Please check the appropriate version for the dedicated country. Contact KERLINK if required. The present document addresses all the above Wirnet™ iFemtoCell versions.

Classification	This document is the strict property of Kerlink and shall not be either copied nor sent without express written authorization of Kerlink	
Internal Use	Kerlink m2m technologies reserved rights	
Confidential	Kerlink – 1 rue Jacqueline Auriol – 35235 THORIGNÉ-FOUILLARD	Page 13 / 100
Strict confidential		

1. Description of the Wirnet™ iFemtoCell



Figure 2: Wirnet™ iFemtoCell product

Classification	This document is the strict property of Kerlink and shall not be either copied nor sent without express written authorization of Kerlink	
Internal Use	Kerlink m2m technologies reserved rights	
Confidential	Kerlink – 1 rue Jacqueline Auriol – 35235 THORIGNÉ-FOUILLARD	Page 14 / 100
Strict confidential		

1.1 Main functionalities

Here are the main functionalities of the Wirnet™ iFemtoCell product:

- LongRange support:
 - Incorporate LoRa (TM) bidirectional communications technology:
 - 868 version => RX: 863- 873MHz , TX: 863-873MHz (according to HW capabilities)
 - 915 version => 902-928 MHz ISM (according to HW capabilities)
 - 923 version => RX: 915-928 MHz, TX: 915-928MHz (according to HW capabilities)
 - 49 LoRa demodulators over 9 channels + 1 x GFSK
- Embedded, remote and open low power communication station
- Open development framework based on standard Linux OS
- WAN connectivity over Wi-Fi, Ethernet or LTE/HSPA/GPRS (with USB dongle)
- USB host interface allowing:
 - Local software upgrade with simple USB mass-storage key

1.2 Hardware specifications

1.2.1 Design overview

The Wirnet™ iFemtoCell is built on a plastic casing of around 160 x 90 x 35 mm.
The following pictures show the casing:



Classification	This document is the strict property of Kerlink and shall not be either copied nor sent without express written authorization of Kerlink	
Internal Use	Kerlink m2m technologies reserved rights	
Confidential	Kerlink – 1 rue Jacqueline Auriol – 35235 THORIGNÉ-FOUILLARD	Page 15 / 100
Strict confidential		



Figure 3: Design overview

Classification	This document is the strict property of Kerlink and shall not be either copied nor sent without express written authorization of Kerlink	
Internal Use	Kerlink m2m technologies reserved rights	
Confidential	Kerlink – 1 rue Jacqueline Auriol – 35235 THORIGNÉ-FOUILLARD	Page 16 / 100
Strict confidential		

1.2.2 Casing assembly

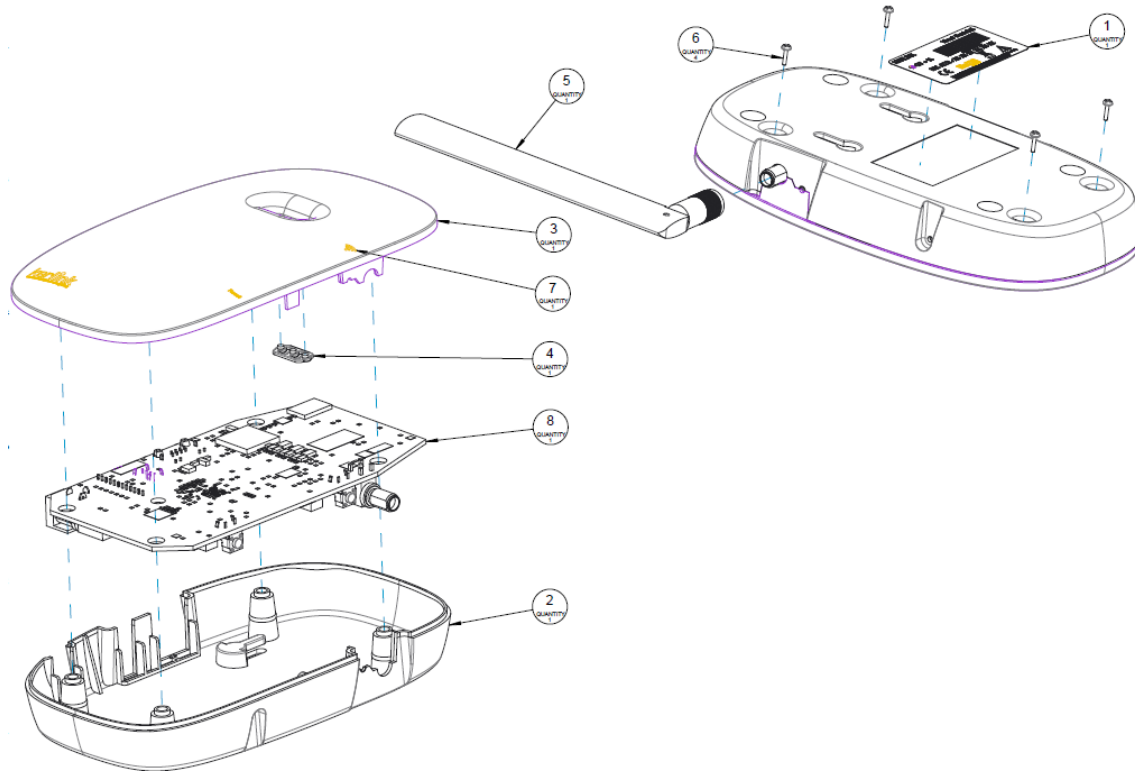

Figure 4: Casing assembly

1.2.3 Casing characteristics

The main characteristics of the enclosure are detailed hereafter:

Description	Specification
Enclosure material	PC + ABS
LED gasket material	Elastomer compound based on styrene-butadiene-styrene (SBS)
Color	RAL 9003
Dimensions without LoRa antenna	160 x 90 x 35 mm
Dimensions with LoRa antenna	220 x 125 x 35 mm
Weight with AC power supply and LoRa Antenna	280g
Ingress protection	IP31 / EN 60529
Humidity	95% non-condensing
Impact resistance	IK07
Flammability rating	UL94-V0
Wirnet™ iFemtoCell casing operating temperature range	-20°C to +55°C
Connectors	1 x SMA or RP-SMA (LoRa antenna) 1 jack connector (power supply)

Classification	This document is the strict property of Kerlink and shall not be either copied nor sent without express written authorization of Kerlink	
Internal Use	Kerlink m2m technologies reserved rights	
Confidential	Kerlink – 1 rue Jacqueline Auriol – 35235 THORIGNÉ-FOUILLARD	Page 17 / 100
Strict confidential		

1 x USB
1 x RJ45

1.2.4 Casing dimensions

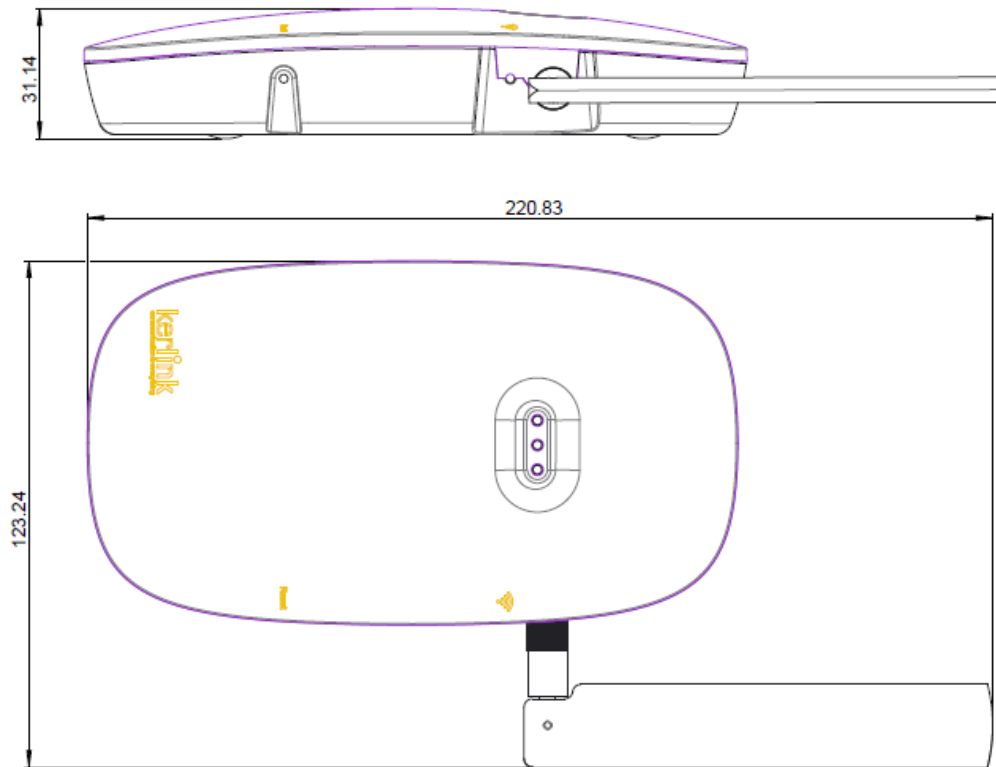
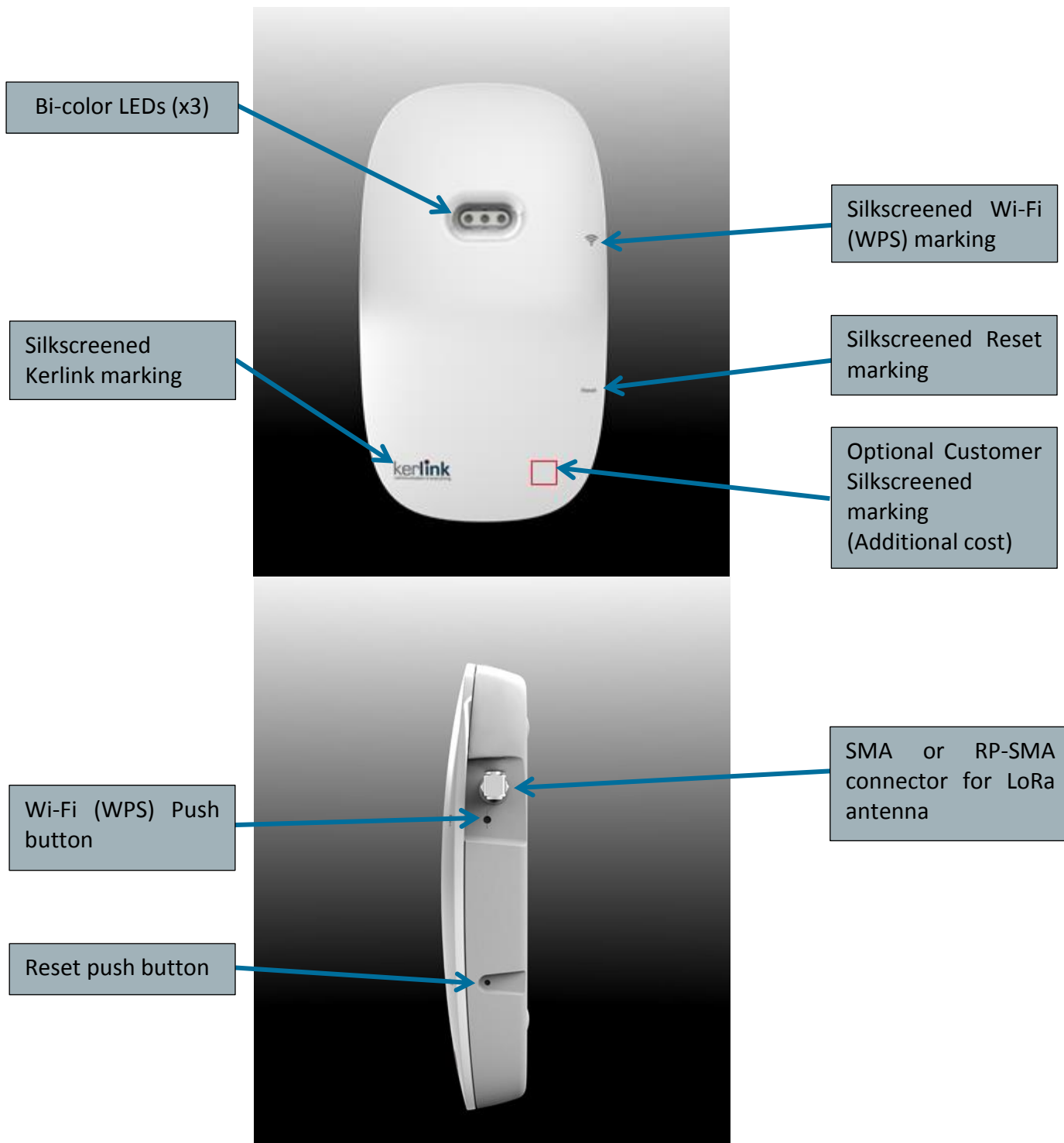

Figure 5: Casing dimensions

Classification	This document is the strict property of Kerlink and shall not be either copied nor sent without express written authorization of Kerlink	
Internal Use	Kerlink m2m technologies reserved rights	
Confidential	Kerlink – 1 rue Jacqueline Auriol – 35235 THORIGNÉ-FOUILLARD	Page 18 / 100
Strict confidential		

1.2.5 Brief description



Classification	This document is the strict property of Kerlink and shall not be either copied nor sent without express written authorization of Kerlink	
Internal Use	Kerlink m2m technologies reserved rights	
Confidential	Kerlink – 1 rue Jacqueline Auriol – 35235 THORIGNÉ-FOUILLARD	Page 19 / 100
Strict confidential		

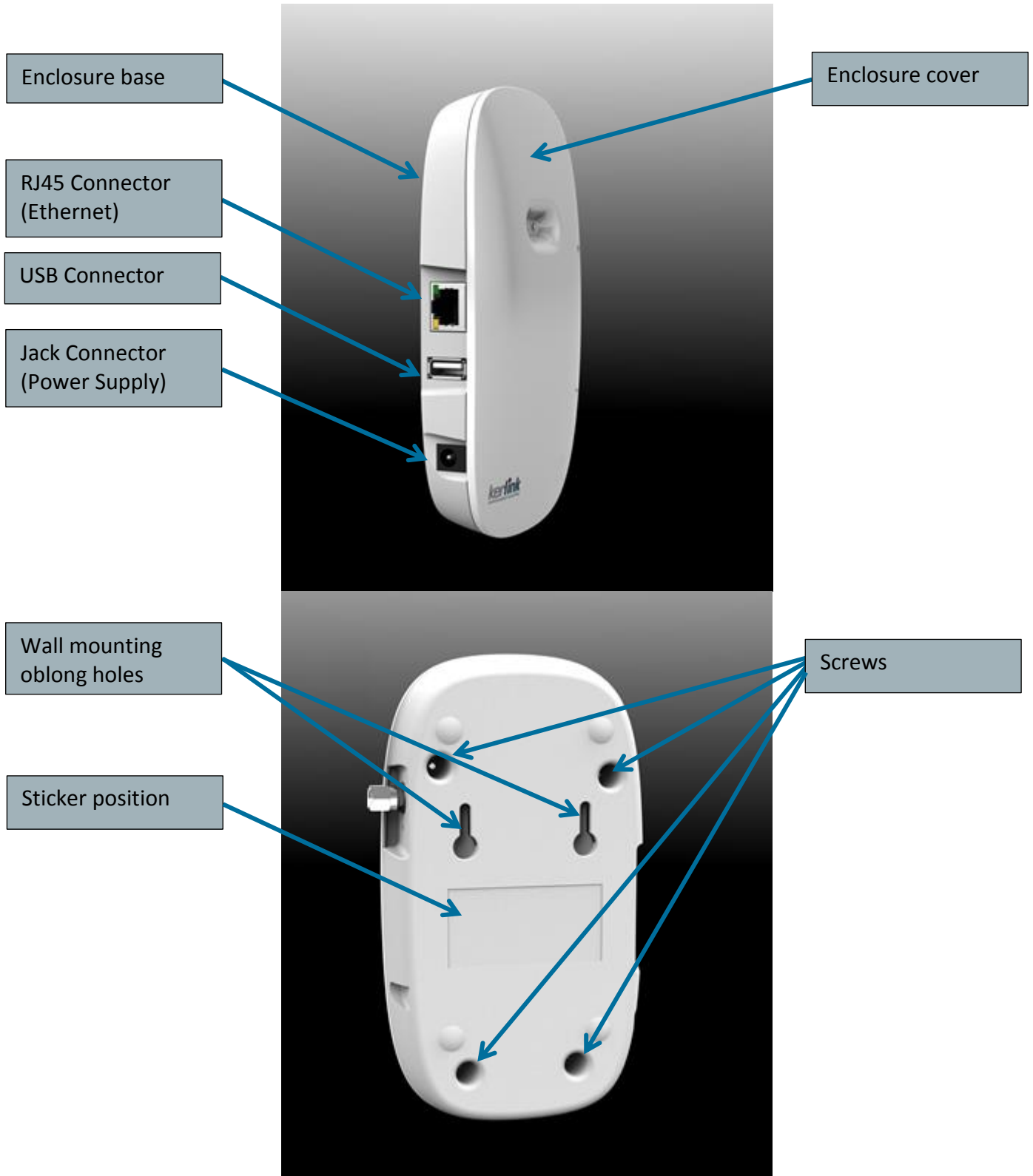
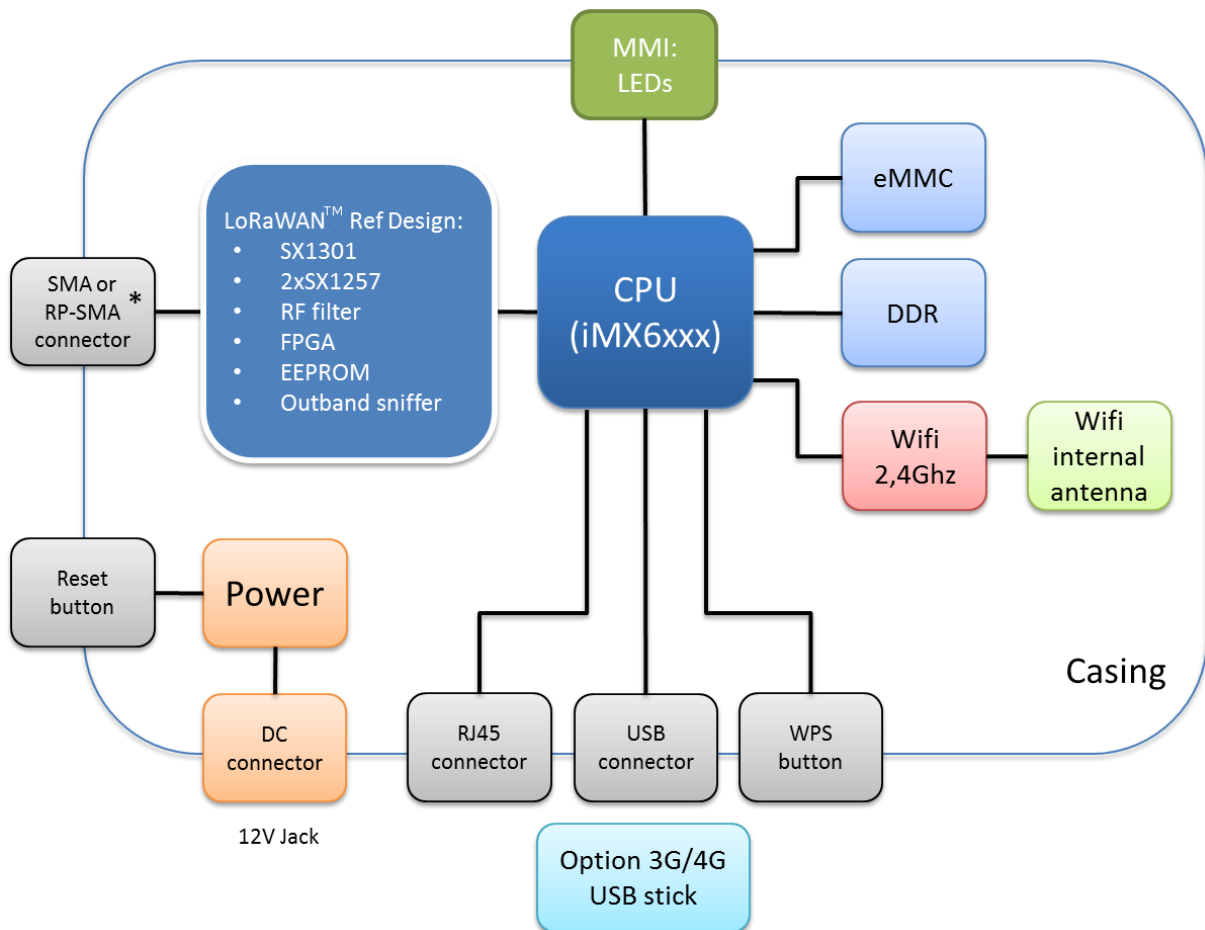

Figure 6: Casing description

Classification	This document is the strict property of Kerlink and shall not be either copied nor sent without express written authorization of Kerlink	
Internal Use	Kerlink m2m technologies reserved rights	
Confidential	Kerlink – 1 rue Jacqueline Auriol – 35235 THORIGNÉ-FOUILLARD	Page 20 / 100
Strict confidential		

1.2.6 Block diagram

The block diagram below depicts the HW architecture of the Wirnet™ iFemtoCell:



* SMA for 868 MHz version and RP-SMA for 915 MHz and 923 MHz versions

Figure 7: Hardware block diagram

Classification	This document is the strict property of Kerlink and shall not be either copied nor sent without express written authorization of Kerlink	
Internal Use	Kerlink m2m technologies reserved rights	
Confidential	Kerlink – 1 rue Jacqueline Auriol – 35235 THORIGNÉ-FOUILLARD	Page 21 / 100
Strict confidential		

Feature	Description
Processor	ARM Cortex A9, 800MHz core
Memories	256MB DDRAM – Volatile memory 8GB eMMC– Non-volatile memory
Watchdog	Hardware type
Security	Secure core Information encryption Secure Boot Secure software download
RTC	RTC clock (no back-up battery)
Power	External AC/DC – 12V/500mA Jack 2.5mm/5.5mm Integrated power management unit in CPU
Ethernet	10/100 Base-T 1 x RJ45 with activity LEDs
USB	USB Host HS type A 4G key or firmware upgrade & debug usage
WLAN	Wi-Fi chipset 2.4GHz 802.11 abgn Client and AP modes Internal Wi-Fi Antenna WPS button
LoRa Radio	Semtech Sx1301 + SX1257x2 + FPGA + EEPROM TX power 27dBm Outband radio sniffer RF external antenna (SMA connector) 3 versions of radio filter: 868 MHz 923 MHz 915 MHz
DEBUG	UART interface only available inside enclosure Loss of warranty if enclosure is opened Optional Debug tool to be used for UART to USB adaptation
Auto test	Internal power supplies check Interfaces and peripherals check
User interface	LED 1: Power LED 2: Backhaul connection LED 3: LoRa usage (Tx/Rx) Reset button
Operating temperature range	-20 to +55°C (product with SL POWER – TE10A1203B01 – AC/DC Power Supply) 0 to +40°C (product with CUI Inc – SMI6 – AC/DC Power Supply) 0 to +50°C (product with DEE VAN – DSA-6PFG-12 Fxx – AC/DC Power Supply) -20 to 60°C (product with MERRYKING - MKS-1200500DH - AC/DC Power Supply)

Classification	This document is the strict property of Kerlink and shall not be either copied nor sent without express written authorization of Kerlink	
Internal Use	Kerlink m2m technologies reserved rights	
Confidential	Kerlink – 1 rue Jacqueline Auriol – 35235 THORIGNÉ-FOUILLARD	Page 22 / 100
Strict confidential		

1.3 Power Supply

The power supply characteristics are detailed in the following paragraphs.

- DEE VAN – DSA-6PFG-12 FEU : provided with WIFC 868 (EMEA)
- DEE VAN – DSA-6PFG-12 FUS: provided with WIFC 915 (Americas)
- SL POWER – TE10A1203B01: alternate source for WIFC 868 (EMEA) and WIFC 915 (Americas) but not provided in the nominal package
- CUI Inc – SMI6: alternate source for WIFC 868 (EMEA) and WIFC 915 (Americas) but not provided in the nominal package
- Merryking - MKS-1200500DH: provided with WIFC 923 (APAC)

1.3.1 CUI Inc – SMI6

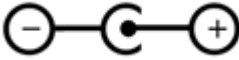
Description	Specification
Reference	CUI Inc – SMI6
Output Power	6 Watts (Guaranteed)
Output Voltage	12 VDC
Input Power Requirements	AC Input Voltage: 90 to 264 VAC AC Input Current: 0.3A @90-264VAC AC Frequency: 47 to 63 Hz
Dimensions	40.5 mm (W) x 30 mm (H) x 64 mm (L)
Weight	70g
Connectors	Jack 2.5mm/5.5mm
Polarity	 Positive polarity
Operating Ambient Temperature	0°C to +40°C @ 6W
Operating Humidity	Maximum 80%, Non-condensing
Storage Temperature	-10°C to +70°C
Storage Humidity	Maximum 90%, Non-condensing
Cable length	1.5 meters
Regulatory compliance	RoHS CE Limited Power Source recognised
Electromagnetic Emission & Immunity	FCC Part 15, Class B EN 55022 Class B (Emissions) EN 55024 (Immunity)
Safety Approvals	IEC 60950-1

Note 1: This power supply is intended for indoor applications only.

Classification	This document is the strict property of Kerlink and shall not be either copied nor sent without express written authorization of Kerlink	
Internal Use	Kerlink m2m technologies reserved rights	
Confidential	Kerlink – 1 rue Jacqueline Auriol – 35235 THORIGNÉ-FOUILLARD	Page 23 / 100
Strict confidential		

1.3.2 DEE VAN – DSA-6PFG-12 Fxx

Description	Specification
Reference	DSA-6PFG-12 Fxx
Output Power	6 Watts (Guaranteed)
Output Voltage	12 VDC
Input Power Requirements	AC Input Voltage: 90 to 264 VAC AC Input Current: 0.2A @90-264VAC AC Frequency: 47 to 63 Hz
Dimensions	26 mm (W) x 72.2 mm (H) x 67 mm (L)
Weight	72g
Connectors	Jack 2.5mm/5.5mm
Polarity	 Positive polarity
Operating Ambient Temperature	0°C to +50°C @ 6W
Operating Humidity	Maximum 80%, Non-condensing
Storage Temperature	-20°C to +60°C
Storage Humidity	Maximum 85%, Non-condensing
Cable length	2 meters
Regulatory compliance	RoHS CE Limited Power Source recognised
Electromagnetic Emission & Immunity	FCC Part 15, Class B (DSA-6PFG-12 FUS) EN 55022 (Emissions) (DSA-6PFG-12 FEU)
Safety Approvals	IEC 60950-1 (DSA-6PFG-12 FEU) UL60950-1) (DSA-6PFG-12 FUS)

Note 1: This power supply is intended for indoor applications only.

Classification	This document is the strict property of Kerlink and shall not be either copied nor sent without express written authorization of Kerlink	
Internal Use	Kerlink m2m technologies reserved rights	
Confidential	Kerlink – 1 rue Jacqueline Auriol – 35235 THORIGNÉ-FOUILLARD	Page 24 / 100
Strict confidential		



1.3.3 SL POWER – TE10A1203B01

Description	Specification
Reference	TE10A1203B01
Output Power	12 Watts
Output Voltage	12 VDC
Input Power Requirements	AC Input Voltage: 100 to 240 VAC AC Input Current: 0.28A @90-264VAC AC Frequency: 47 to 63 Hz
Dimensions	47 mm (W) x 38 mm (H) x 84 mm (L)
Weight	110g
Connectors	Jack 2.5mm/5.5mm
Polarity	 Positive polarity
Operating Ambient Temperature	-20°C to +70°C @ 8W
Operating Humidity	Maximum 80%, Non-condensing
Storage Temperature	-40°C to +95°C
Storage Humidity	Maximum 95%, Non-condensing
Cable length	1.5 meters
Regulatory compliance	RoHS CE Limited Power Source recognised
Electromagnetic Emission & Immunity	FCC Part 15, Class B EN 55022 (Emissions class B) EN 55024 (Immunity)
Safety Approvals	IEC 60950-1 UL60950-1

Note 1: This power supply is intended for indoor applications only.

Classification	This document is the strict property of Kerlink and shall not be either copied nor sent without express written authorization of Kerlink	
Internal Use	Kerlink m2m technologies reserved rights	
Confidential	Kerlink – 1 rue Jacqueline Auriol – 35235 THORIGNÉ-FOUILLARD	Page 25 / 100
Strict confidential		

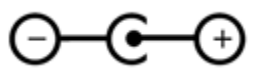
1.3.4 MERRYKING – MKS-1200500DH

Description	Specification
Supplier	Merryking
Reference	MKS-1200500DH
Output Power	6 Watts
Output Voltage	12 VDC +/-0.6V
Input Power Requirements	AC Input Voltage: 90 to 264 VAC AC Input Current: 0.30 A @ 90-264 VAC Inrush current: 40A max @ 100-264 VAC at 25°C AC Frequency: 47 to 63 Hz Efficiency > 78%
Dimensions	40 mm (W) x 32 mm (H) x 62 mm (L)
Weight	150 g
Connectors	Jack 2.5 mm / 5.5 mm
Polarity	 Positive polarity
Operating Ambient Temperature	-20°C to +60°C @ 6W
Operating Humidity	Maximum 90%, Non-condensing
Storage Temperature	-30°C to +70°C
Storage Humidity	Maximum 90%, Non-condensing
Cable length	1.5 meters
Regulatory compliance	UL/cUL/FCC CE/CB/GS PSE/KC/CCC SAA/C-Tick DOE VI/ RoHS
Electromagnetic Emission & Immunity	FCC Part 15, Class B EN 55022 (Emissions class B) EN 55024 (Immunity)
Interchangeable blades	US, EU, KC, UK, AU, CN 

Note 1: This power supply is intended for indoor applications only.

Classification	This document is the strict property of Kerlink and shall not be either copied nor sent without express written authorization of Kerlink	
Internal Use	Kerlink m2m technologies reserved rights	
Confidential	Kerlink – 1 rue Jacqueline Auriol – 35235 THORIGNÉ-FOUILLARD	Page 26 / 100
Strict confidential		

1.4 Power consumption

The maximum power consumption is detailed hereafter:

Wirnet™ iFemtoCell	Power consumption
CPU module (20% load), Ethernet link ON	1.3W max
Wi-Fi (25%Tx,75%Rx)	0.5W max
USB WAN dongle (HSPA, 25% Tx, 75% Rx)	1W max
Radio in Rx mode (x8 demodulator on)	1.6W max

Note: The power supply of the Wirnet™ iFemtoCell must be a limited power source.

1.5 Omnidirectional LoRa antenna



Figure 8: LoRa antenna

The specifications of the omnidirectional 3dBi antenna are the following:

Classification	This document is the strict property of Kerlink and shall not be either copied nor sent without express written authorization of Kerlink	
Internal Use	Kerlink m2m technologies reserved rights	
Confidential	Kerlink – 1 rue Jacqueline Auriol – 35235 THORIGNÉ-FOUILLARD	Page 27 / 100
Strict confidential		

Item	Specification
Frequency range	862/873MHz , 902-928MHZ
Impedance	50 ohms
Technology	Dipole
VSWR	<1.7:1
Max gain	3dBi
Polarization	Vertical
Whip material	ABS
Color	White
Connector (Wirnet™ iFemtoCell 868)	SMA
Connector (Wirnet™ iFemtoCell 915 & 923)	RP-SMA
Size	135x20mm
Weight	15g
Antenna operating temperature range	-20°C to +55°C

1.5.1 Return loss

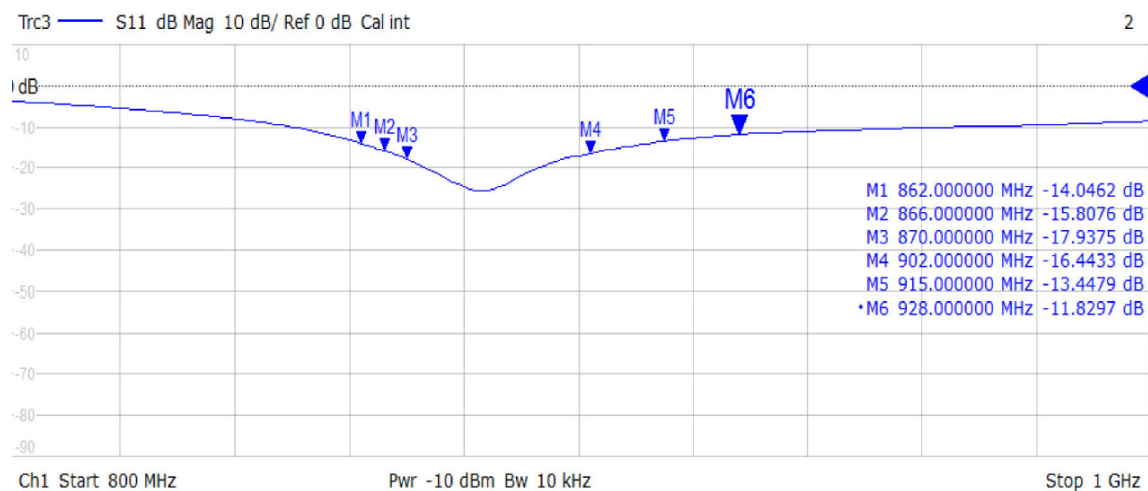

Figure 9: LoRa antenna return loss

Classification	This document is the strict property of Kerlink and shall not be either copied nor sent without express written authorization of Kerlink	
Internal Use	Kerlink m2m technologies reserved rights	
Confidential	Kerlink – 1 rue Jacqueline Auriol – 35235 THORIGNÉ-FOUILLARD	Page 28 / 100
Strict confidential		

1.5.2 Radiation patterns

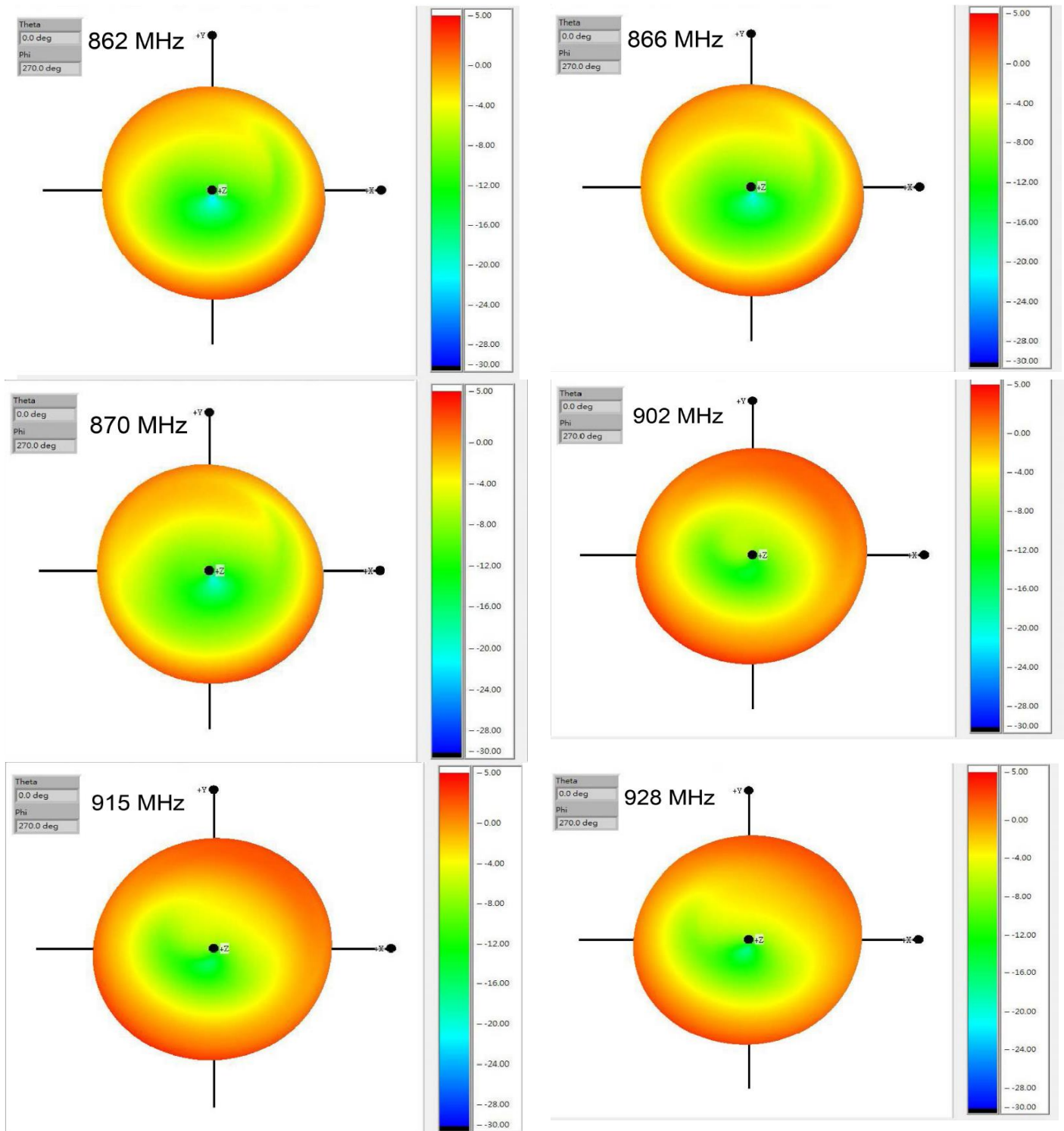

Figure 10: LoRa antenna radiation patterns

Classification	This document is the strict property of Kerlink and shall not be either copied nor sent without express written authorization of Kerlink	
Internal Use	Kerlink m2m technologies reserved rights	
Confidential	Kerlink – 1 rue Jacqueline Auriol – 35235 THORIGNÉ-FOUILLARD	Page 29 / 100
Strict confidential		

1.6 Internal Wi-Fi antenna

The specifications of the omnidirectional 3dBi antenna are the following:

Item	Specification
Frequency range	2400-2483.5MHz
Impedance	50 ohms
Technology	Ceramic chip antenna
VSWR	<2.3:1
Max gain	3dBi
Antenna operating temperature range	-20°C to +55°C

1.6.1 Return loss

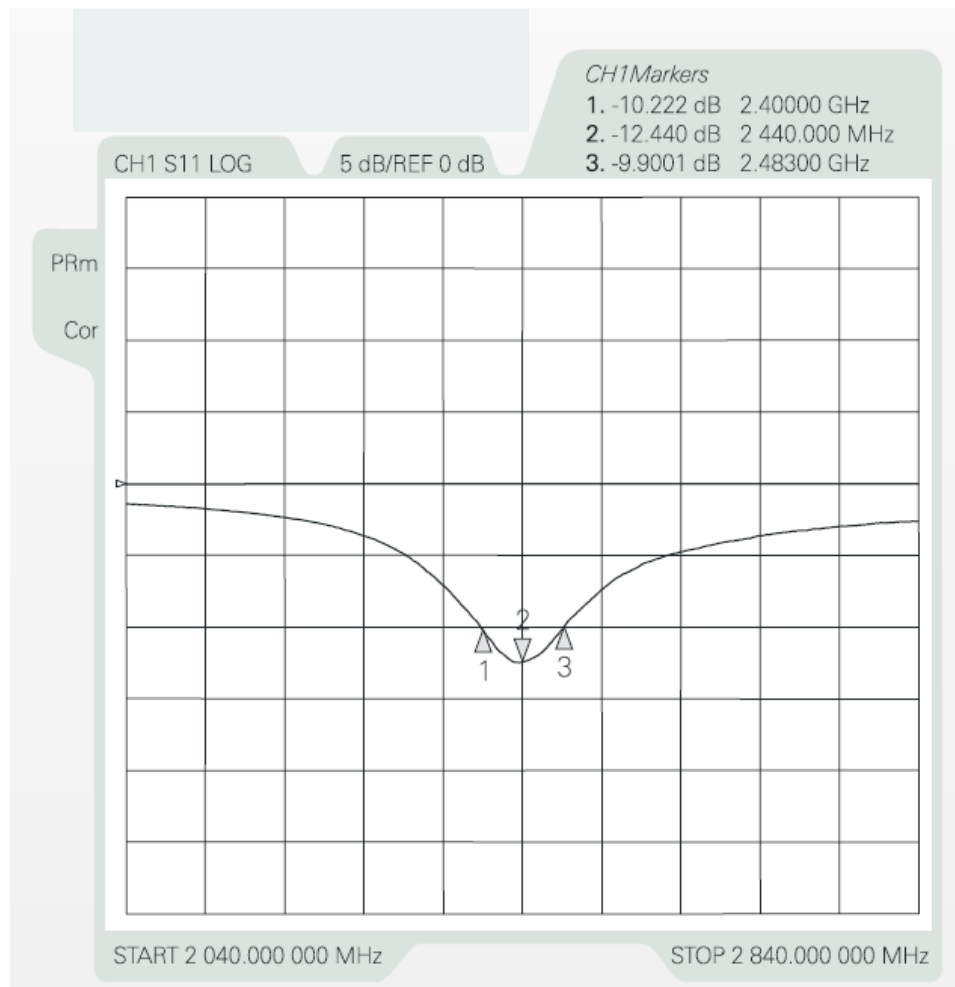

Figure 11: Wi-Fi antenna return loss

Classification	This document is the strict property of Kerlink and shall not be either copied nor sent without express written authorization of Kerlink	
Internal Use	Kerlink m2m technologies reserved rights	
Confidential	Kerlink – 1 rue Jacqueline Auriol – 35235 THORIGNÉ-FOUILLARD	Page 30 / 100
Strict confidential		

1.6.2 Radiation patterns

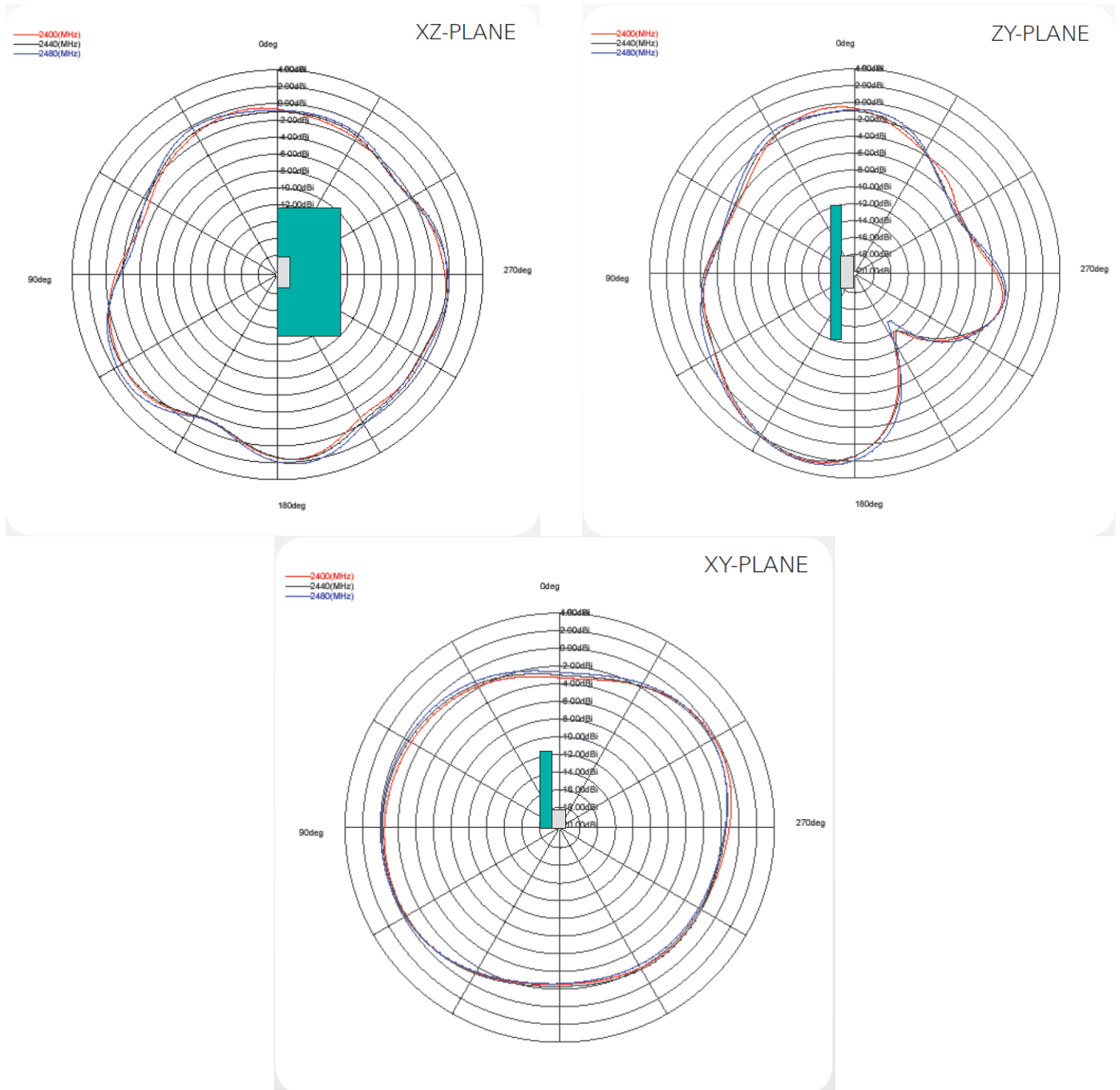

Figure 12: Wi-Fi antenna radiation patterns

Classification	This document is the strict property of Kerlink and shall not be either copied nor sent without express written authorization of Kerlink	
Internal Use	Kerlink m2m technologies reserved rights	
Confidential	Kerlink – 1 rue Jacqueline Auriol – 35235 THORIGNÉ-FOUILLARD	Page 31 / 100
Strict confidential		

1.7 LEDs description



Figure 13: LEDs

The Wirnet™ iFemtoCell owns 3 bi-color LEDs:

Item	Specification
LED 1: Power	Red blinking during the kernel boot Green blinking during system boot Green when boot is finished
LED 2: Backhaul	Red during boot Red if PacketForwarder is disconnected Green blinking during PacketForwarder connection Green fix if PacketForwarder is connected
LED 3: LoRa traffic	Red during boot PacketForwarder management Rx: green blinking Tx: red blinking

Classification	This document is the strict property of Kerlink and shall not be either copied nor sent without express written authorization of Kerlink	
Internal Use	Kerlink m2m technologies reserved rights	
Confidential	Kerlink – 1 rue Jacqueline Auriol – 35235 THORIGNÉ-FOUILLARD	Page 32 / 100
Strict confidential		

1.8 Push buttons



Figure 14: Push buttons

To press the buttons, a tool with a 1mm diameter must be used:



Figure 15: Push button tool

Classification	This document is the strict property of Kerlink and shall not be either copied nor sent without express written authorization of Kerlink	
Internal Use	Kerlink m2m technologies reserved rights	
Confidential	Kerlink – 1 rue Jacqueline Auriol – 35235 THORIGNÉ-FOUILLARD	Page 33 / 100
Strict confidential		

1.8.1 Reset push button

The reset push button must be pressed during 1s to generate a hard reset of the product.

1.8.2 WPS

Wi-Fi Protected Setup (WPS) is a standard used to establish a secure connection between equipment and a Wi-Fi access point.

The principle is to press the WPS button on the Wirnet™ iFemtoCell and on the Wi-Fi access point to get the connection.

1.9 Sticker

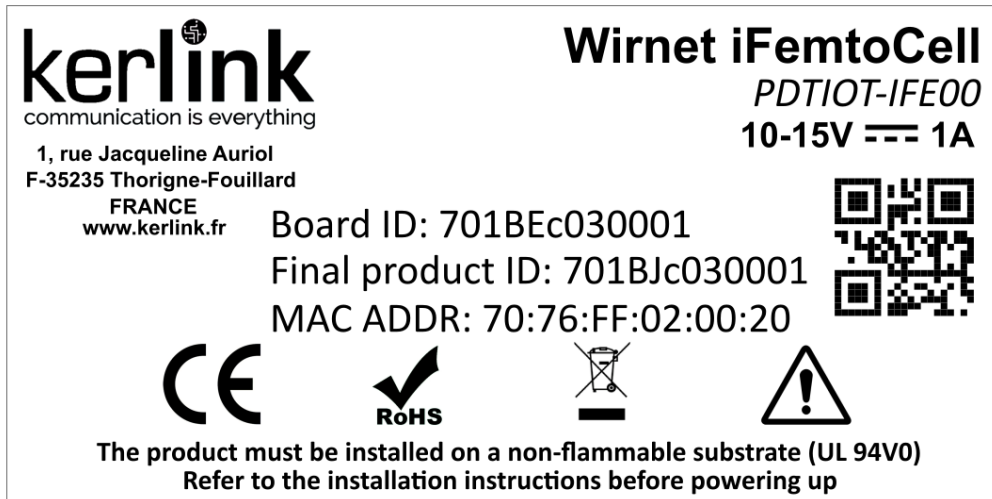

Figure 16: Sticker for WIFC 868

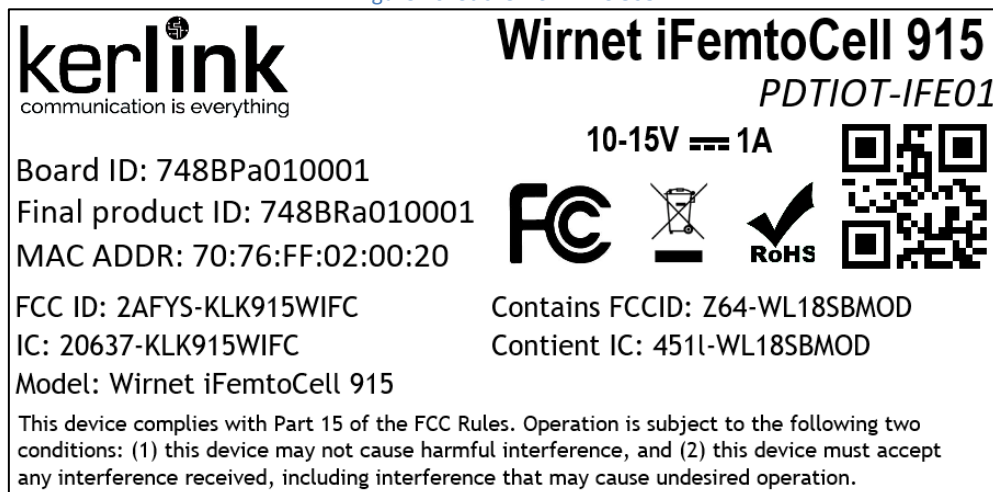

Figure 17: Sticker for WIFC 915

Classification	This document is the strict property of Kerlink and shall not be either copied nor sent without express written authorization of Kerlink	
Internal Use	Kerlink m2m technologies reserved rights	
Confidential	Kerlink – 1 rue Jacqueline Auriol – 35235 THORIGNÉ-FOUILLARD	Page 34 / 100
Strict confidential		

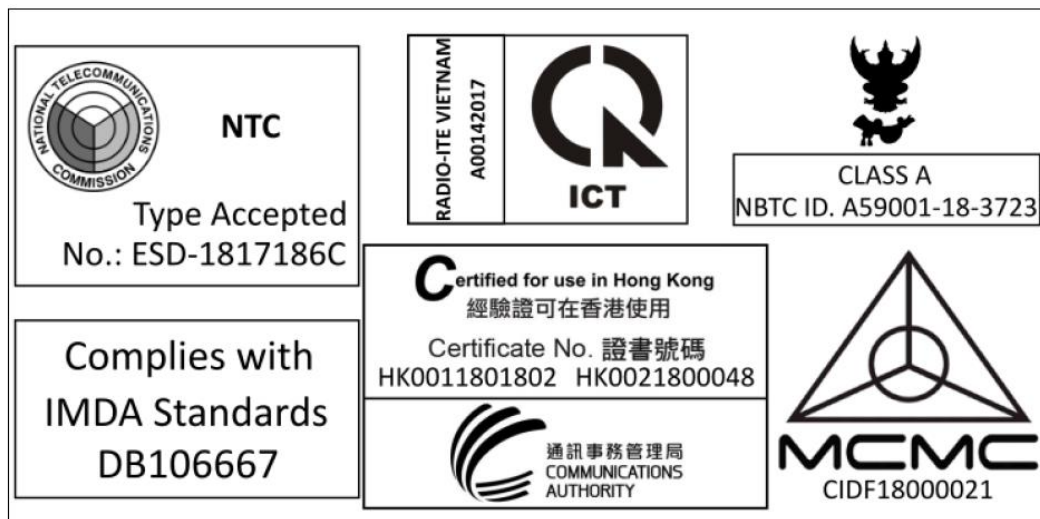
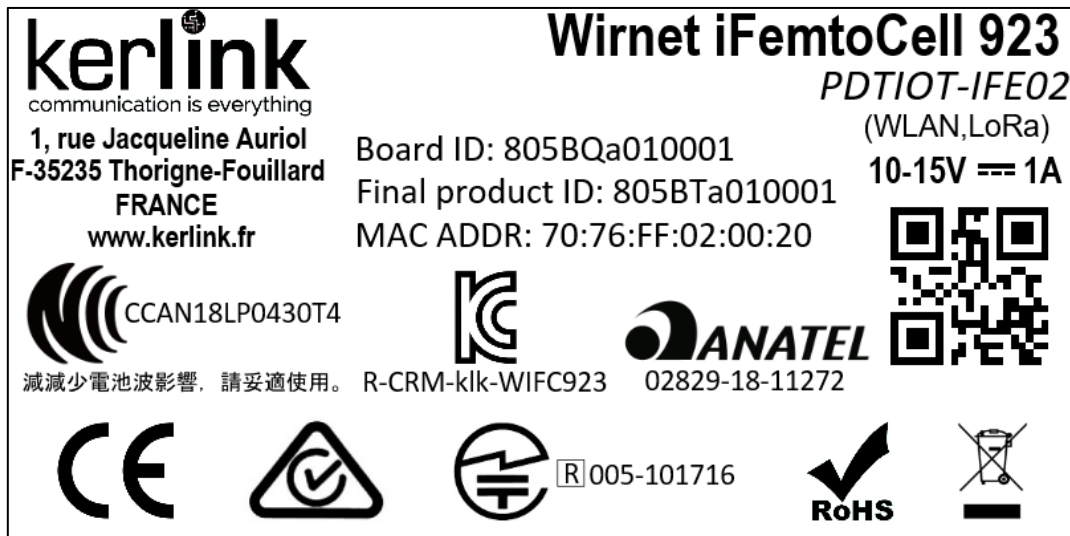

Figure 18: Sticker for WIFC 923

The Wirnet™ iFemtoCell own one sticker placed on the rear side of the casing. This sticker includes serial number, MAC address, regulatory markings and electrical information.

Classification	This document is the strict property of Kerlink and shall not be either copied nor sent without express written authorization of Kerlink	
Internal Use	Kerlink m2m technologies reserved rights	
Confidential	Kerlink – 1 rue Jacqueline Auriol – 35235 THORIGNÉ-FOUILLARD	Page 35 / 100
Strict confidential		

1.10 Wall Mounting

The Wirnet™ iFemtoCell may be mounted on a wall using the two oblong holes:



Figure 19: Wall mounting

Only two screws are needed. All needed information is mentioned on the following drawing:

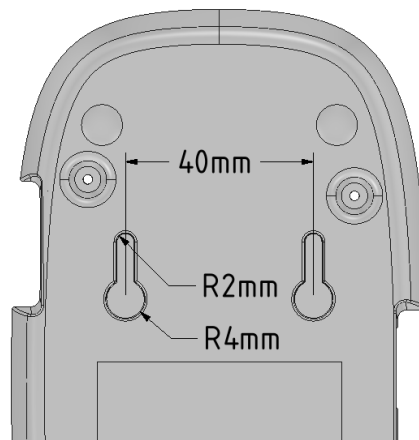

Figure 20: Wall mounting dimensions

Classification	This document is the strict property of Kerlink and shall not be either copied nor sent without express written authorization of Kerlink	
Internal Use	Kerlink m2m technologies reserved rights	
Confidential	Kerlink – 1 rue Jacqueline Auriol – 35235 THORIGNÉ-FOUILLARD	Page 36 / 100
Strict confidential		

1.11 Radio specifications

1.11.1 Main characteristics

Feature	Description
LoRa demodulator	<p>Based on SX1301 digital signal processing engine from Semtech Emulates 49 x LORA demodulators and 1 x (G)FSK demodulator per SX1301:</p> <ul style="list-style-type: none"> • 8 x LoRa demodulator at dynamic data rate with 125KHz BW • 1 x LoRa demodulator at fixed data rate • 1 x (G) FSK demodulator <p>Dynamic data-rate (DDR) adaptation Detect simultaneously 8 preambles corresponding to all data rates (Spreading Factor) at LoRa 125KHz BW 2MHz baseband BW</p>
Transceiver	<p>Based on Semtech SX1257 862MHz to 960MHz frequency range 250 kHz to 750KHz channel BW +8dBm typ. output power 10dB output power control range 128dBc/Hz Signal to Noise performance at 10MHz offset Receiver Noise Figure of 7 dB (External LNA Noise Figure of 0.7dB) -25dBm IIP3 at max gain Independent automatic gain control</p>
Sniffer	<p>Based on Semtech chipset 300MHz to 1020MHz frequency range FSK, GFSK, MSK, GMSK and OOK demodulator FSK Bit rates up to 300 kb/s Digital filtering, demodulation, AGC, AFC, synchronization and packet handling Accurate RSSI measurements through automatic gain calibration 115dB Dynamic Range RSSI +35dBm to +75dBm IIP2 depending on AGC configuration -18dBm to +20dBm IIP3 depending on AGC configuration 66 dB typ. CW interferer rejection at 1 MHz offset 79 dB typ. CW interferer rejection at 10 MHz offset</p>
External LNA	<p>Noise Figure of 0.7dB Gain 18dB at 900MHz 38dBm IIP3 at max gain</p>
External PA	<p>Maximum input power: 10dBm Maximum Output power: 27dBm Small signal gain: 32dB</p>

Classification	This document is the strict property of Kerlink and shall not be either copied nor sent without express written authorization of Kerlink	
Internal Use	Kerlink m2m technologies reserved rights	
Confidential	Kerlink – 1 rue Jacqueline Auriol – 35235 THORIGNÉ-FOUILLARD	Page 37 / 100
Strict confidential		

1.11.2 Radio front-end block diagram

The following block diagram details the architecture of the radio front-end:

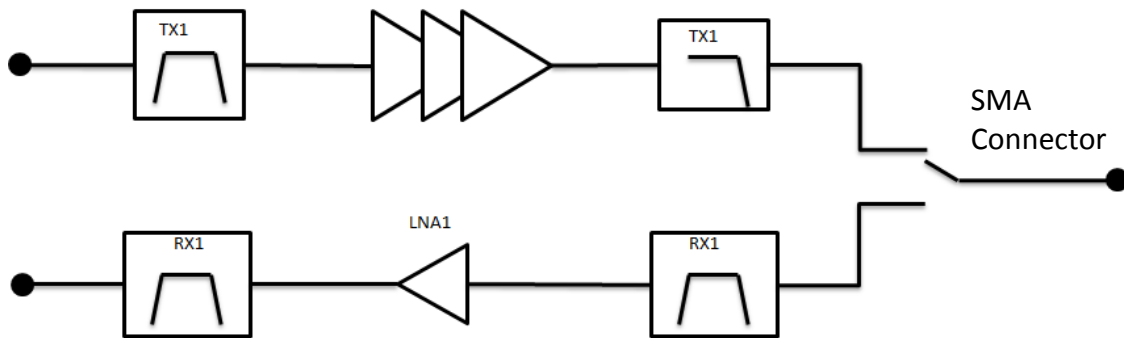

Figure 21: Front-end block diagram

The radio front-end integrates TX and RX paths. Each path is detailed hereafter:

The radio front-end is derived in three different versions to cover the unlicensed bands:

- 868MHz (863-873MHz)
- 915MHz (902-928MHz)
- 923MHz (915-928MHz)

The details of the frequency bands, channelization, out of band rejection are detailed in §1.11.4.

1.11.3 Modulations and data rates

The Wirnet™ iFemtoCell supports the following modulation schemes:

SF	BW (KHz)	Data rate (bps)
7	500	21875
8	500	12500
9	500	7031
10	500	3906
11	500	2148
12	500	1172
7	250	10938
8	250	6250
9	250	3516
10	250	1953
11	250	1074
12	250	586
7	125	5469

Classification	This document is the strict property of Kerlink and shall not be either copied nor sent without express written authorization of Kerlink	
Internal Use	Kerlink m2m technologies reserved rights	
Confidential	Kerlink – 1 rue Jacqueline Auriol – 35235 THORIGNÉ-FOUILLARD	Page 38 / 100
Strict confidential		

8	125	3125
9	125	1758
10	125	977
11	125	537
12	125	293

Note: Payload may have to be adjusted to not overrule 400ms frame length, depending on the local regulations. In this case, SF11/125KHz and SF12/125KHz are not used.

1.11.4 Frequency bands and channelization

The frequency bands covered by the Wirnet™ iFemtoCell depends on the version used (868, 915 or 923).

The downstream frequencies and upstream frequencies are listed in the following table:

Version	Link	Frequency range start/end
868	Upstream (RX Wirnet™ iFemtoCell)	863MHz / 873MHz
868	Downstream (TX Wirnet™ iFemtoCell)	863MHz / 873MHz
915	Upstream (RX Wirnet™ iFemtoCell)	902MHz / 928MHz
915	Downstream (TX Wirnet™ iFemtoCell)	902MHz / 928MHz
923	Upstream (RX Wirnet™ iFemtoCell)	915MHz / 928MHz
923	Downstream (TX Wirnet™ iFemtoCell)	915MHz / 928MHz

LoRaWAN specification defines a more accurate frequency plan and channelization, although different options could be envisaged.

The channels are summarized in the following table:

Version	Link	Channel frequency	LoRa BW (KHz)	Number of channels	Channel BW (KHz)
915	Upstream (RX Wirnet™ iFemtoCell)	902,3+i*0,2MHz (i=0 à 63)	125	64	200
915	Upstream (RX Wirnet™ iFemtoCell)	903,0+i*1.6MHz (i=0 à 7)	500	8	600
915	Downstream (TX Wirnet™ iFemtoCell)	923,3+i*0.6MHz (i=0 à 7)	500	8	600

Classification	This document is the strict property of Kerlink and shall not be either copied nor sent without express written authorization of Kerlink	
Internal Use	Kerlink m2m technologies reserved rights	
Confidential	Kerlink – 1 rue Jacqueline Auriol – 35235 THORIGNÉ-FOUILLARD	Page 39 / 100
Strict confidential		

923	Upstream (RX Wirnet™ iFemtoCell))	915,2+i*0,2MHz (i= 0 à 63)	125	64	200
923	Upstream (RX Wirnet™ iFemtoCell))	915,9+i*1.6MHz (i=0 à 7)	500	8	600
923	Downstream (TX Wirnet™ iFemtoCell))	915,2+i*0,2MHz (i= 0 à 63)	125	64	200
923	Downstream (TX Wirnet™ iFemtoCell))	920,3+i*0.6MHz (i=0 à 12)	500	13	600
868	Upstream (RX Wirnet™ iFemtoCell))	863,1+i*0,2MHz (i= 0 à 27)	125	28	200
868	Downstream (TX Wirnet™ iFemtoCell))	863,1+i*0,2MHz (i= 0 à 27)	125	28	200
868	Upstream (RX Wirnet™ iFemtoCell))	868,9+i*0,2MHz (i= 0 à 1)	125	2	200
868	Downstream (TX Wirnet™ iFemtoCell))	868,9+i*0,2MHz (i= 0 à 1)	125	2	200
868	Upstream (RX Wirnet™ iFemtoCell))	869,525MHz	125	1	250
868	Downstream (TX Wirnet™ iFemtoCell))	869,525MHz	125	1	250
868	Upstream (RX Wirnet™ iFemtoCell))	869,850MHz	125	1	300
868	Downstream (TX Wirnet™ iFemtoCell))	869,850MHz	125	1	300
868	Upstream (RX Wirnet™ iFemtoCell))	870,1+i*0,2MHz (i= 0 à 14)	125	15	200
868	Downstream (TX Wirnet™ iFemtoCell))	870,1+i*0,2MHz (i= 0 à 14)	125	15	200

Classification	This document is the strict property of Kerlink and shall not be either copied nor sent without express written authorization of Kerlink	
Internal Use	Kerlink m2m technologies reserved rights	
Confidential	Kerlink – 1 rue Jacqueline Auriol – 35235 THORIGNÉ-FOUILLARD	Page 40 / 100
Strict confidential		

Note: In South Korea, the channels defined for the “923” version must be shifted by 100KHz to meet Korean regulations i.e. 917.1MHz to 923.3MHz with 200KHz steps.

Classification	This document is the strict property of Kerlink and shall not be either copied nor sent without express written authorization of Kerlink	
Internal Use	Kerlink m2m technologies reserved rights	
Confidential	Kerlink – 1 rue Jacqueline Auriol – 35235 THORIGNÉ-FOUILLARD	Page 41 / 100
Strict confidential		

1.11.5 Output Power

The conducted output power can be adjusted from 0dBm to +27dBm.
This offers a wide range of adjustment to cover all specific countries EIRP requirements.
Antenna gain has to be considered to adjust the conducted output power to not overrule the max allowed EIRP.

Description	Specification
Conducted output power range	0dBm to +27dBm
Ripple in the band	+/- 2dB
Variation over temperature range (-20°C to +55°C)	+/- 3dB

1.11.6 Out of band emissions

Due to the very low noise transmitter, the Wirnet™ iFemtoCell is able to achieve excellent out of band emissions levels in the LTE, UMTS and GSM uplink or downlink bands.

The performances are summarized in the following table:

Version	LTE, UMTS or GSM band	Out of band emissions
868	E-GSM900 UL (880-915MHz)	-80dBm/100KHz
868	R-GSM900 UL (876-880MHz)	-60dBm/100KHz
868	LTE800 (832-860MHz)	-75dBm/100KHz
868	LTE800 (860-862MHz)	-70dBm/100KHz
915	GSM850 DL (869-894MHz)	-85dBm/100KHz
923	GSM900 UL(890-915MHz)	-85dBm/100KHz
923	GSM900 DL(935-960MHz)	-85dBm/100KHz

The performances detailed here are worst case i.e. when transmitting at maximum output power at the edge of the band.

Out of band emissions in other LTE, UMTS or GSM bands are not detailed but are obviously better.

Classification	This document is the strict property of Kerlink and shall not be either copied nor sent without express written authorization of Kerlink	
Internal Use	Kerlink m2m technologies reserved rights	
Confidential	Kerlink – 1 rue Jacqueline Auriol – 35235 THORIGNÉ-FOUILLARD	Page 42 / 100
Strict confidential		

1.11.7 Sensitivity

The sensitivity performance, depending on the version, at 10% PER, 20 bytes payload is the following:

Mode	868MHz	915MHz	923MHz
SF7/125KHz	-127dBm	-127dBm	-126dBm
SF10/125KHz	-134dBm	-134dBm	-133dBm
SF12/125KHz	-141dBm	-141dBm	-140dBm
SF7/250KHz	-125dBm	-125dBm	-124dBm
SF12/250KHz	-135dBm	-135dBm	-134dBm
SF7/500KHz	-122dBm	-122dBm	-121dBm
SF12/500KHz	-134dBm	-134dBm	-133dBm

The sensitivity may vary over the frequency band and over temperature as follows:

Description	Specification
Sensitivity variation over the band	+/- 2dB
Sensitivity variation over temperature range (-20°C to +60°C)	+/- 1dB

1.11.8 RSSI and SNR

The Wirnet™ iFemtoCell is able to receive LoRa frames from -20dBm to -141dBm, depending on the LoRa BW and SF.

The Wirnet™ iFemtoCell provides for each received frame, the RSSI and the SNR.

The RSSI is the “signal + noise” measurement of the received frame. Due to the wide spreading modulation, the LoRa receiver is able to demodulate signals below the noise floor i.e. with negative SNR.

To estimate the signal strength of the received frame, both SNR and RSSI have to be considered. As a rough estimate:

- If SNR >0, the signal strength = RSSI (dBm)
- If SNR <0, the signal strength = RSSI+SNR (dBm)

Classification	This document is the strict property of Kerlink and shall not be either copied nor sent without express written authorization of Kerlink	
Internal Use	Kerlink m2m technologies reserved rights	
Confidential	Kerlink – 1 rue Jacqueline Auriol – 35235 THORIGNÉ-FOUILLARD	Page 43 / 100
Strict confidential		

RSSI varies from -20dBm to -120dBm. -120dBm is the noise floor measured in a 200KHz BW. SNR is between 10 to 15dB for strong signals. It is close to 0dB when the signal strength approaches -120dBm. It can decrease down to -7dB or -20dB depending on the SF:

Spreading Factor	LoRa demodulator SNR
SF7	-7.5dB
SF8	-10dB
SF9	-12.5dB
SF10	-15dB
SF11	-17.5dB
SF12	-20dB

The following picture is an example of LoRa receiver characterization at SF7 / 125KHz BW. It describes the SNR, RSSI and RSSI+SNR measured vs. the signal strength:

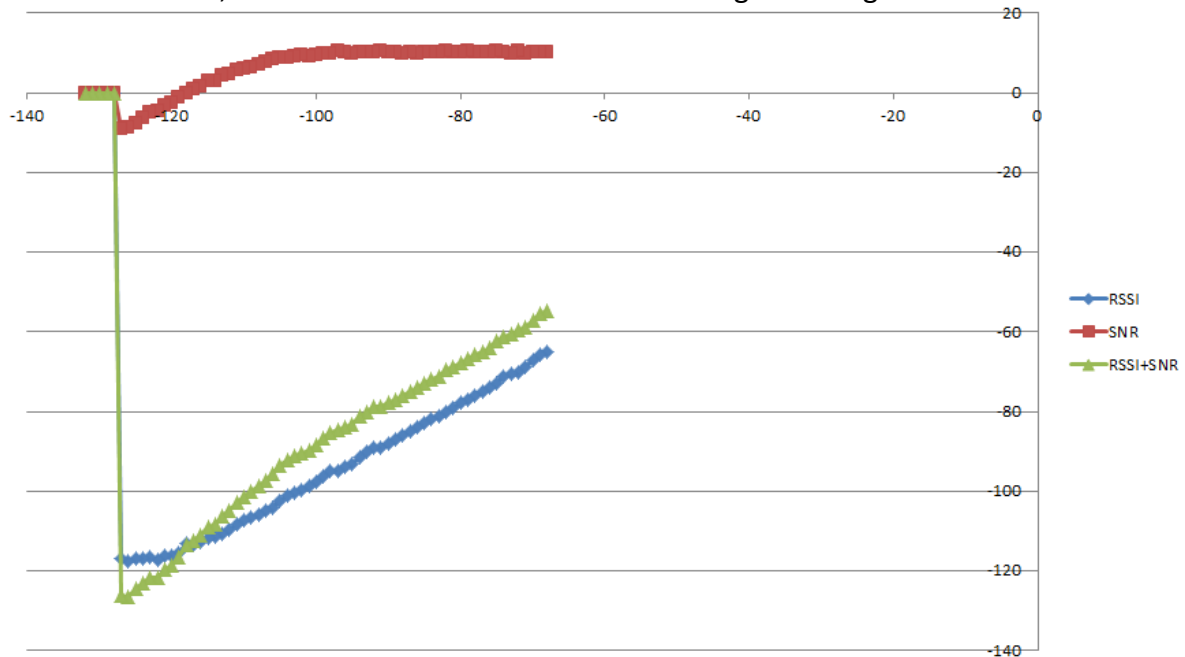

Figure 22: Example of SNR, RSSI and RSSI+SNR plots at 125KHz BW / SF7

1.11.9 Out of band blockers rejection

In the following tables, the out of band rejection is measured with a useful signal (LoRa) adjusted 3dB above the sensitivity. The blocker level (CW) is adjusted to reach 10% PER. The level of the blockers is noticed in the table and also the difference (in dB) with the useful LoRa signal.

Classification	This document is the strict property of Kerlink and shall not be either copied nor sent without express written authorization of Kerlink	
Internal Use	Kerlink m2m technologies reserved rights	
Confidential	Kerlink – 1 rue Jacqueline Auriol – 35235 THORIGNÉ-FOUILLARD	Page 44 / 100
Strict confidential		

1.11.9.1 868MHz

The useful signal is adjusted at 869.525MHz.

The blockers rejections, at different SF are the following:

Offset	SF7/125KHz	SF10/125KHz	SF12/125KHz
+2MHz	-47dBm (79dB)	-	-
-2MHz	-48dBm (78dB)	-	-
+10MHz	-15dBm (111dB)	-	-
-10MHz	-40dBm (86dB)	-	-
821MHz	-14dBm (112dB)	-	-
880MHz	-15dBm (111dB)	-	-
935MHz	-	-	-
960MHz	-	-	-

1.11.9.2 915MHz

The useful signal is adjusted at 915MHz.

The **expecting** blockers rejections, at different SF, are the following:

Offset	SF7/125KHz	SF10/125KHz	SF12/125KHz
+2MHz	-46dBm (78dB)	-46dBm (85dB)	-46dBm (92dB)
-2MHz	-44dBm (80dB)	-44dBm (87dB)	-44dBm (94dB)
+10MHz	-38dBm (86dB)	-38dBm (93dB)	-38dBm (100dB)
-10MHz	-25dBm (99dB)	-25dBm (106dB)	-25dBm (113dB)
850MHz	-12dBm (114dB)	-12dBm (118dB)	-13dBm (125dB)
894MHz	-15dBm (111dB)	-15dBm (115dB)	-15dBm (123dB)
935MHz	-15dBm (111dB)	-15dBm (115dB)	-15dBm (123dB)
960MHz	-13dBm (113dB)	-13dBm (117dB)	-13dBm (125dB)

Classification	This document is the strict property of Kerlink and shall not be either copied nor sent without express written authorization of Kerlink	
Internal Use	Kerlink m2m technologies reserved rights	
Confidential	Kerlink – 1 rue Jacqueline Auriol – 35235 THORIGNÉ-FOUILLARD	Page 45 / 100
Strict confidential		

1.11.9.3 923MHz

The useful signal is adjusted at 923MHz.

The **expecting** blockers rejections, at different SF are the following:

Offset	SF7/125KHz	SF10/125KHz	SF12/125KHz
+2MHz	-45dBm (78dB)	-	-43dBm (94dB)
-2MHz	-45dBm (78dB)	-	-40dBm (97dB)
+10MHz	-43dBm (80dB)	-	-40dBm (97dB)
-10MHz	-23dBm (100dB)	-	-34dBm (103dB)
850MHz	-	-	-
894MHz	-	-	-
910MHz	-	-	-
935MHz	-	-	-
960MHz	-	-	-

Classification	This document is the strict property of Kerlink and shall not be either copied nor sent without express written authorization of Kerlink	
Internal Use	Kerlink m2m technologies reserved rights	
Confidential	Kerlink – 1 rue Jacqueline Auriol – 35235 THORIGNÉ-FOUILLARD	Page 46 / 100
Strict confidential		

1.12 Description of the accessories

1.12.1 RJ45 cable

This cable is not provided with the Wirnet™ iFemtoCell.
It neither can be delivered as an accessory.

KERLINK recommends using a cable with the following characteristics:

Characteristics	Specification
Category	6A
Shielding	STP (U/FTP) or SSTP (S/FTP)
Section conductors	AWG26
External jacket	LSZH or PUR
Maximum length	100 meters
Operating temperature range	-20°C to +55°C

KERLINK recommends the following reference:

- TELEGARTNER AMJ 500 U/FTP 4x2x0.55 LSZH Cat. 6A IEC 600332-1

The Ethernet cable must be provided with two RJ45 T 568A (or 568B) plugs on each side:

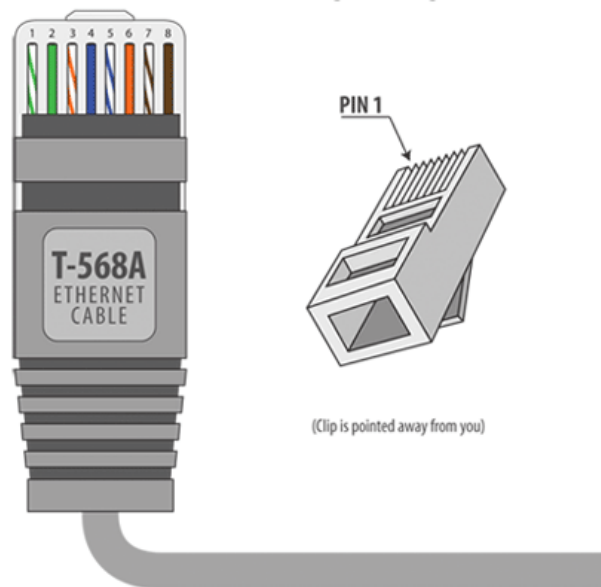

Figure 23: RJ45 T-568A plug

Classification	This document is the strict property of Kerlink and shall not be either copied nor sent without express written authorization of Kerlink	
Internal Use	Kerlink m2m technologies reserved rights	
Confidential	Kerlink – 1 rue Jacqueline Auriol – 35235 THORIGNÉ-FOUILLARD	Page 47 / 100
Strict confidential		

1.12.2 Debug tool

The Wirnet™ iFemtoCell has a proprietary serial debug interface available only inside the enclosure:

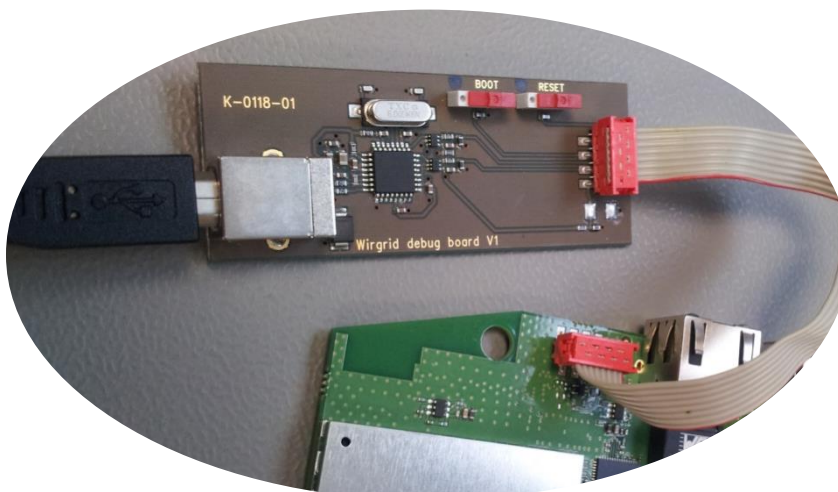

Figure 24: Debug tool connected to the Wirnet™ iFemtoCell

The Wirnet™ iFemtoCell is not warranted by KERLINK in case the enclosure is opened by customer.

Therefore, this purpose is only for specific customer needs.

This debug interface is intended to be used by authorized and qualified personnel only.

The tool is intended to be connected to the debug interface. It is mainly a simple UART to USB converter.

Classification	This document is the strict property of Kerlink and shall not be either copied nor sent without express written authorization of Kerlink	
Internal Use	Kerlink m2m technologies reserved rights	
Confidential	Kerlink – 1 rue Jacqueline Auriol – 35235 THORIGNÉ-FOUILLARD	Page 48 / 100
Strict confidential		

The main characteristics of the debug tool are:

Characteristics	Specification
UART Interface	Micromatch (TE connectivity) 3.3V internal LDO Up to 1Mb/s
USB2.0 interface	USB 2.0 A type USB Self Bus Powered at 5V Full Speed (12Mb/s)
Reset	Generate a hard reset
Boot	Select to boot mode
Operating temperature range	0°C to +60°C
Chipset	FT232BL (FTDI)

The debug tool must be used with a ribbon cable and a USB2.0 type A to type B male cable. Those cables are provided with the debug tool by KERLINK.

The USB cable must be connected to a computer where must be installed a Terminal to visualize traces.

Classification	This document is the strict property of Kerlink and shall not be either copied nor sent without express written authorization of Kerlink	
Internal Use	Kerlink m2m technologies reserved rights	
Confidential	Kerlink – 1 rue Jacqueline Auriol – 35235 THORIGNÉ-FOUILLARD	Page 49 / 100
Strict confidential		

2. Certifications

2.1 Wirnet™ iFemtoCell 868

2.1.1 Europe / CE

Wirnet™ iFemtoCell 868 complies with requirements listed in the article 3 of the RED 2014/53/EU directive from June 16th 2016:

1. Electromagnetic compatibility (article 3.1-b of the RED directive)

Applied standard(s):	EN 301 489-1	issue 2.2.0
	EN 301 489-3	issue 2.1.1
	EN 301 489-17	issue 3.2.0

2. Efficient use of the radio frequency spectrum (article 3.2 of the RED Directive)

Applied standard(s):	EN 300 328	issue 2.1.1
	EN 300 220-1	issue 3.1.1
	EN 300 220-2	issue 3.1.1

3. Safety (article 3.1-a of the RED directive)

Applied standard(s):	EN 60 950-1 (Ed. 2006+A11:2009+A1:2010+A12:2011+A2:2013)	
----------------------	--	--

4. Magnetic field exposure

Applied standard(s):	EN 62311	Ed. 2008
	EN 62479	Ed. 2010

The power supply of the Wirnet™ iFemtoCell 868 must be a limited power source.

The Wirnet™ iFemtoCell 868 is considered as a category 1.5 receiver according to the EN 300 220-1.

The Wirnet™ Femtocell 868 has CE marking.

In Europe, the Wirnet™ iFemtoCell 868 station must comply with the ERC 70-3 requirements regarding duty cycle and maximum EIRP. They are summarized in the following table:

ERC 70-03 Band	Frequency (MHz)	Power	Duty cycle
h1.2	865-868	14dBm ERP	1%
h1.4	868-868,6	14dBm ERP	1%
h1.5	868,7-869,2	14dBm ERP	0,1%
h1.6	869,4-869,65	27dBm ERP	10%
h1.7	869,7-870	14dBm ERP	1%
h2.1	870-873	14dBm ERP	1%

Classification	This document is the strict property of Kerlink and shall not be either copied nor sent without express written authorization of Kerlink	
Internal Use	Kerlink m2m technologies reserved rights	
Confidential	Kerlink – 1 rue Jacqueline Auriol – 35235 THORIGNÉ-FOUILLARD	Page 50 / 100
Strict confidential		

The frequency channels arrangement must be compliant to the LoRaWAN specification and the regional parameters (EU 863-870 MHz) as defined in [\[1\]](#) and [\[2\]](#).

If the LoRa antenna is changed, the output power must be adjusted to take into account the gain of the antenna to not overrule the ERC 70-3 regulation.

Be careful, some countries in Europe may have specific frequency range, EIRP and duty cycles regulations:

- Greece, Sweden: bands h1.2 and h2.1 must not be used
- Andorra, Austria, Belgium, Bosnia and Herzegovina, Bulgaria, Croatia, Cyprus, Czech Republic, France, Germany, Spain, Netherlands, Italy, Liechtenstein, Lithuania, Latvia, Macedonia, Malta, Montenegro, Portugal, Romania, Switzerland, Serbia, Turkey: band h2.1 must not be used

Check the local regulations before installing and commissioning the gateway.

For other countries, outside Europe, check the frequency range, the maximum EIRP and duty cycle allowed.

2.1.2 India

The Type Approvals NR-ETA 693/2017-RLO(SR) is granted by WPC to the Wirnet™ iFemtoCell 868.

However:

- Separate Import license is required to be obtained for each import as per WPC procedures,
- Record of all the equipments imported needs to be maintained and submitted to the Ministry as and when required.

In India, the Wirnet™ iFemtoCell 868 can be used with the following limitations:

Item	Specification
Frequency range	865-867MHz
Max EIRP	4W
Max conducted power with 3dBi antenna	2W
Channelization	200KHz

The frequency channels arrangement must be compliant to the LoRaWAN specification and the regional parameters (India 865-867MHz) as defined in [\[1\]](#) and [\[2\]](#).

Classification	This document is the strict property of Kerlink and shall not be either copied nor sent without express written authorization of Kerlink	
Internal Use	Kerlink m2m technologies reserved rights	
Confidential	Kerlink – 1 rue Jacqueline Auriol – 35235 THORIGNÉ-FOUILLARD	Page 51 / 100
Strict confidential		

2.1.3 South Africa

-ICASA Type approval required-

The Wirnet™ iFemtoCell 868 is compliant to:

- Radio Frequency Spectrum Regulations, 2015
- SANS 301489-1: Electromagnetic compatibility and Radio spectrum Matters (ERM) - ElectroMagnetic Compatibility (EMC) standard for radio equipment and services Part 1: Common technical requirements
- SANS 301489-3: Electromagnetic compatibility and Radio spectrum Matters (ERM); ElectroMagnetic Compatibility (EMC) standard for radio equipment and services Part 3: Specific conditions for Short-Range Devices (SRD) operating on frequencies between 9 kHz and 246 GHz
- SANS 60950-1: Information technology equipment - Safety Part 1: General requirements

In South-Africa, the Wirnet™ iFemtoCell 868 can be used with the following limitations:

Frequency (MHz)	Power	Duty cycle
868-868,6	14dBm ERP	1%
868,7-869,2	14dBm ERP	0,1%
869,4-869,65	27dBm ERP	10%
869,7-870	7dBm ERP	100%

The frequency channels arrangement is the same as in Europe i.e. must be compliant to the LoRaWAN specification and the regional parameters (EU 863-870 MHz) as defined in [\[1\]](#) and [\[2\]](#).

2.1.4 Saudi Arabia

-CITC approval required-

The Wirnet™ iFemtoCell 868 is compliant to:

- RI054 – Specifications for Non-specific Short Range Devices and Ancillary Equipment
- National Guideline for Human Exposure to Radiofrequency Electromagnetic Fields, 2009
- GEN001 – Technical Specification – General Requirements
- IEC 60950-1: 2005 + A1: 2009 + A2: 2013 - Information technology equipment - Safety - Part 1: General requirements

Classification	This document is the strict property of Kerlink and shall not be either copied nor sent without express written authorization of Kerlink	
Internal Use	Kerlink m2m technologies reserved rights	
Confidential	Kerlink – 1 rue Jacqueline Auriol – 35235 THORIGNÉ-FOUILLARD	Page 52 / 100
Strict confidential		

In Saudi-Arabia, the Wirnet™ iFemtoCell 868 can be used with the following limitations:

Frequency (MHz)	Power
865-868	14dBm ERP
868-868,6	14dBm ERP
868,7-869,2	14dBm ERP
869,4-869,65	27dBm ERP
869,7-870	7dBm ERP

The frequency channels arrangement is the same as in Europe i.e. must be compliant to the LoRaWAN specification and the regional parameters (EU 863-870 MHz) as defined in [\[1\]](#) and [\[2\]](#).

2.1.5 United Arab Emirates

-TRA Type approval required-

The Wirnet™ iFemtoCell 868 is compliant to:

- TS031 – Non Specific Short range Devices
- TS001 – EMC and Safety Requirements
- UAE.S GSO 1799: Safety Levels With Respect To Human Exposure To Radio Frequency Electromagnetic Fields, 3 kHz To 300 GHz

In United Arab Emirates, the Wirnet™ iFemtoCell 868 can be used with the following limitations:

Frequency (MHz)	Power
865-870	17dBm EIRP*
870-873	10dBm EIRP

*: can be increased to 20dBm EIRP with authorization of the TRA.

The frequency channels arrangement is the same as in Europe i.e. must be compliant to the LoRaWAN specification and the regional parameters (EU 863-870MHz) as defined in [\[1\]](#) and [\[2\]](#).

Classification	This document is the strict property of Kerlink and shall not be either copied nor sent without express written authorization of Kerlink	
Internal Use	Kerlink m2m technologies reserved rights	
Confidential	Kerlink – 1 rue Jacqueline Auriol – 35235 THORIGNÉ-FOUILLARD	Page 53 / 100
Strict confidential		

2.1.6 Russia

-Minsvyaz approval and EAC marking required



In Russia, the Wirnet™ iFemtoCell 868 can be used with the following limitations:

Frequency (MHz)	Power	Duty cycle
864-865	14dBm ERP	1%
868.7-869.2	14dBm ERP	N/A

The frequency channels arrangement is defined in the LoRaWAN specification and the regional parameters (RU 864) as defined in [\[1\]](#) and [\[2\]](#).

Classification	This document is the strict property of Kerlink and shall not be either copied nor sent without express written authorization of Kerlink	
Internal Use	Kerlink m2m technologies reserved rights	
Confidential	Kerlink – 1 rue Jacqueline Auriol – 35235 THORIGNÉ-FOUILLARD	Page 54 / 100
Strict confidential		

2.2 Wirnet™ iFemtoCell 915

The Wirnet™ iFemtoCell 915 complies to:

- IEC 60950-1:2005/A1:2009/A2:2013
- UL 60950-1: 2007, Amendment A1:2011, Amendment A2:2014
- CAN/CSA-C22.2 NO. 60950-1-07 / A1: 2011 / A2: 2014

The power supply of the Wirnet™ iFemtoCell 915 must be a limited power source.

The Wirnet™ iFemtoCell 915 complies to both FCC and IC regulations.

Applicable documents:

- CFR 47 FCC Part 15
 - FCC 47 CFR Part 15 : 2016 - Part 15- Radio frequency devices
 - FCC PART 15.247 - Operation within the bands 902–928 MHz, 2400–2483.5 MHz, and 5725–5850 MHz (frequency hopping and digitally modulated)
 - FCC Part 15.207 conducted emissions on AC mains in the band 150kHz – 30MHz
 - FCC Part 15.247 intentional radiated emissions
 - FCC Part 15.215 Additional provisions to the general radiated emissions limitations
- RSS 247
 - RSP-100 Issue 11, January 2016 - Certification of Radio Apparatus
 - RSS-Gen – Issue 4, November 2014- General requirements and Information for the Certification of radio Apparatus
 - RSS-247 Issue 1, May 2015 - Digital Transmission Systems (DTSS), Frequency Hopping Systems (FHSS) and License-Exempt Local Area Network (LE-LAN) Devices

The associated FCC and IC identifiers of the Wirnet™ iFemtoCell 915 are:

Model: WIRNET™ iFemtoCell 915

FCC ID: 2AFYS-KLK915WIFC

IC: 20637-KLK915WIFC

Some conditions have to be respected to maintain the FCC and IC compliance of the devices in USA and Canada. They are detailed in the following paragraphs.

For others countries, check the specific regulations regarding maximum EIRP and duty cycle allowed.

Classification	This document is the strict property of Kerlink and shall not be either copied nor sent without express written authorization of Kerlink	
Internal Use	Kerlink m2m technologies reserved rights	
Confidential	Kerlink – 1 rue Jacqueline Auriol – 35235 THORIGNÉ-FOUILLARD	Page 55 / 100
Strict confidential		

2.2.1 USA / FCC

As stated by the external sticker on the enclosure, “This device complies with Part 15 of the FCC Rules. Operation is subject to the following two conditions: (1) this device may not cause harmful interference, and (2) this device must accept any interference received, including interference that may cause undesired operation.”

Changes or modifications not expressly approved by the party responsible for compliance could void the user's authority to operate the equipment.

This equipment has been tested and found to comply with the limits for a Class A digital device, pursuant to part 15 of the FCC Rules. These limits are designed to provide reasonable protection against harmful interference when the equipment is operated in a commercial environment. This equipment generates, uses, and can radiate radio frequency energy and, if not installed and used in accordance with the instruction manual, may cause harmful interference to radio communications. Operation of this equipment in a residential area is likely to cause harmful interference in which case the user will be required to correct the interference at his own expense.

This device must be professionally installed.

Also, some specific recommendations for exposure to magnetic fields must be followed:

This equipment complies with FCC’s radiation exposure limits set forth for an uncontrolled environment under the following conditions:

1. This equipment should be installed and operated such that a minimum separation distance of 20 cm is maintained between the radiator (antenna) and user’s/nearby person’s body at all times.
2. This transmitter must not be co-located or operating in conjunction with any other antenna or transmitter.

2.2.2 Canada / IC

This device complies with Industry Canada’s license-exempt RSSs.

Operation is subject to the following two conditions:

1. This device may not cause harmful interference, and
2. This device must accept any interference received, including interference that may cause undesired operation of the device.

Classification	This document is the strict property of Kerlink and shall not be either copied nor sent without express written authorization of Kerlink	
Internal Use	Kerlink m2m technologies reserved rights	
Confidential	Kerlink – 1 rue Jacqueline Auriol – 35235 THORIGNÉ-FOUILLARD	Page 56 / 100
Strict confidential		

Le présent appareil est conforme aux CNR d'Industrie Canada applicables aux appareils radio exempts de licence.

L'exploitation est autorisée aux deux conditions suivantes:

- 1. L'appareil ne doit pas produire de brouillage;*
- 2. L'utilisateur de l'appareil doit accepter tout brouillage radioélectrique subi, même si le brouillage est susceptible d'en compromettre le fonctionnement.*

Under Industry Canada regulations, this radio transmitter may only operate using an antenna of a type and maximum (or lesser) gain approved for the transmitter by Industry Canada. To reduce potential radio interference to other users, that antenna type and its gain should be so chosen that the equivalent isotropically radiated power (EIRP) is not more than that necessary for successful communication.

This radio transmitter has been approved by Industry Canada to operate with the antenna types listed as accessories with the maximum permissible gain and required antenna impedance for each antenna type indicated. Antenna types not included in this list, having a gain greater than the maximum gain indicated for that type, are strictly prohibited for use with the device.

This equipment should be installed and operated such that a minimum separation distance of 20 cm is maintained between the radiator (antenna) and user's/nearby person's body at all times.

The radio transmitter has been approved by Industry Canada to operate with a maximum duty cycle of 40% to not overrule the 2.784 W/m² RF Field Strength Limits for Devices. The duty cycle, in normal conditions, is far below this limit. Do not operate the Wirnet™ iFemtoCell 915 out of the 40% duty cycle limit.

Classification	This document is the strict property of Kerlink and shall not be either copied nor sent without express written authorization of Kerlink	
Internal Use	Kerlink m2m technologies reserved rights	
Confidential	Kerlink – 1 rue Jacqueline Auriol – 35235 THORIGNÉ-FOUILLARD	Page 57 / 100
Strict confidential		

2.3 Wirnet™ iFemtoCell 923

The Wirnet™ iFemtoCell 923 is compliant to:

- IEC 60950-1:2005/A1:2009/A2:2013
- CENELEC EN 60 950-1 (Ed. 2006/A11: 2009/A1: 2010/A12:2011/A2:2013)
- AS/NZS 60950.1: 2011
- GB4943-2011
- K60950-1
- J60950-1

The Wirnet™ iFemtoCell 923 is also compliant to both FCC and CE regulations.

Applicable documents:

- CFR 47 FCC Part 15:
 - FCC 47 CFR Part 15: 2016 - Part 15- Radio frequency devices
 - FCC PART 15.247 - Operation within the bands 902–928 MHz, 2400–2483.5 MHz, and 5725–5850 MHz (frequency hopping and digitally modulated)
 - FCC Part 15.207 conducted emissions on AC mains in the band 150kHz – 30MHz
 - FCC Part 15.247 intentional radiated emissions
- Article 3.2 of the RED Directive :
Applied standard(s):
 - EN 300 220-1, V3.1.1
 - EN 300 220-2, V3.1.1
 - EN 300 328, issue 2.1.1

The Wirnet™ iFemtoCell 923 is considered as a category 1.5 receiver according to the EN 300 220-1.

Note 1:

The power supply of the Wirnet™ iFemtoCell 923 must be a limited power source.

Note 2:

Depending on the countries, check the specific regulations applying, especially regarding frequency range, maximum EIRP, duty cycle allowed, maximum transmit duration, carrier sense mandatory or not...

Some specific rules are detailed hereafter for specific countries.

Classification	This document is the strict property of Kerlink and shall not be either copied nor sent without express written authorization of Kerlink	
Internal Use	Kerlink m2m technologies reserved rights	
Confidential	Kerlink – 1 rue Jacqueline Auriol – 35235 THORIGNÉ-FOUILLARD	Page 58 / 100
Strict confidential		

2.3.1 Australia

M2M Connectivity is the only Responsible Supplier of the Wirnet™ iFemtoCell 923 under the ACMA registration process. The company acts as importer of the Wirnet™ iFemtoCell 923 and agreed to let Kerlink affix the product with the RCM mark.

The following label is placed on the outside part of the enclosure:



The WIFC 923 must comply with the requirements of the relevant ACMA Standards made under the Radiocommunications Act 1992 and the Telecommunications Act 1997. These Standards are referenced in notices made under section 182 of the Radiocommunications Act and 407 of the Telecommunications Act.

The applicable Standard for LoRa is “Radiocommunications (Short Range Devices) Standard, AS/NZS 4268: 2017: Radio equipment and systems – Short range devices – Limits and methods of measurement”.

In Australia, the Wirnet™ iFemtoCell 923 can be used with the following limitations:

Item	Specification
Frequency range	915-928MHz
Max EIRP	1W (30dBm)
Max conducted power with 3dBi antenna	27dBm

The frequency channels arrangement must be compliant to the LoRaWAN specification and the regional parameters (AU 915-928MHz or AS923) as defined in [\[1\]](#) and [\[2\]](#).

Its usage summarized hereafter:

Classification	This document is the strict property of Kerlink and shall not be either copied nor sent without express written authorization of Kerlink	
Internal Use	Kerlink m2m technologies reserved rights	
Confidential	Kerlink – 1 rue Jacqueline Auriol – 35235 THORIGNÉ-FOUILLARD	Page 59 / 100
Strict confidential		

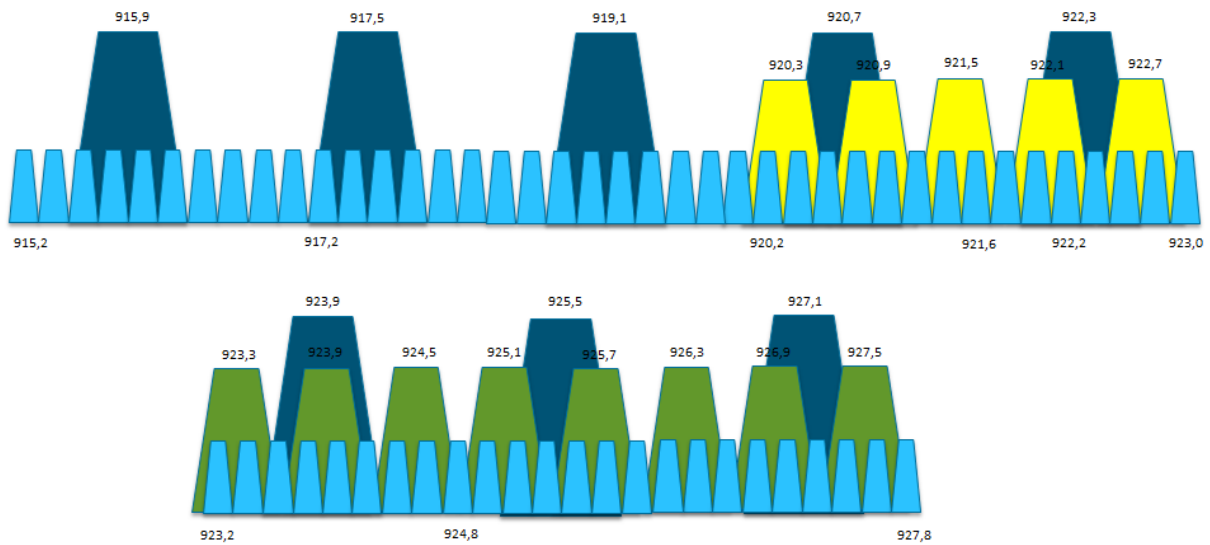

Figure 25: Channels allocation in Australia

Note:

In the above figure:

- Upstream channels in blue:
 - 64 channels from 915.2 MHz to 927.8 MHz by steps of 200 kHz, 125 kHz BW LoRa modulation, SF7 to SF10 to meet 400ms maximum frame length
 - 8 channels from 915.9 MHz to 927.1 MHz by steps of 1.6 MHz, with 500 kHz BW LoRa modulation, SF7 to SF12
- Downstream channels in green:
 - 8 channels from 923.3 MHz to 927.5 MHz by steps of 600 kHz, with 500 kHz BW LoRa modulation, SF7 to SF12
- Unused channels are in yellow

Classification	This document is the strict property of Kerlink and shall not be either copied nor sent without express written authorization of Kerlink	
Internal Use	Kerlink m2m technologies reserved rights	
Confidential	Kerlink – 1 rue Jacqueline Auriol – 35235 THORIGNÉ-FOUILLARD	Page 60 / 100
Strict confidential		

2.3.2 New-Zealand

Due to mutual Recognition with Australia, the Wirnet™ iFemtoCell 923 is exempted from the requirement to be the subject of a New Zealand declaration of conformity and to comply with New Zealand labelling requirements, provided the product is declared, labelled and supplied in accordance with the Radiocommunications (Compliance Labelling) Notice 2003, or a notice in replacement thereof, issued by the ACMA under section 182 of the Radiocommunications Act 1992 (Australia). See §**Erreur ! Source du renvoi introuvable.**

The Wirnet™ iFemtoCell 923 is compliant to General User Radio License (GURL) for Short Range Devices (SRD) and all the applicable deviations such as item 23:

Transmissions must not exceed the following unwanted emission limits: –79 dBW (–49 dBm) e.i.r.p. within 800 – 915 MHz and –63 dBW (–33 dBm) e.i.r.p. within 928 MHz – 1 GHz. The reference bandwidth for emissions is 100 kHz. Outside the band 800 MHz – 1 GHz, the limits prescribed in applicable standards prescribed in the Radiocommunications (Radio Standards) Notice 2016 apply. In the absence of applicable standards, the limits prescribed in Table 2 of the notice apply.*

In New-Zealand, the WIFC 923 can be used with the following limitations:

Item	Specification
Frequency range	920-928 MHz
Max EIRP	4W (36dBm)
Max conducted power with 3dBi antenna	33dBm
Upstream channels	8 channels 915.9 MHz to 927.1 MHz Steps of 1.6 MHz 500 kHz BW LoRa modulation SF7 to SF12
Upstream channels	64 channels 915.2 MHz to 927.8 MHz Steps of 200 kHz 125 kHz BW LoRa modulation SF7 to SF12
Downstream channels	8 channels 923.3 MHz to 927.5 MHz Steps of 600 kHz 500 kHz BW LoRa modulation SF7 to SF12

Classification	This document is the strict property of Kerlink and shall not be either copied nor sent without express written authorization of Kerlink	
Internal Use	Kerlink m2m technologies reserved rights	
Confidential	Kerlink – 1 rue Jacqueline Auriol – 35235 THORIGNÉ-FOUILLARD	Page 61 / 100
Strict confidential		

Or:

Item	Specification
Frequency range	915-928 MHz
Max EIRP	1W (30dBm)
Max conducted power with 3dBi antenna	27dBm
Upstream channels	64 channels 915.2 MHz to 927.8 MHz Steps of 200 kHz 125 kHz BW LoRa modulation SF7 to SF12
Downstream channels	64 channels 915.2 MHz to 927.8 MHz Steps of 200 kHz 125 kHz BW LoRa modulation SF7 to SF12

Therefore, two different frequency plans can be used:

- frequency plan and channel arrangement similar to Australia, according to the LoRaWAN specification and the regional parameters (AU 915-928MHz) as defined in [1] and [2].
- frequency plan compliant to the LoRaWAN specification and the regional parameters (AS 923MHz) as defined in [1] and [2].

- Upstream and Downstream channels are in blue (64)
- Unused channels are in yellow

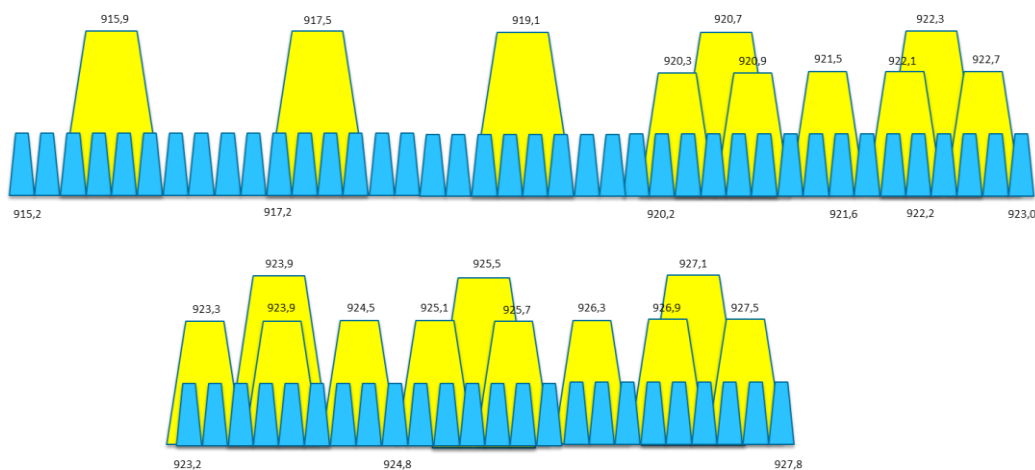

Figure 26: Channels allocation in New-Zealand - Second configuration

Classification	This document is the strict property of Kerlink and shall not be either copied nor sent without express written authorization of Kerlink	
Internal Use	Kerlink m2m technologies reserved rights	
Confidential	Kerlink – 1 rue Jacqueline Auriol – 35235 THORIGNÉ-FOUILLARD	Page 62 / 100
Strict confidential		

2.3.3 Japan

The Wirnet™ iFemtoCell 923 is certified by C&S in Japan and registered with number **005-101716**.

The specified Radio Equipment marking is visible on the external sticker on the enclosure:

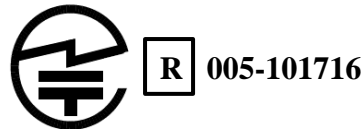

The Wirnet™ iFemtoCell 923 is compliant to “ARIB STD-T108 - 920MHz-Band Telemeter, Telecontrol and Data Transmission Radio Equipment”.

The certification is valid for 3dBi referenced antennas from KERLINK.

Contact Kerlink for more information.

In Japan, the Wirnet™ iFemtoCell 923 can be used with the following limitations:

Item	Specification
Frequency range	920.5-928.0MHz
Channelization	200KHz
Max EIRP (920.6-923.4MHz)*	500mW (27dBm)
Max conducted power (920.6-923.4MHz)*	250mW (24dBm)
Max EIRP (923.6-928MHz)**	40mW (16dBm)
Max conducted power (923.6-928.0MHz)**	20mW (13dBm)
Carrier sense (LBT) 920.6-922.2MHz*	5ms / -80dBm
Carrier sense (LBT) 922.4-923.4MHz*	128uS / -80dBm
Carrier sense (LBT) 923.6-928.0MHz**	128uS / -80dBm
Transmit duration (920.6-922.2MHz)*	< 4s
Transmit duration (922.4-923.4MHz)*	<400ms
Transmit duration (923.6-928.0MHz)**	<400ms
Pause duration (920.4-922.2MHz)	> 50 ms
Pause duration (922.4-923.4MHz)	> 10*Tx duration
Pause duration (923.6-928.0MHz)	> 10*Tx duration

*: ARIB STD-T108 Convenience Radio Station

** : ARIB STD-T108 Specified low power radio station

The frequency plan and channel allocation is defined for Japan in the LoRaWAN specification and the regional parameters as defined in [\[1\]](#) and [\[2\]](#), according to “AS 923MHz” plan.

The full frequency plan proposed by Kerlink is the following:

Classification	This document is the strict property of Kerlink and shall not be either copied nor sent without express written authorization of Kerlink	
Internal Use	Kerlink m2m technologies reserved rights	
Confidential	Kerlink – 1 rue Jacqueline Auriol – 35235 THORIGNÉ-FOUILLARD	Page 63 / 100
Strict confidential		

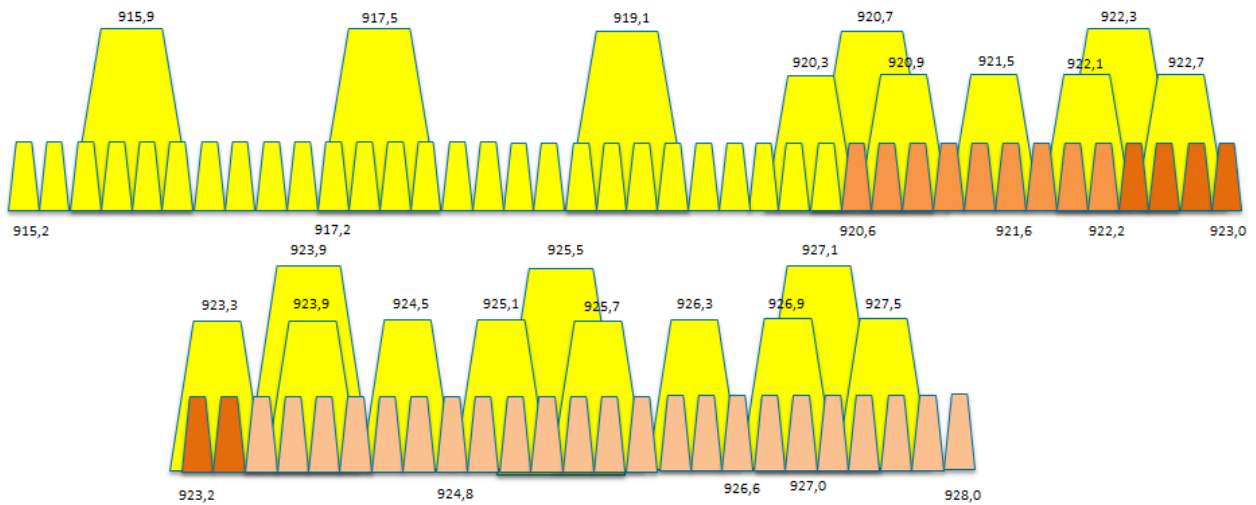

Figure 27 : Channels allocation proposal in Japan

Note:

In the above figure:

- Upstream and downstream channels are in orange: 38 channels, 200KHz spacing, 125KHz BW
- Upstream channels in medium orange:
 - 9 channels (920.6MHz to 922.2MHz)
 - SF7 to SF12
 - Max frame length=4s
 - 50 ms between frames
 - 500mW EIRP
 - 5ms min carrier sense
- Upstream channels in dark orange:
 - 6 channels (922.4MHz to 923.4MHz)
 - SF7 to SF10
 - Max frame length=400ms
 - 10% duty cycle max
 - 500mW EIRP
 - 128us min carrier sense
- Upstream channels in light orange:
 - 23 channels (923.6MHz to 928.0MHz)
 - SF7 to SF10
 - Max frame length=400ms
 - 10% duty cycle max
 - 40mW EIRP
 - 128us min carrier sense
- Unused channels are in yellow

The channels allocation can be organized differently if needed.

Classification	This document is the strict property of Kerlink and shall not be either copied nor sent without express written authorization of Kerlink	
Internal Use	Kerlink m2m technologies reserved rights	
Confidential	Kerlink – 1 rue Jacqueline Auriol – 35235 THORIGNÉ-FOUILLARD	Page 64 / 100
Strict confidential		

2.3.4 Taiwan

The Wirnet™ iFemtoCell 923 is NCC certified. The certification number is:



In Taiwan, the Wirnet™ iFemtoCell 923 can be used as a « digitally modulated techniques systems” according to item 1, chapter 4.8.1 of the “Low Power 0002 (LP0002)” specifications.

Item	Specification
Frequency range	920-925MHz
Max EIRP	0.5W
Max conducted power with 3dBi antenna	250mW (24dBm)

For Reducing RF Influence, Use Properly.

低功率電波輻射性電機管理辦法

第十二條經型式認證合格之低功率射頻電機，非經許可，公司、商號或使用者均不得擅自變更頻率、加大功率或變更原設計之特性及功能。

第十四條低功率射頻電機之使用不得影響飛航安全及干擾合法通信；經發現有干擾現象時，應立即停用，並改善至無干擾時方得繼續使用。

前項合法通信，指依電信法規定作業之無線電通信。

低功率射頻電機須忍受合法通信或工業、科學及醫療用電波輻射性電機設備之干擾。

The Wirnet™ iFemtoCell 923 is also compliant to:

- CNS 13438: 2006 - Information technology equipment – Radio disturbance Characteristics – limits and methods of measurement.
- CNS 14336-1: 2010 - Information Technology Equipment – Safety – Part 1: General requirements.

Classification	This document is the strict property of Kerlink and shall not be either copied nor sent without express written authorization of Kerlink	
Internal Use	Kerlink m2m technologies reserved rights	
Confidential	Kerlink – 1 rue Jacqueline Auriol – 35235 THORIGNÉ-FOUILLARD	Page 65 / 100
Strict confidential		

The LoRa frequency plan and channel allocation for Taiwan is defined in the LoRaWAN specification and the regional parameters, as defined in [1] and [2], according to “AS 923MHz”. However, this plan cannot be used due to LoRa BW limitation (only 500KHz BW can be envisaged).

Therefore, KERLINK recommends the following allocation:

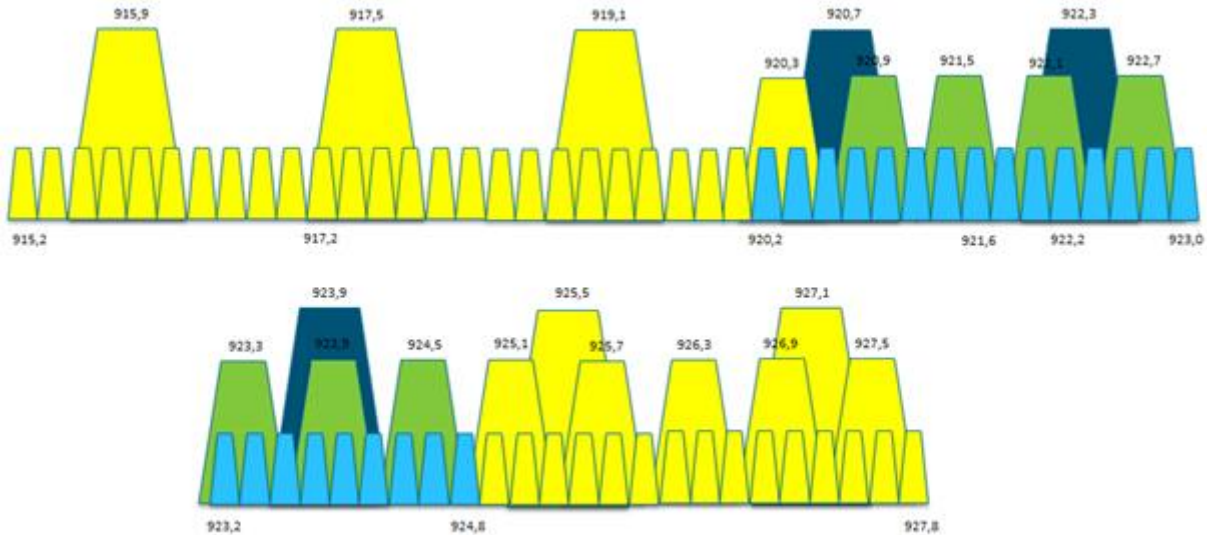

Figure 28 : Channels allocation proposal in Taiwan

Note:

In the above figure:

- Upstream channels are in blue (24 channels with 125 kHz BW LoRa modulation, SF7 to SF10, from 920.2 MHz to 924.8 MHz by steps of 200 kHz and 3 channels with 500 kHz BW LoRa modulation, SF7 to SF12, from 920.7 MHz to 923.9 MHz by steps of 1.6 MHz)
- Downstream channels are in green (7 channels with 500 kHz BW LoRa modulation, SF7 to SF12, from 920.9 MHz to 924.5 MHz by steps of 600 kHz)
- Unused channels are in yellow

The channels allocation can be organized differently if needed.

Classification	This document is the strict property of Kerlink and shall not be either copied nor sent without express written authorization of Kerlink	
Internal Use	Kerlink m2m technologies reserved rights	
Confidential	Kerlink – 1 rue Jacqueline Auriol – 35235 THORIGNÉ-FOUILLARD	Page 66 / 100
Strict confidential		

2.3.5 Hong Kong

The WIFC 923 must be certified in Hong-Kong, based on a “Voluntary Certification Scheme”. It must be compliant to “HKTA 1035– Issue7, 2016 Performance specification for radio equipment exempted from licensing” and “HKCA 1078 – Issue 1, 2017, Performance Specification for Radio Equipment Operating in the 920 – 925 MHz Band for the Provision of Public Telecommunications Services” is under approval process within OFCA. This document may be released soon and may be applicable to the WIFC 923.

The following label is placed on the outside part of the enclosure:



In Hong-Kong, the Wirnet™ iFemtoCell 923 can be then used with the following limitations:

Item	Specification
Frequency range	920-925MHz
Max EIRP	36dBm (4W)
Max conducted power with 3dBi antenna	33dBm
Channelization	200KHz
Number of channels	24
Channels center frequency	920.2 MHz +n*0.2MHz (0<=n<=23)

The frequency channels arrangement may be compliant to the LoRaWAN specification and the regional parameters (AS 923MHz) as defined in [\[1\]](#) and [\[2\]](#), although Hong-Kong is not listed in the applied countries.

KERLINK recommends the following allocation:

Classification	This document is the strict property of Kerlink and shall not be either copied nor sent without express written authorization of Kerlink	
Internal Use	Kerlink m2m technologies reserved rights	
Confidential	Kerlink – 1 rue Jacqueline Auriol – 35235 THORIGNÉ-FOUILLARD	Page 67 / 100
Strict confidential		

- Upstream and Downstream channels are in orange (24 channels)
- Unused channels are in yellow

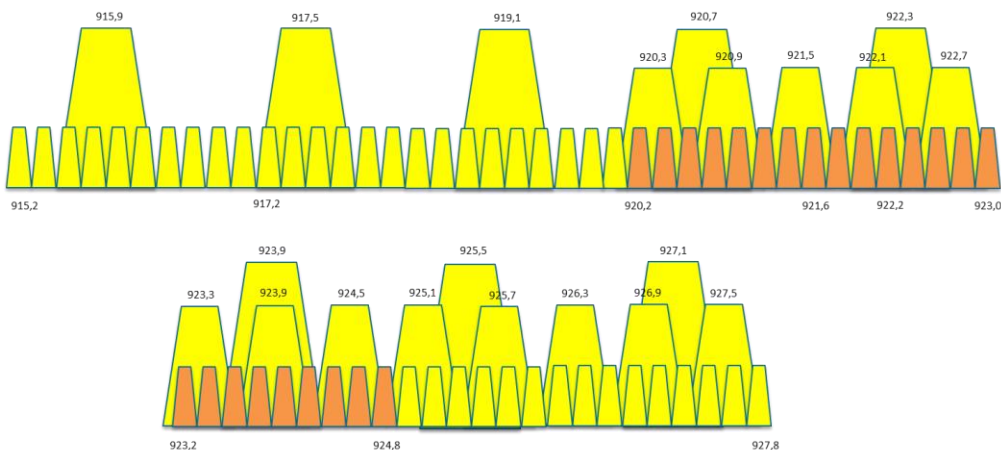

Figure 29: Channels allocation in Hong Kong

The WIFC 923 is used in the following configuration:

- Upstream / downstream channels are in orange:
 - 24 channels from 920.2 MHz to 924.8 MHz by steps of 200 kHz 125 kHz BW LoRa modulation SF7 to SF12
- Unused channels are in yellow

2.3.6 Singapore

The WIFC 923 must be compliant to “IMDA Technical Specifications for Short Range Devices (IMDA TS SRD) – Issue 1, October 2016”. A dealer license is required to operate the Wirnet™ iFemtoCell 923 in Singapore. The expiry date is 31/12/2022.

The following label is placed on the outside part of the enclosure:

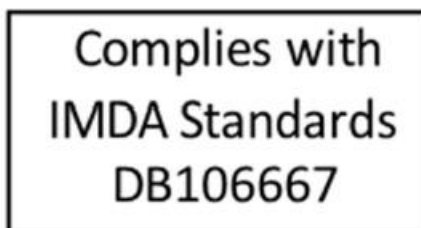

Classification	This document is the strict property of Kerlink and shall not be either copied nor sent without express written authorization of Kerlink	
Internal Use	Kerlink m2m technologies reserved rights	
Confidential	Kerlink – 1 rue Jacqueline Auriol – 35235 THORIGNÉ-FOUILLARD	Page 68 / 100
Strict confidential		

In Singapore, the Wirnet™ iFemtoCell 923 can be used with the following limitations:

Item	Specification
Frequency range	920-925MHz
Max ERP	500mW
Max EIRP	29dBm
Max conducted power with 3dBi antenna	26dBm

The frequency channels arrangement may be compliant to the LoRaWAN specification and the regional parameters (AS 923MHz) as defined in [1] and [2].

KERLINK recommends the following allocation:

- Upstream and Downstream channels are in orange (24 channels)
- Unused channels are in yellow

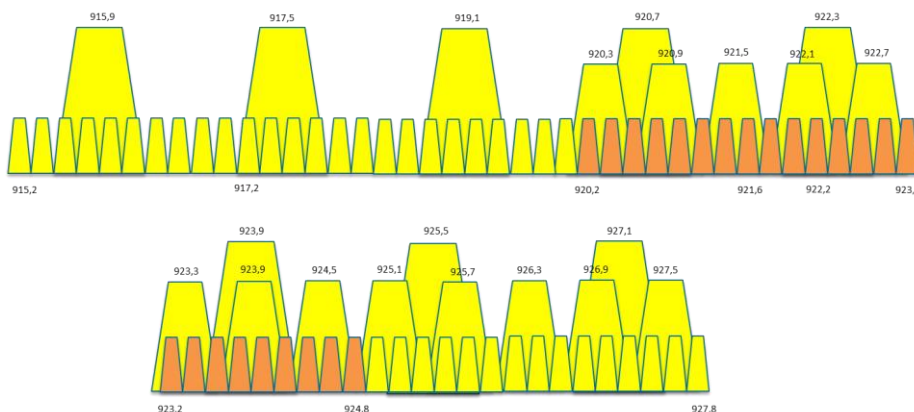

Figure 30: Channels allocation in Singapore

Note 1:

In the above figure:

- Upstream / downstream channels are in orange:
 - 24 channels from 920.2 MHz to 924.8 MHz by steps of 200 kHz
 - 125 kHz BW LoRa modulation
 - SF7 to SF12
- Unused channels are in yellow

2.3.7 Thailand

The WIFC 923 had to be compliant to “Technical Standard for non-RFID Radio Communication Equipment 920-925 MHz - NBTC TS 1033-2560”, NTC TS 5001-2550, Radiocommunication Equipment (Radio Frequency Radiation Exposure in 9 kHz-300 GHz)

The following label is placed on the outside part of the enclosure:



CLASS A
NTC ID. A59001-18-3723

In Thailand, the Wirnet™ iFemtoCell 923 can be used with the following limitations:

Item	Specification
Frequency range	920-925MHz
Max EIRP	500mW (27dBm)
Max conducted power with 3dBi antenna	24dBm
Duty cycle	<10%
Channelization	200KHz
Number of channels	24
Channels center frequency	920.2 MHz +n*0.2MHz (0<=n<=23)

The frequency channels arrangement may be compliant to the LoRaWAN specification and the regional parameters (AS 923MHz) as defined in [\[1\]](#) and [\[2\]](#).

KERLINK recommends the following allocation:

Classification	This document is the strict property of Kerlink and shall not be either copied nor sent without express written authorization of Kerlink	
Internal Use	Kerlink m2m technologies reserved rights	
Confidential	Kerlink – 1 rue Jacqueline Auriol – 35235 THORIGNÉ-FOUILLARD	Page 70 / 100
Strict confidential		

- Upstream and Downstream channels are in orange (24 channels)
- Unused channels are in yellow

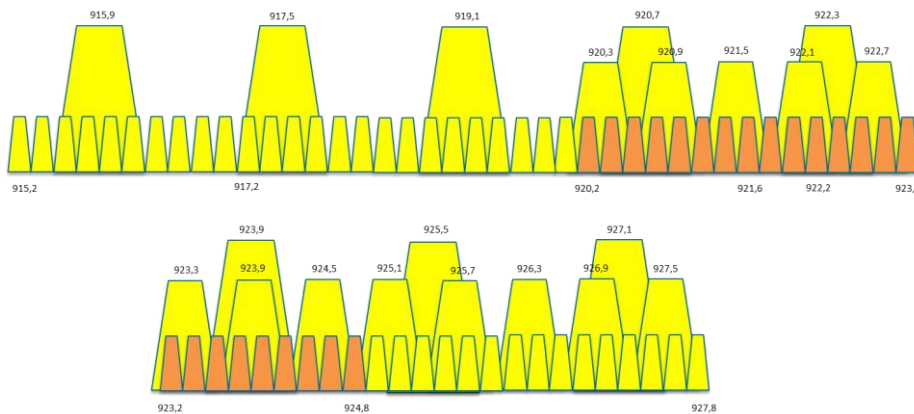

Figure 31: Channels allocation in Thailand

Note 1:

In the above figure:

- Upstream / downstream channels are in orange:
 - 24 channels from 920.2 MHz to 924.8 MHz by steps of 200 kHz
 - 125 kHz BW LoRa modulation
 - SF7 to SF12
- Unused channels are in yellow

2.3.8 South Korea

The WIFC 923 is compliant to:

- Article 30 (Radio Equipment such as RFID / USN) (1) Technology of radio equipment for RFID using radio waves in the 917~923.5 Mhz frequency band
- Clause 2, Article 58-2 of Radio Waves Act
- Regulations on Radio Equipment (Enforcement Decree of MSIT NO. 1, Jul 26, 2017)
- Unlicensed Radio Equipment Established Without Notice (MSIT Public Notification 2017-10, Sep 1, 2017)
- Technical Requirements of Radio Wave Application (RRA Public Notification 2016-20, Sep 27, 2016)

The certification is valid for indoor usage only.

Classification	This document is the strict property of Kerlink and shall not be either copied nor sent without express written authorization of Kerlink	
Internal Use	Kerlink m2m technologies reserved rights	
Confidential	Kerlink – 1 rue Jacqueline Auriol – 35235 THORIGNÉ-FOUILLARD	Page 71 / 100
Strict confidential		

The following label is placed on the outside part of the enclosure:



Figure 32: KC minimum label

The full label is as follows:

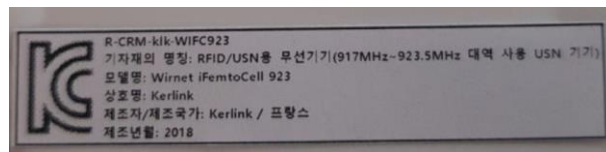

Figure 33: KC full label

In Republic of Korea, the Wirnet™ iFemtoCell 923 can be used with the following limitations:

Item	Specification	
Frequency range	920,9-921.9MHz	922,1-923.3MHz
Max EIRP	10mW (10dBm)	25mW (14dBm)
Carrier sense (LBT)	5ms / -65dBm	
Transmit duration	< 4s	
Pause duration	> 50 ms	
Duty cycle	<2% in 20 s duration	

The frequency channels arrangement must be compliant to the LoRaWAN specification and the regional parameters (KR 920-923MHz) as defined in [\[1\]](#) and [\[2\]](#).

KERLINK recommends the following allocation:

Classification	This document is the strict property of Kerlink and shall not be either copied nor sent without express written authorization of Kerlink	
Internal Use	Kerlink m2m technologies reserved rights	
Confidential	Kerlink – 1 rue Jacqueline Auriol – 35235 THORIGNÉ-FOUILLARD	Page 72 / 100
Strict confidential		

Application to Korea (Republic of)

- Upstream channels are in orange (13 channels)
- Downstream channels are in orange (13 channels)
- Unused channels are in yellow
- Channelization is defined by Korean regulation for USN and LPWAN
- Channels must be offset by 100KHz



Figure 34: Channels allocation I in South Korea

Note:

In the above figure:

- Upstream / downstream channels in orange:
 - 13 channels from 920.9 MHz to 923.3 MHz by steps of 200 kHz
 - 125 kHz BW LoRa modulation
 - SF7 to SF12
- Unused channels are in yellow
- Channels are offset by 100KHz compared to other countries due to Korean regulations constraints

Classification	This document is the strict property of Kerlink and shall not be either copied nor sent without express written authorization of Kerlink	
Internal Use	Kerlink m2m technologies reserved rights	
Confidential	Kerlink – 1 rue Jacqueline Auriol – 35235 THORIGNÉ-FOUILLARD	Page 73 / 100
Strict confidential		

2.3.9 Vietnam

The WIFC 923 certification is compliant according to :

- the appendix 3 of the circular 46/2016/TT-BTTTT dedicated to short ranges devices
- QCVN 47:2015/BTTTT
- QCVN 54:2011/BTTTT
- QCVN 96:2015/BTTTT

Type approval certificate No: A0546090718AF04A2. The expiry date is 09/07/2020.

The following label is placed on the outside part of the enclosure:



In Vietnam, the Wirnet™ iFemtoCell 923 can be used with the following limitations:

Item	Specification
Frequency range	918-923MHz
Max ERP	25mW
Max EIRP	16dBm
Max conducted power with 3dBi antenna	13dBm
Duty cycle	1%

The frequency plan and channel allocation is not yet defined in the LoRaWAN specification for Vietnam.

Classification	This document is the strict property of Kerlink and shall not be either copied nor sent without express written authorization of Kerlink	
Internal Use	Kerlink m2m technologies reserved rights	
Confidential	Kerlink – 1 rue Jacqueline Auriol – 35235 THORIGNÉ-FOUILLARD	Page 74 / 100
Strict confidential		

KERLINK recommends the following allocation:

- Upstream channels are in orange (22 channels)
- Downstream channels are in orange (22 channels)
- Unused channels are in yellow

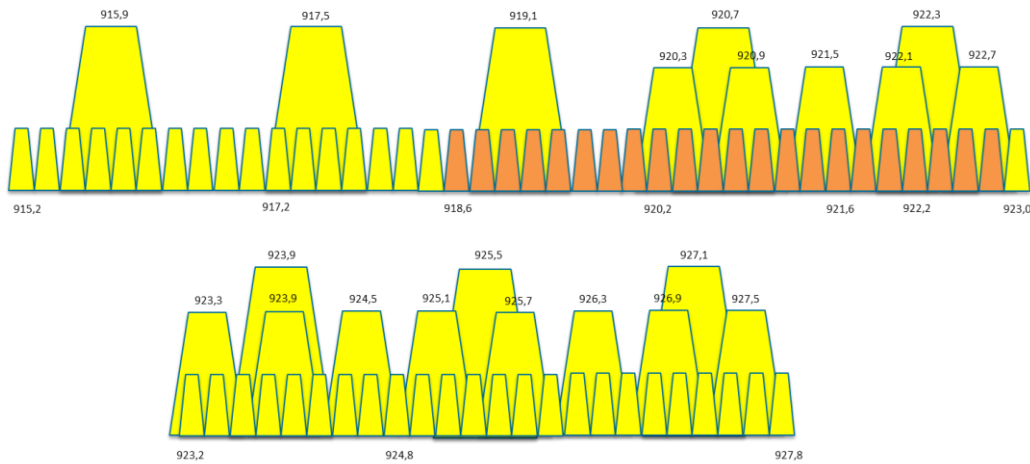

Figure 35: Channels allocation in Vietnam

Note 1:

In the above figure:

- Upstream / downstream channels are in orange:
 - 22 channels from 918.6 MHz to 922.8 MHz by steps of 200 kHz
 - 125 kHz BW LoRa modulation
 - SF7 to SF12
- Unused channels are in yellow

Classification	This document is the strict property of Kerlink and shall not be either copied nor sent without express written authorization of Kerlink	
Internal Use	Kerlink m2m technologies reserved rights	
Confidential	Kerlink – 1 rue Jacqueline Auriol – 35235 THORIGNÉ-FOUILLARD	Page 75 / 100
Strict confidential		

2.3.10 Malaysia

The WIFC 923 a MCMC Type Approval with the identification number : RBDV/32A/0218/S(18-0752). The expiry date is 06/03/2023.

In Malaysia, the WIFC 923 is considered as a Short Range Device (SRD) according to “MCMC MTSFB TC T007: 2014, 1st Rev”.

The WIFC 923 uses the 919-924MHz band with a maximum 500mW EIRP, according to “CLASS ASSIGNMENT NO. 1 OF 2017”.

The following label is placed on the outside part of the enclosure:



In Malaysia, the Wirnet™ iFemtoCell 923 can be used with the following limitations:

Item	Specification
Frequency range	919-923MHz 923-924MHz (1% duty cycle)
Max EIRP	0.5W
Max conducted power with 3dBi antenna	250mW (24dBm)
Channelization	200KHz
Number of channels	19
Channels center frequency	919.2 MHz +n*0.2MHz (0<=n<=18)

The frequency channels arrangement may be compliant to the LoRaWAN specification and the regional parameters (AS 923MHz) as defined in [\[1\]](#) and [\[2\]](#).

KERLINK recommends the following allocation:

Classification	This document is the strict property of Kerlink and shall not be either copied nor sent without express written authorization of Kerlink	
Internal Use	Kerlink m2m technologies reserved rights	
Confidential	Kerlink – 1 rue Jacqueline Auriol – 35235 THORIGNÉ-FOUILLARD	Page 76 / 100
Strict confidential		

- Upstream channels are in orange (23 channels)
- Downstream channels are in orange (23 channels)
- Unused channels are in yellow

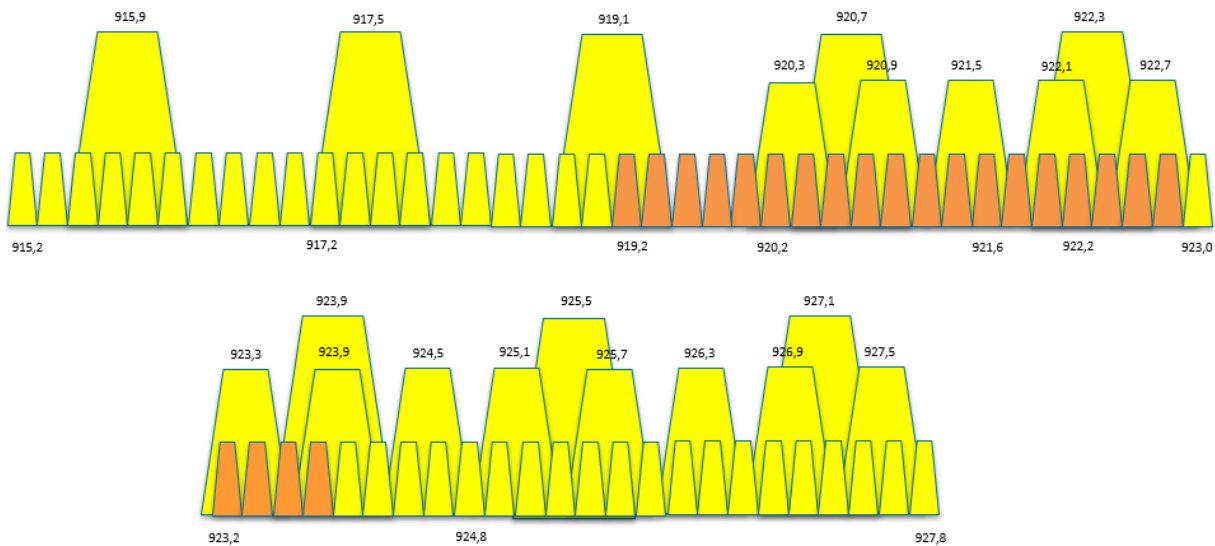

Figure 36: Channels allocation in Malaysia

Note 1:

In the above figure:

- Upstream / downstream channels are in orange:
 - 19 channels from 919.2 MHz to 922.8 MHz by steps of 200 kHz
 - 4 channels from 923.2 MHz to 923.8 MHz by steps of 200 kHz
 - 125 kHz BW LoRa modulation
 - SF7 to SF12
- Unused channels are in yellow

Classification	This document is the strict property of Kerlink and shall not be either copied nor sent without express written authorization of Kerlink	
Internal Use	Kerlink m2m technologies reserved rights	
Confidential	Kerlink – 1 rue Jacqueline Auriol – 35235 THORIGNÉ-FOUILLARD	Page 77 / 100
Strict confidential		

2.3.11 Brazil

In Brazil, the Wirnet™ iFemtoCell 923 is compliant according to:

- Anexo à Resolução nº 680, de 27 de junho de 2017
- Ato nº 14448, Anexo I, de 4 de dezembro de 2017
- Ato nº 950, Anexo I, de 8 de fevereiro de 2018
- Ato nº 952, Anexo I, de 8 de fevereiro de 2018

The Certificate of Conformity (02829-18-11272) is valid until 23/04/2020.

The following label respects the resolution 680:



The following label is placed on the outside part of the enclosure:



In Brazil, the Wirnet™ iFemtoCell 923 can be used with the following limitations:

Item	Specification
Frequency range	915-928MHz
Max EIRP	1W (30dBm)
Max conducted power with 3dBi antenna	27dBm
System type	DSSS / DTS

Be careful:

"Este equipamento não tem direito à proteção contra interferência prejudicial e não pode causar interferência em sistemas devidamente autorizados".

"This equipment has no right to protection against harmful interference and cannot cause interference in duly authorized systems".

The frequency channels arrangement is not defined for Brazil in the LoRaWAN specification and the regional parameters as defined in [1] and [2], but Kerlink recommends following the Australian plan (AU 915-928MHz).

Classification	This document is the strict property of Kerlink and shall not be either copied nor sent without express written authorization of Kerlink	
Internal Use	Kerlink m2m technologies reserved rights	
Confidential	Kerlink – 1 rue Jacqueline Auriol – 35235 THORIGNÉ-FOUILLARD	Page 78 / 100
Strict confidential		

- Upstream channels are in blue (64 + 8 channels)
- Downstream channels are in green (8 channels)
- Unused channels are in yellow

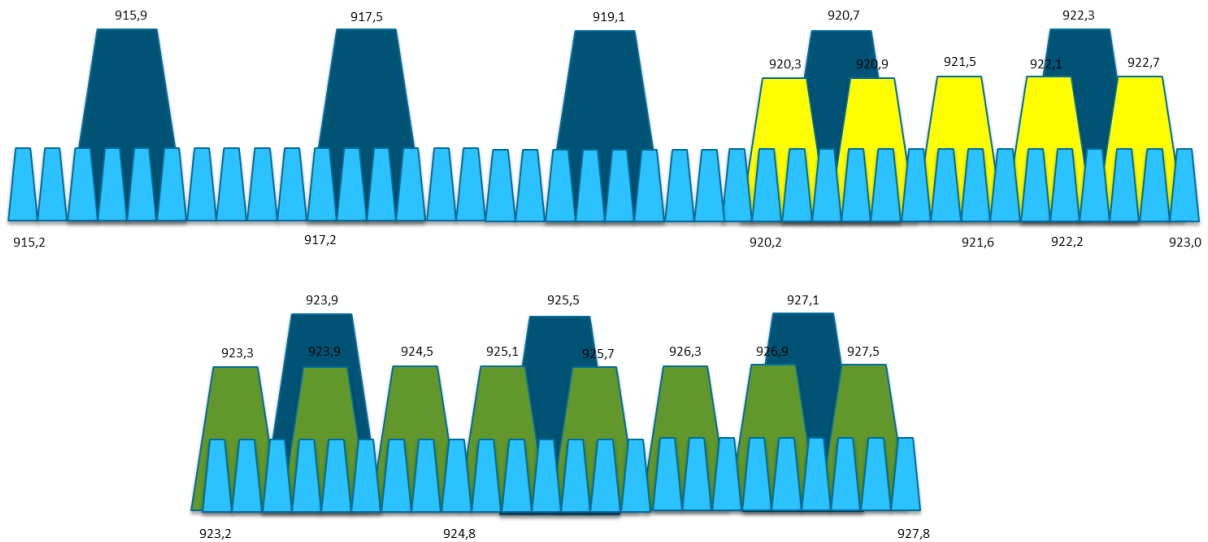

Figure 37: Channels allocation in Brazil

Note 1:

In the above figure:

- Upstream channel are in blue:
 - 64 channels from 915.2 MHz to 927.8 MHz by steps of 200 kHz, 125 kHz BW LoRa modulation, SF7 to SF10
 - 8 channels from 915.9 MHz to 927.1 MHz by steps of 1.6 MHz, with 500 kHz BW LoRa modulation, SF7 to SF12
- Downstream channels are in green:
 - 8 channels from 923.3 MHz to 927.5 MHz by steps of 600 kHz, with 500 kHz BW LoRa modulation, SF7 to SF12
- Unused channels are in yellow

Classification	This document is the strict property of Kerlink and shall not be either copied nor sent without express written authorization of Kerlink	
Internal Use	Kerlink m2m technologies reserved rights	
Confidential	Kerlink – 1 rue Jacqueline Auriol – 35235 THORIGNÉ-FOUILLARD	Page 79 / 100
Strict confidential		

2.3.12 Indonesia

- Wirnet™ iFemtoCell 923 will be ready for SDPPI certification -

The WIFC 923 certification must be completed according to « DECREE OF THE MINISTER OF COMMUNICATION AND INFORMATION TECHNOLOGY OF THE REPUBLIC OF INDONESIA NUMBER 35 YEAR 2015” and “PERSYARATAN TEKNIS ALAT DAN PERANGKAT TELEKOMUNIKASI JARAK DEKAT (SHORT RANGE DEVICE) – 22 November 2012”.

In Indonesia, the Wirnet™ iFemtoCell 923 can be used with the following limitations:

Item	Specification
Frequency range	923-925MHz
Max ERP	500mW (27dBm)
Max EIRP	29dBm
Max conducted power with 3dBi antenna	26dBm
Channelization	200KHz
Number of channels	9
Channels center frequency	923.2 MHz +n*0.2MHz (0<=n<=8)

The frequency channels arrangement must be compliant to the LoRaWAN specification and the regional parameters (AS 923MHz) as defined in [\[1\]](#) and [\[2\]](#).

Classification	This document is the strict property of Kerlink and shall not be either copied nor sent without express written authorization of Kerlink	
Internal Use	Kerlink m2m technologies reserved rights	
Confidential	Kerlink – 1 rue Jacqueline Auriol – 35235 THORIGNÉ-FOUILLARD	Page 80 / 100
Strict confidential		

- Upstream channels are in orange(8 channels)
- Downstream channels are in orange (8 channels)
- Unused channels are in yellow

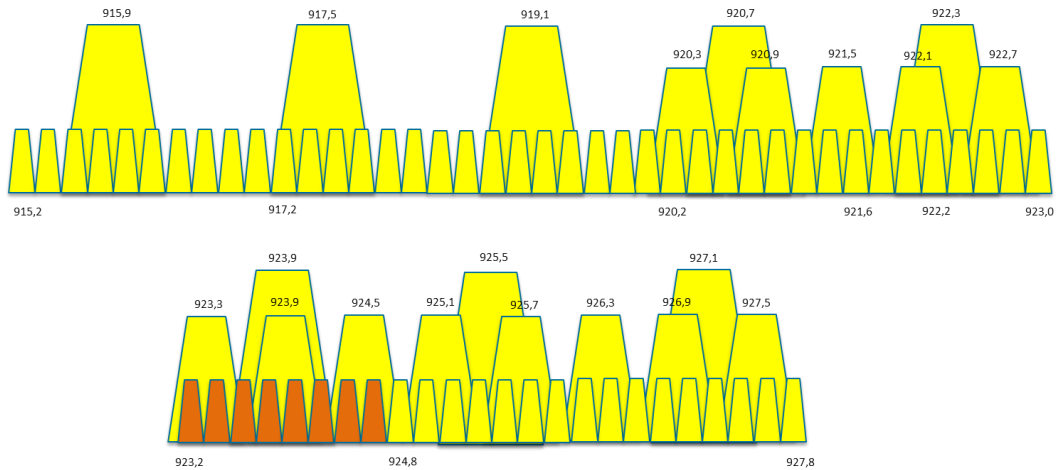

Figure 38: Channels allocation in Indonesia

Note 1:

In the above figure:

- Upstream / downstream channels:
 - 9 channels from 923.2 MHz to 924.8 MHz by steps of 200 kHz
 - 125 kHz BW LoRa modulation
 - SF7 to SF12
- Unused channels are in yellow

Note 2:

Some regulation changes are currently considered in Indonesia for IoT devices. The goal would be an alignment with Malaysian regulation. In this case, the WIFC 923 would be used in the following configuration:

- Frequency range: 919-923 MHz
- Max EIRP: 500 mW
- Upstream / downstream channels:
 - 19 channels from 919.2 MHz to 922.8 MHz by steps of 200 kHz
 - 125 kHz BW LoRa modulation
 - SF7 to SF12

Classification	This document is the strict property of Kerlink and shall not be either copied nor sent without express written authorization of Kerlink	
Internal Use	Kerlink m2m technologies reserved rights	
Confidential	Kerlink – 1 rue Jacqueline Auriol – 35235 THORIGNÉ-FOUILLARD	Page 81 / 100
Strict confidential		

2.3.13 Philippines

The WIFC 923 is compliant to “Memorandum Circular MC 03-08-2013” amending “MC 09-09-2003 for Wireless data Networks and Devices”.

The following label is placed on the outside part of the enclosure:



In Philippines, the Wirnet™ iFemtoCell 923 can be used with the following limitations:

Item	Specification
Frequency range	915-918MHz
Max ERP	250mW
Max conducted power with 3dBi antenna	+23dBm (200mW)
Channelization	200KHz
Number of channels	14
Channels center frequency	915.2 MHz +n*0.2MHz (0<=n<=13)

The frequency plan and channel allocation is not yet defined in the LoRaWAN specification for Philippines.

KERLINK recommends the following allocation:

Classification	This document is the strict property of Kerlink and shall not be either copied nor sent without express written authorization of Kerlink	
Internal Use	Kerlink m2m technologies reserved rights	
Confidential	Kerlink – 1 rue Jacqueline Auriol – 35235 THORIGNÉ-FOUILLARD	Page 82 / 100
Strict confidential		

- Upstream channels are in orange (14 channels)
- Downstream channels are in orange (14 channels)
- Unused channels are in yellow

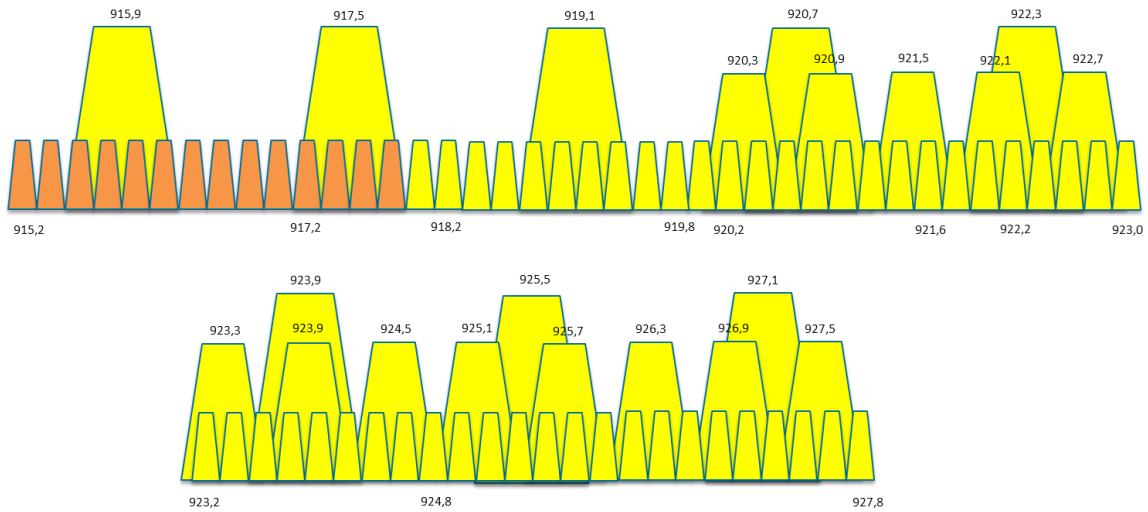

Figure 39: Channels allocation in Philippines

Note 1:

In the above figure:

- Upstream / downstream channels are in orange:
 - 14 channels from 915.2 MHz to 917.8 MHz by steps of 200 kHz
 - 125 kHz BW LoRa modulation
 - SF7 to SF12
- Unused channels are in yellow

Classification	This document is the strict property of Kerlink and shall not be either copied nor sent without express written authorization of Kerlink	
Internal Use	Kerlink m2m technologies reserved rights	
Confidential	Kerlink – 1 rue Jacqueline Auriol – 35235 THORIGNÉ-FOUILLARD	Page 83 / 100
Strict confidential		

3. Installation procedure

This device must be professionally installed.

Changes or modifications not expressly approved by the party responsible for compliance could void the user's authority to operate the equipment.

3.1 Installation topology

3.1.1 Wirnet™ iFemtoCell gateway installation

When a gateway is installed on a site, three configurations are possible regarding WAN technology used:

- Ethernet connection
- Wi-Fi connection
- LTE/HSPA/GPRS connection via USB dongle

The Ethernet connection requires an Ethernet access through a dedicated RJ45 cable.

The Wi-Fi connection requires a Wi-Fi access point.

The LTE/HSPA/GPRS connection requires a USIM subscription and an optional USB dongle. Kerlink recommends using the validated USB dongles (see §5List of the accessories). Alternative dongle may require additional drivers and firmware update to be used.

Obviously, the three configurations may be used in parallel. A typical example is the possibility to insure Ethernet WAN backup by a LTE WAN link.

Classification	This document is the strict property of Kerlink and shall not be either copied nor sent without express written authorization of Kerlink	
Internal Use	Kerlink m2m technologies reserved rights	
Confidential	Kerlink – 1 rue Jacqueline Auriol – 35235 THORIGNÉ-FOUILLARD	Page 84 / 100
Strict confidential		

The three configurations are detailed hereafter:

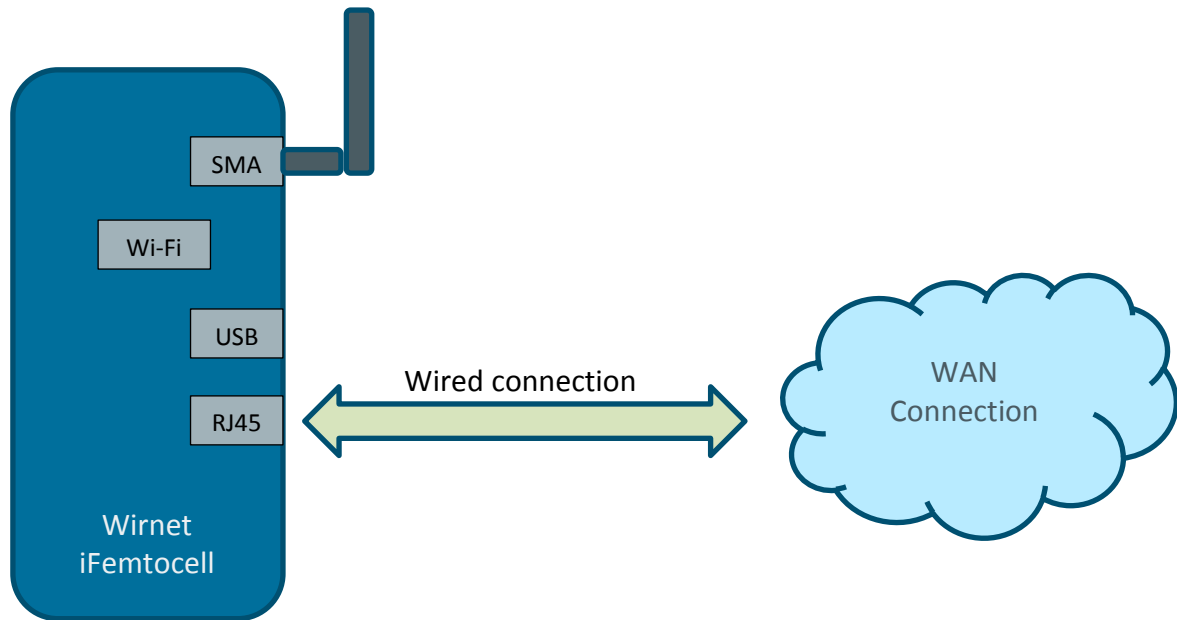

Figure 40: Ethernet WAN connection

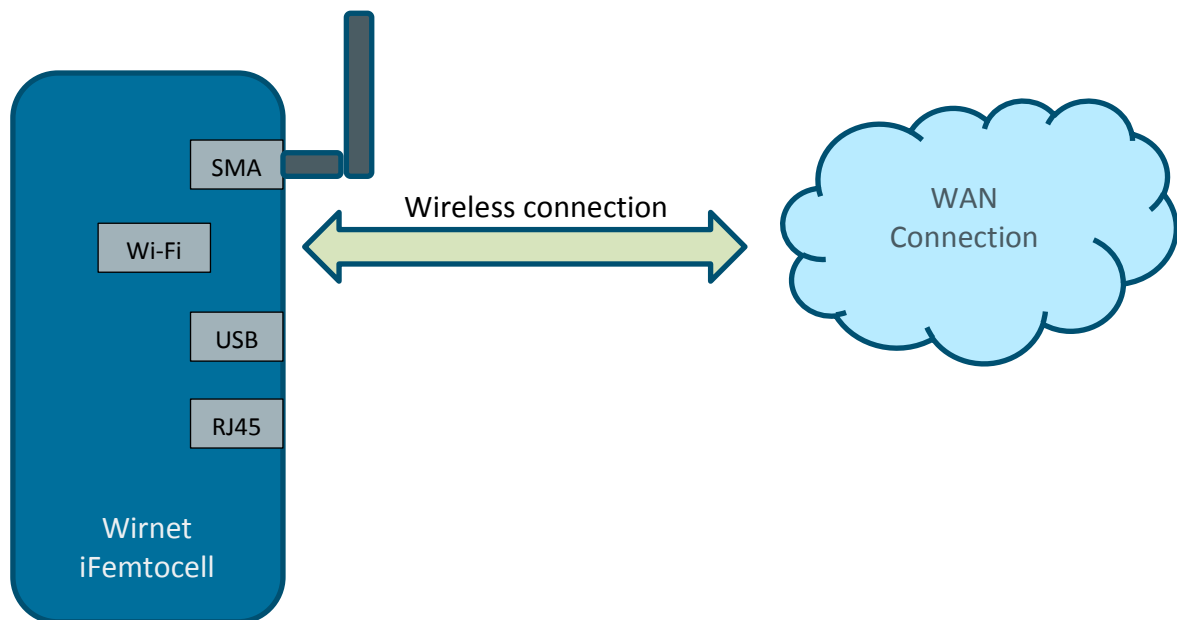

Figure 41: Wi-Fi WAN connection

Classification	This document is the strict property of Kerlink and shall not be either copied nor sent without express written authorization of Kerlink	
Internal Use	Kerlink m2m technologies reserved rights	
Confidential	Kerlink – 1 rue Jacqueline Auriol – 35235 THORIGNÉ-FOUILLARD	Page 85 / 100
Strict confidential		

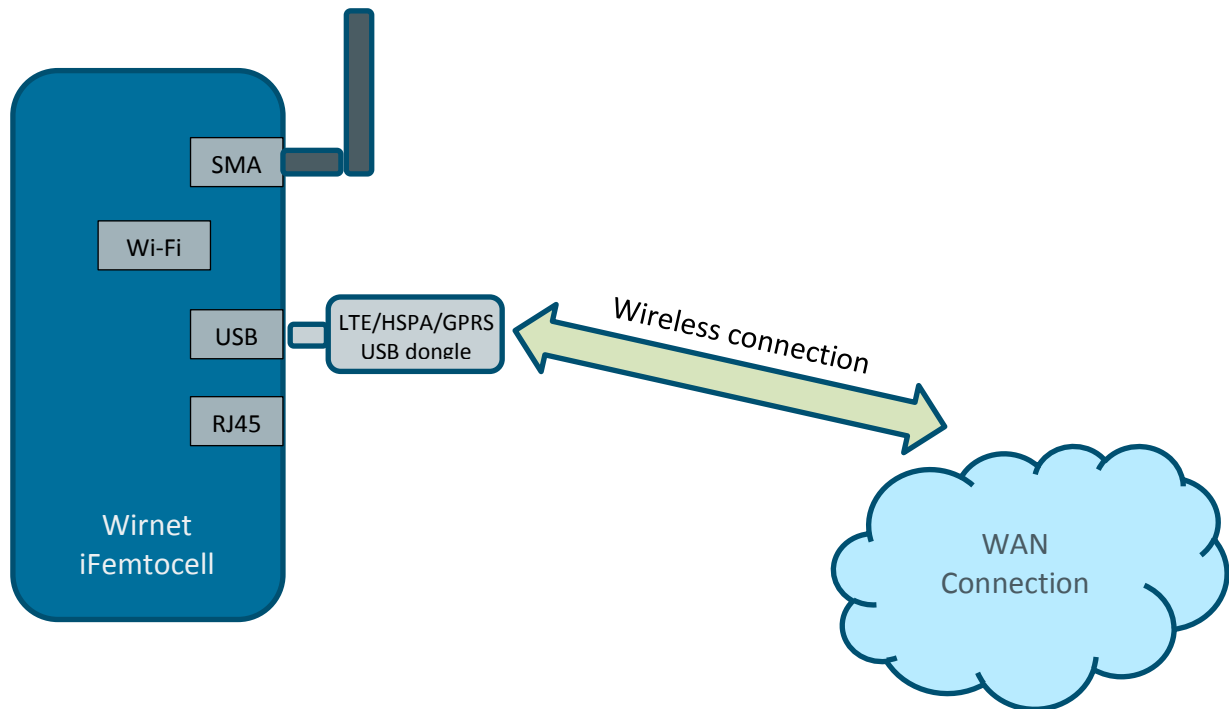

Figure 42: LTE/HSPA/GPRS USB dongle WAN connection

3.2 Mounting of the enclosure

3.2.1 General considerations



The Wirnet™ iFemtoCell enclosure must be mounted on any concrete pedestal, concrete wall or any non-flammable surface (UL94-V0).

It must not be mounted on a flammable surface.

Only two screws are needed.

Detailed information about fixing requirement is available on the corresponding paragraph 1.10.

Classification	This document is the strict property of Kerlink and shall not be either copied nor sent without express written authorization of Kerlink	
Internal Use	Kerlink m2m technologies reserved rights	
Confidential	Kerlink – 1 rue Jacqueline Auriol – 35235 THORIGNÉ-FOUILLARD	Page 86 / 100
Strict confidential		

3.2.2 Distance between LoRa antenna and LTE USB dongle

To avoid or minimize the intermodulation between the LoRa transmitter and the LTE transmitter, a minimum distance is required between the LoRa antenna and the LTE USB dongle. This minimum distance is also recommended to avoid mutual desensitization of the receivers.

To optimize the colocation between the internal LTE USB dongle and the external LoRa antenna, a distance of 1m is required between both radiated parts.

Therefore, when possible, Kerlink strongly recommends dissociating the LTE USB dongle away from the enclosure and the LoRa antenna by using a 1 meter extension cable.

3.3 Setting connections

Before setting all connections, ensure that the power supply is not connected to the mains supply.

The following pictures details all the Wirnet™ iFemtoCell required connections, including power supply cable, Ethernet cable, USB mass-storage key and LoRa antenna connections:



Figure 43: Connections

Classification	This document is the strict property of Kerlink and shall not be either copied nor sent without express written authorization of Kerlink	
Internal Use	Kerlink m2m technologies reserved rights	
Confidential	Kerlink – 1 rue Jacqueline Auriol – 35235 THORIGNÉ-FOUILLARD	Page 87 / 100
Strict confidential		

The Wirnet™ iFemtoCell gateway is provided with:

- Power supply detailed in §1.3
- LoRa antenna detailed in §1.5

The recommended Ethernet cable is detailed in §1.12.1.

Note 1: The Ethernet cable is not provided with the Wirnet™ iFemtoCell.

Note 2: The maximum Ethernet cable length is 100m.

The power supply detailed in §1.3 is provided with E/F type cable (Europe) or B type cable (USA).

Insert the plugs to the mains receptacle of the electrical installation.

The power supply for the Wirnet™ iFemtoCell 923 is provided with 6 different plugs, take the right plug according to the country.

Note: The E/F type or B type plugs must be inserted into the mains receptacle only once all other connections are settled and USIM card inserted (see §3.4).

3.4 Commissioning

3.4.1 USIM card

The LTE/HSPA/GPRS connection requires a USIM subscription and an optional USB dongle. Kerlink recommends using the validated USB dongles (see §5List of the accessories). Alternative dongle may require additional drivers and firmware update to be used.

The USIM card is mandatory to establish the LTE/3G/GPRS communications.

KERLINK recommends the usage of a M2M UICC compliant with 3GPP TS 102.671. It offers then a better temperature operating range, improved data retention and increased number of UPDATE commands.

Before inserting the USIM card, pay attention that the Wirnet™ iFemtoCell is unpowered by checking that all LEDs are OFF.

Then, insert a USIM card in the USB WAN dongle.

In case of replacement of the USIM card, the power supply must be firstly switched off by disconnecting the power supply. Wait and check the LEDs are switched off before extracting the USIM card.

Classification	This document is the strict property of Kerlink and shall not be either copied nor sent without express written authorization of Kerlink	
Internal Use	Kerlink m2m technologies reserved rights	
Confidential	Kerlink – 1 rue Jacqueline Auriol – 35235 THORIGNÉ-FOUILLARD	Page 88 / 100
Strict confidential		

After inserting the new USIM card as described above, the Wirnet™ iFemtoCell can be re-powered on again.

In case of change of mobile operator, APN and login/password must be updated. This can be done through USB update.

For more details, contact KERLINK.

3.4.2 Power ON

Once the RF antenna, the Ethernet cable and the power supply jack connector are connected and the USIM card is inserted, the Wirnet™ iFemtoCell can be powered ON.

To POWER ON the Wirnet™ iFemtoCell, connect the power supply onto the 230VAC mains supply.

3.4.3 Functional check

To ensure the Wirnet™ iFemtoCell is started up, check the behavior of the LED indicators:



Figure 44: Functional check with LEDs

Classification	This document is the strict property of Kerlink and shall not be either copied nor sent without express written authorization of Kerlink	
Internal Use	Kerlink m2m technologies reserved rights	
Confidential	Kerlink – 1 rue Jacqueline Auriol – 35235 THORIGNÉ-FOUILLARD	Page 89 / 100
Strict confidential		

Item	Specification
LED 1: Power	Red blinking during the kernel boot Green blinking during system boot Green when boot is finished
LED 2: Backhaul	Red during boot Red if PacketForwarder is disconnected Green blinking during PacketForwarder connection Green fix if PacketForwarder is connected
LED 3: LoRa traffic	Red during boot PacketForwarder management Rx: green blinking Tx: red blinking

Then, to check and analyze the status of the Wirnet™ iFemtoCell, a standard laptop can be connected to the RJ45 connector or a Wi-Fi connection may be done.

3.4.4 First connection

When a gateway is installed, the first connection must be done by two different ways:

- Ethernet connection
- Wi-Fi connection

3.4.4.1 Ethernet connection

Plug the Wirnet™ iFemtoCell to the WAN access point with an Ethernet cable.

The connection will be established automatically.

3.4.4.2 Wi-Fi connection

If you have a WPS-compatible (Wi-Fi Protected Setup) Wi-Fi Access Point, press the WPS button on the Wirnet™ iFemtoCell (§1.8 Push buttons), and then press the WPS button on the Wi-Fi Access Point of the installation.

The connection will be established automatically.

Alternatively, if you do not have a WPS-compatible Wi-Fi Access Point, you can connect directly to the Wirnet™ iFemtoCell through Wi-Fi. Please consult the Kerlink Wiki or contact KERLINK for more information.

Classification	This document is the strict property of Kerlink and shall not be either copied nor sent without express written authorization of Kerlink	
Internal Use	Kerlink m2m technologies reserved rights	
Confidential	Kerlink – 1 rue Jacqueline Auriol – 35235 THORIGNÉ-FOUILLARD	Page 90 / 100
Strict confidential		

3.4.5 Configuration

Once the connection is established, the Wirnet™ iFemtoCell can be graphically configured through a web interface. To access it, you must have a computer connected either to the same Ethernet or Wi-Fi network, or directly through the Wirnet™ iFemtoCell Wi-Fi. Please consult Kerlink Wiki or contact Kerlink for more information and to get the credentials. You will be greeted with the following screen:



Figure 45: Web interface login screen

The maintenance Web interface is described in chapter 4.2.3.

For information the host name of the Wirnet™ iFemtoCell is “klk-wifc-xxxxxx” where xxxxxx is the end of the board ID. This information is present on the sticker placed on the rear side of the product. In this example, xxxxxx is 030178.

Classification	This document is the strict property of Kerlink and shall not be either copied nor sent without express written authorization of Kerlink	
Internal Use	Kerlink m2m technologies reserved rights	
Confidential	Kerlink – 1 rue Jacqueline Auriol – 35235 THORIGNÉ-FOUILLARD	Page 91 / 100
Strict confidential		



Figure 46: Board ID

Classification	This document is the strict property of Kerlink and shall not be either copied nor sent without express written authorization of Kerlink	
Internal Use	Kerlink m2m technologies reserved rights	
Confidential	Kerlink – 1 rue Jacqueline Auriol – 35235 THORIGNÉ-FOUILLARD	Page 92 / 100
Strict confidential		

4. Maintenance of the Wirnet™ iFemtoCell

4.1 Simple checks

4.1.1 Wirnet™ iFemtoCell enclosure

Check the robustness of the installation:

- Screwing of the Wirnet™ iFemtoCell in case of wall mounting

Check connections:

- Tightening of the antenna (SMA connector)
- Position/good connection of the power supply jack connector
- Position/good connection of the RJ45 Ethernet connector
- RJ45 cable is not deteriorated
- LoRa antenna is not deteriorated

4.1.2 User interface

Check the LED indicators on the top of the enclosure:



Figure 47: Maintenance check with LEDs

Classification	This document is the strict property of Kerlink and shall not be either copied nor sent without express written authorization of Kerlink	
Internal Use	Kerlink m2m technologies reserved rights	
Confidential	Kerlink – 1 rue Jacqueline Auriol – 35235 THORIGNÉ-FOUILLARD	Page 93 / 100
Strict confidential		

Item	Specification
LED 1: Power	Red blinking during the kernel boot Green blinking during system boot Green when boot is finished
LED 2: Backhaul	Red during boot Red if PacketForwarder is disconnected Green blinking during PacketForwarder connection Green fix if PacketForwarder is connected
LED 3: LoRa traffic	Red during boot PacketForwarder management Rx: green blinking Tx: red blinking

4.2 Interfaces for debug or maintenance purposes

4.2.1 USB interface / Firmware upgrade

Firmware upgrade can be performed with a USB key via the USB type A connector. The connector is located on the left side of the enclosure as described below:



Figure 48: USB dongle on the Wirnet™ iFemtoCell

Classification	This document is the strict property of Kerlink and shall not be either copied nor sent without express written authorization of Kerlink	
Internal Use	Kerlink m2m technologies reserved rights	
Confidential	Kerlink – 1 rue Jacqueline Auriol – 35235 THORIGNÉ-FOUILLARD	Page 94 / 100
Strict confidential		

4.2.1.1 Overview

- 1) Prepare a USB disk with following files:
 - *usb.autorun*: Auto executable script
 - *usbkey.txt*: USB password file
 - *keros_x.y.z.ipk*: the update package
- 2) Plug the USB disk on the Wirnet™ iFemtoCell product
- 3) Wait until green LED 1 stop blinking
- 4) Unplug USB disk
- 5) Wait for CPU reboot (Green LED 1)
- 6) Verify the new version inside the file */tmp/sys_startup_status.json*, firmware version of product is contained in the field "cpu"."sw_version"

4.2.1.2 Specific Files

The 2 specific files for USB update are *usb.autorun* and *usbkey.txt*:

- *usbkey.txt* is a security file. It includes the "usbuser" password on the UC board. The password of usbuser is, by default "USBklkPassword" ("*<serialNo>_usbkey*" for firmwares versions < 1.5.0).
- *usb.autorun* is a script automatically executed by the board if the *usbkey.txt* file includes a correct password.

Visit Wirnet™ iFemtoCell Wiki for additional information:

<http://www.wikikerlink.fr/wirnet-ifemtocell/>

Classification	This document is the strict property of Kerlink and shall not be either copied nor sent without express written authorization of Kerlink	
Internal Use	Kerlink m2m technologies reserved rights	
Confidential	Kerlink – 1 rue Jacqueline Auriol – 35235 THORIGNÉ-FOUILLARD	Page 95 / 100
Strict confidential		

4.2.2 Push buttons

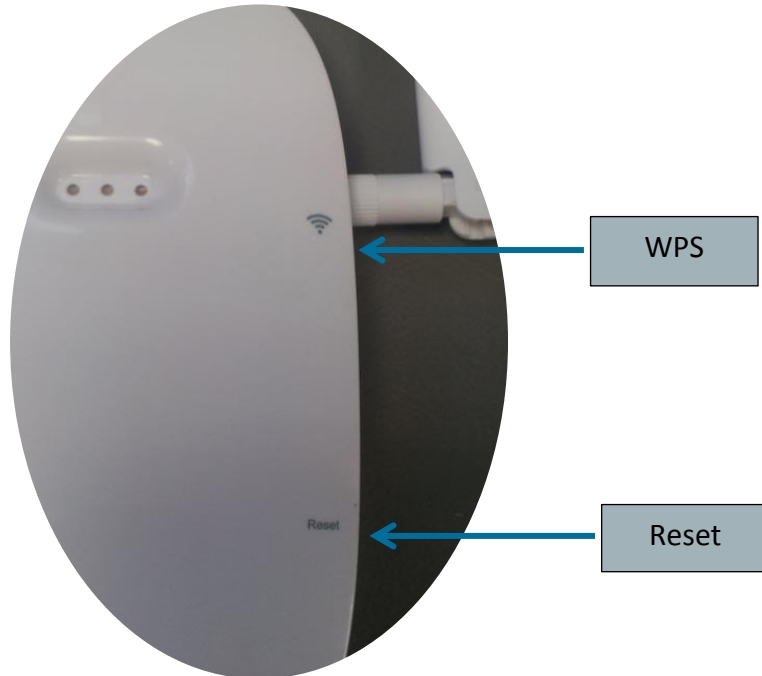

Figure 49: Push buttons

To press the buttons, a tool with a 1mm diameter must be used:



Figure 50: Push button tool

Classification	This document is the strict property of Kerlink and shall not be either copied nor sent without express written authorization of Kerlink	
Internal Use	Kerlink m2m technologies reserved rights	
Confidential	Kerlink – 1 rue Jacqueline Auriol – 35235 THORIGNÉ-FOUILLARD	Page 96 / 100
Strict confidential		

4.2.2.1 Reset push button

The reset push button must be pressed during 1s to generate a hard reset of the product.

4.2.2.2 WPS

Wi-Fi Protected Setup (WPS) is a standard used to establish a secure connection between equipment and a Wi-Fi access point.

The principle is to press the WPS button on the Wirnet™ iFemtoCell and on the Wi-Fi access point to get the connection.

4.2.3 Local Web maintenance interface

Once the connection is established (Ethernet or Wi-Fi), a configuration Web page is accessible from the product.

The following list gives a brief sum up of the configuration possibilities:

- Ethernet configuration
 - IPv4 mode: Automatic (DHCP) or Manual (static) or Off (disabled)
 - IPv4 address (if static mode)
 - IPv4 Gateway address & network mask
 - IPv4 DNS resolver
- Wi-Fi configuration
 - SSID
 - Password
 - Scanning (SSID, RSSI)
- GSM / HSPA / LTE:
 - USIM pincode
 - APN
 - Login
 - Password
- Security credentials:
 - Change of admin user password

Consult the Kerlink Wiki or contact KERLINK for more information.

5. List of the accessories

Basic configuration 868:

KERLINK Reference	Designation
PDTIOT-IFE00	Wirnet™ iFemtocell 868, including: <ul style="list-style-type: none"> - 1 X Enclosure with a CPU board - 1 X Power supply

Classification	This document is the strict property of Kerlink and shall not be either copied nor sent without express written authorization of Kerlink		
Internal Use	Kerlink m2m technologies reserved rights		
Confidential	Kerlink – 1 rue Jacqueline Auriol – 35235 THORIGNÉ-FOUILLARD		Page 97 / 100
Strict confidential			

- 1 X LoRa antenna

Basic configuration 915:

KERLINK Reference	Designation
PDTIOT-IFE01	Wirnet™ iFemtocell 915, including: <ul style="list-style-type: none"> - 1 X Enclosure with a CPU board - 1 X Power supply - 1 X LoRa antenna

Basic configuration 923:

KERLINK Reference	Designation
PDTIOT-IFE02	Wirnet™ iFemtocell 923, including: <ul style="list-style-type: none"> - 1 X Enclosure with a CPU board - 1 X Power supply - 1 X LoRa antenna

LTE/HSPA/GPRS USB Dongle:

Designation
- Huawei E3372h-153 non-HiLink (PPP & NDIS) -> 4G/ EMEA
- Huawei E3372h-510 non-HiLink (PPP & NDIS) -> 4G/ North America
- Huawei 3372h-607 non-HiLink (PPP & NDIS) -> 4G/ APAC
- Huawei MS2131-> 3G/ Worldwide

6. KERLINK support

The Wirnet™ iFemtoCell gateway must be installed and maintained by authorized and qualified personnel only.

In case of defect or breakdown, make sure the above recommendations detailed in this document are met.

If an issue is not addressed in this document, contact KERLINK at support@kerlink.fr.

Classification	This document is the strict property of Kerlink and shall not be either copied nor sent without express written authorization of Kerlink	
Internal Use	Kerlink m2m technologies reserved rights	
Confidential	Kerlink – 1 rue Jacqueline Auriol – 35235 THORIGNÉ-FOUILLARD	Page 99 / 100
Strict confidential		

END OF DOCUMENT

Classification	This document is the strict property of Kerlink and shall not be either copied nor sent without express written authorization of Kerlink	
Internal Use	Kerlink m2m technologies reserved rights	
Confidential	Kerlink – 1 rue Jacqueline Auriol – 35235 THORIGNÉ-FOUILLARD	Page 100 / 100
Strict confidential		