



Smart Scene Panel

Featuring LoRaWAN[®]

WS136 & WS156

User Guide



Safety Precautions

Milesight will not shoulder responsibility for any loss or damage resulting from not following the instructions of this operating guide.

- ❖ The device must not be modified in any way.
- ❖ In order to protect the security of the device, please change device the password when first configuration. The default password is 123456.
- ❖ Do not place the device close to objects with naked flames.
- ❖ Do not place the device where the temperature is below/above the operating range.
- ❖ When installing the battery, please install it accurately, and do not install the reverse or wrong model.
- ❖ Remove the battery if the device will not be used for a while. Otherwise, the battery will leak and damage the device.
- ❖ Make sure both batteries are newest when install, or battery life will be reduced.
- ❖ The device must never be subjected to shocks or impacts.

Declaration of Conformity

WS136 & WS156 is in conformity with the essential requirements and other relevant provisions of the CE, FCC, and RoHS.

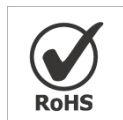

Copyright © 2011-2022 Milesight. All rights reserved.

All information in this guide is protected by copyright law. Whereby, no organization or individual shall copy or reproduce the whole or part of this user guide by any means without written authorization from Xiamen Milesight IoT Co., Ltd.

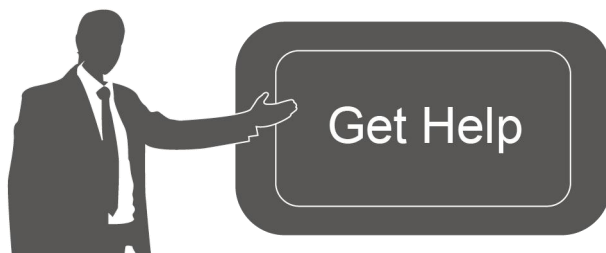

For assistance, please contact

Milesight technical support:

Email: iot.support@milesight.com

Tel: 86-592-5085280

Fax: 86-592-5023065

Address: Building C09, Software Park III,
Xiamen 361024, China

Revision History

Date	Doc Version	Description
Oct. 19, 2021	V 1.0	Initial version

Contents

1. Product Introduction.....	4
1.1 Overview.....	4
1.2 Features.....	4
2. Hardware Introduction.....	4
2.1 Packing List.....	4
2.2 Hardware Overview.....	5
2.3 Dimensions.....	5
2.4 LED Patterns.....	5
3. Operation Guide.....	5
3.1 NFC Configuration.....	5
3.2 LoRaWAN Settings.....	6
3.3 General Settings.....	9
3.4 LoRa D2D Settings.....	9
3.5 E-ink Screen Display Settings.....	10
3.6 Maintenance.....	11
3.6.1 Upgrade.....	11
3.6.2 Backup.....	12
3.6.3 Reboot and Reset.....	13
4. Installation.....	14
5. Device Payload.....	14
5.1 Basic Information.....	14
5.2 Button Message.....	15
5.3 Downlink Commands.....	16

1. Product Introduction

1.1 Overview





WS136 & WS156 is a LoRaWAN® based smart panel for wireless controls, triggers and alarms. Without any additional cable, WS136 & WS156 can be easily installed anywhere and control devices via LoRaWAN or Milesight LoRa D2D communication protocol. Besides, it's equipped a user-definable E-ink screen to suit different scenes. WS136 & WS156 can be widely used in smart home, smart office, hotel, school, etc.

1.2 Features

- Equipped with a programmable E-ink screen for flexible display
- Up to 6 scenes settable, each scene can consist of multiple devices
- Easy configuration via NFC
- Standard LoRaWAN® support
- Milesight IoT Cloud compliant
- LoRa D2D control without gateway
- Compact design, easy to install

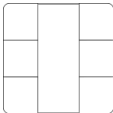
2. Hardware Introduction

2.1 Packing List

			
1 ×	1 ×	1 ×	1 ×
WS136 or WS156 Device	3M Tape	Warranty Card	Quick Guide



If any of the above items is missing or damaged, please contact your sales representative.

2.2 Hardware Overview

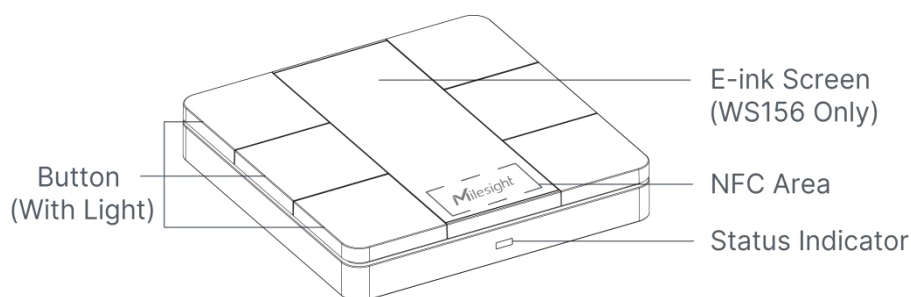

2.3 Dimensions (mm)

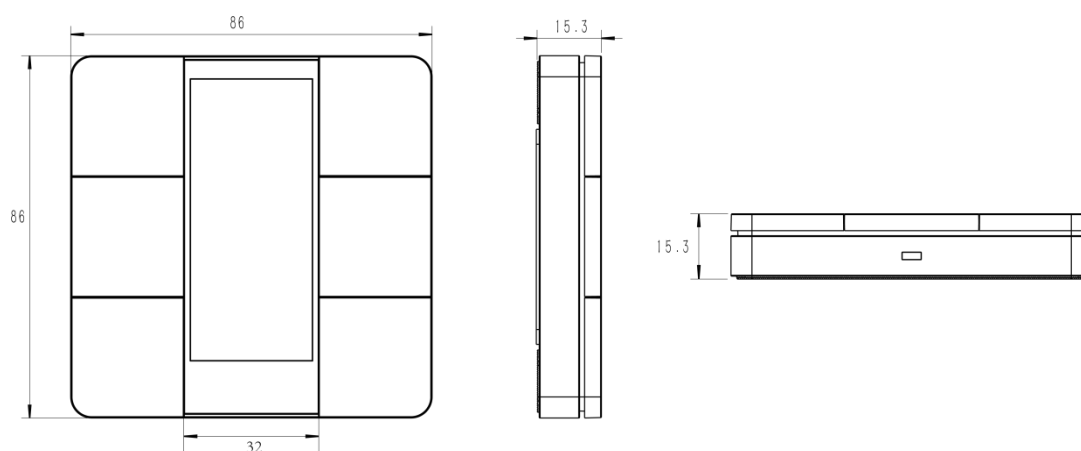

2.4 LED Patterns

Indicator	Action	Indication
Button Light	Press the button	Always on until the button is being released
Status Indicator	Send join network requests	Blinks as requests
	Joined the network successfully	Blinks twice
	Receive ACK packages from NS	Blinks once

3. Operation Guide

3.1 NFC Configuration

WS136 & WS156 can be configured via NFC-enabled smartphone.

1. Open the enclosure of the device, pull out the inside battery insulating sheets to power on the device.

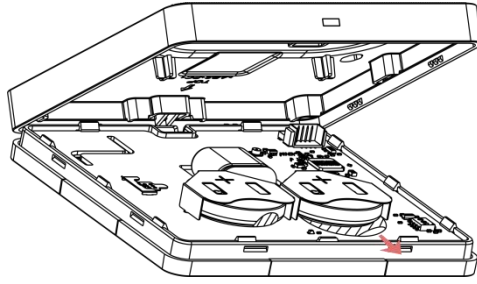

2. Download and install “Milesight ToolBox” App from Google Play or App Store.
3. Enable NFC on the smartphone and open Milesight ToolBox.
4. Attach the smartphone with NFC area to the device to read device information.

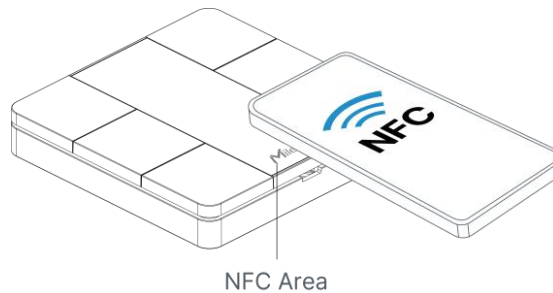

5. Basic information and settings of the device will be shown on ToolBox if it's recognized successfully. You can read and configure the device by tapping the Read/Write button on the App. In order to protect the security of devices, password validation is required when first configuration. The default password is **123456**.

Note:

- 1) Ensure the position of smartphone NFC area and it's recommended to take off phone case.
- 2) If the smartphone fails to read/write configurations via NFC, move the phone away and back to try again.
- 3) WS136 & WS156 can also be configured by ToolBox software via dedicated NFC reader provided by Milesight IoT.

3.2 LoRaWAN Settings

LoRaWAN settings are used for configuring the transmission parameters in LoRaWAN® network.

Basic LoRaWAN Settings:

Go to **Device -> Setting -> LoRaWAN Settings** of ToolBox App to configure join type, App EUI, App Key and other information. You can also keep all settings by default.

Device EUI	<input type="text" value="24E124127A270222"/>
App EUI	<input type="text" value="24E124C0002A0001"/>
Application Port	<input type="text" value="85"/>
Join Type	<input type="text" value="OTAA"/>
Application Key	<input type="text" value="*****"/>
Spread Factor	<input type="text" value="SF10-DR2"/>
Confirmed Mode	<input type="checkbox"/>
Rejoin Mode	<input checked="" type="checkbox"/>
Set the number of packets sent	<input type="text" value="32"/> packets
ADR Mode	<input checked="" type="checkbox"/>

Parameters	Description
Device EUI	Unique ID of the device which can also be found on the label.
App EUI	Default App EUI is 24E124C0002A0001.
Application Port	The port is used for sending and receiving data, the default port is 85.
Join Type	OTAA and ABP modes are available.
Application Key	Appkey for OTAA mode, default is 5572404C696E6B4C6F52613230313823.
Device Address	DevAddr for ABP mode, default is the 5 th to 12 th digits of SN.
Network Session Key	Nwkskey for ABP mode, default is 5572404C696E6B4C6F52613230313823.
Application Session Key	Appskey for ABP mode, default is 5572404C696E6B4C6F52613230313823.
Spread Factor	If ADR is disabled, the device will send data via this spread factor.
Confirmed Mode	If the device does not receive ACK packet from network server, it will resend data 3 times at most.
Rejoin Mode	Reporting interval \leq 30 mins: the device will send specific mounts of LoRaMAC packets to check connection status every 30 mins; If no reply after specific packets are being sent, the device will re-join. Reporting interval $>$ 30 mins: the device will send specific mounts of LoRaMAC packets to check connection status at every reporting interval; If no reply after specific packets are being sent, the device will re-join.
ADR Mode	Allow network server to adjust datarate of the device.
Tx Power	Transmit power of the device.

Note:

- 1) Please contact sales representative for device EUI list if there are many units.
- 2) Please contact sales representative if you need random App keys before purchase.
- 3) Select OTAA mode if you use Milesight IoT Cloud to manage devices.
- 4) Only OTAA mode supports rejoin mode.

LoRaWAN Frequency Settings:

Go to “**Setting->LoRaWAN Settings**” of ToolBox App to select supported frequency and select channels to send uplinks. Make sure the channels match the LoRaWAN® gateway.

* Support Frequency

AS923

<input checked="" type="checkbox"/>	-	923.2	+
<input checked="" type="checkbox"/>	-	923.4	+
<input type="checkbox"/>	-	922.2	+
<input type="checkbox"/>	-	922.4	+
<input type="checkbox"/>	-	922.6	+

If device frequency is one of CN470/AU915/US915, you can enter the index of the channel that you want to enable in the input box, making them separated by commas.

Examples:

1, 40: Enabling Channel 1 and Channel 40

1-40: Enabling Channel 1 to Channel 40

1-40, 60: Enabling Channel 1 to Channel 40 and Channel 60

All: Enabling all channels

Null: Indicates that all channels are disabled

* Support Frequency

AU915

Enable Channel Index ⓘ

0-71

Index	Frequency/MHz ⓘ
0 - 15	915.2 - 918.2
16 - 31	918.4 - 921.4
32 - 47	921.6 - 924.6
48 - 63	924.8 - 927.8

Note:

For -868M model, default frequency is EU868;

For -915M model, default frequency is AU915.

3.3 General Settings

Go to "Device->Setting->General Settings" of ToolBox App to change the reporting interval, etc.

Reporting Interval 1 min

Change Password

Parameters	Description
Reporting Interval	Reporting interval of battery level to network server. Default: 1080 min
Change Password	Change the password for ToolBox App to write this device.

3.4 LoRa D2D Settings

LoRa D2D protocol is developed by Milesight and used for setting up transmission among Milesight LoRaWAN® devices without gateway. When the LoRa D2D setting is enabled, WS136 & WS156 can work as a LoRa D2D controller for sending control commands to trigger LoRa D2D agent devices.

1. Enable LoRa D2D feature.
2. Define a unique LoRa D2D key that is the same as LoRa D2D agent devices, then

select the frequency and spreading factor. (Default LoRa D2D Key: 5572404C696E6B4C6F52613230313823)

LoRa D2D Settings ^

Enable

LoRa D2D Key

Spread Factor

SF12-DR0
▼

Frequency/MHz - 9.525 +

3. Enable one of WS136 & WS156 button mode and configure a 2-byte hexadecimal command (This command is pre-defined in LoRa D2D agent device). When you press this button, WS136 & WS156 will send the control command to corresponding LoRa D2D agent devices.

Note: When this feature is enabled, the control command from this button will not send to LoRaWAN® gateway.

Scenario Button 1

Control command

0001

Scenario Button 2

Scenario Button 3

3.5 E-ink Screen Display Settings

- WS156 supports e-ink screen display content programming according to user requirements.
1. Every button shows 1 to 6 numbers by default. Users can modify these numbers to any characters or click "Custom" to import pictures.
 2. After modifying or importing, click "Preview" to check the display result on the upper picture.
 3. Click "Write", then attach the smartphone with NFC area to the device to complete the screen programming.
 4. Click "Save" to save the current display as a template in Toolbox App. You can import this template to another device by clicking "Import Template".

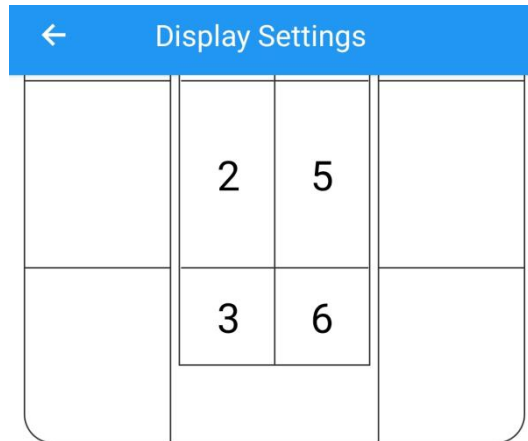

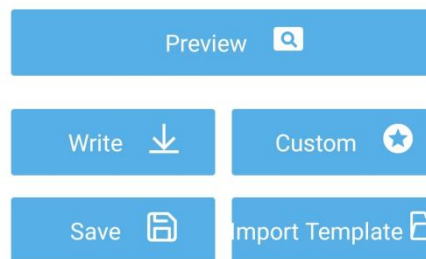

Enter a name for each key

Button 1: Button 4:
 Button 2: Button 5:
 Button 3: Button 6:



Note:

1) WS156 e-ink screen will show below fixed icons:

Icon	Description
	Battery level
	The device joins the network.
	The device fails to join the network.

2) WS156 do a full-screen refresh once a week in order to remove ghosting.

3.6 Maintenance

3.6.1 Upgrade

1. Download firmware from Milesight website to your smartphone.
2. Open ToolBox App and click "Browse" to import firmware and upgrade the device.

Note:

- 1) Operation on ToolBox is not supported during the upgrade.
- 2) Only Android version ToolBox supports the upgrade feature.

Status	Setting	Maintenance
SN		6592B3252938
Model		WS156-470M
Firmware Version		V1.2-a2
Hardware Version		V1.0
Manual Upgrade		
<input type="button" value="Browse"/>		

3.6.2 Backup

WS136 & WS156 supports configuration backup for easy and quick device configuration in bulk.

Backup is allowed only for devices with the same model and LoRa frequency band.

1. Go to "Template" page on the App and save current settings as a template. You can also edit the template file.
2. Select one template file that saved in the smartphone and click "Write", then attach it to another device to write configuration.

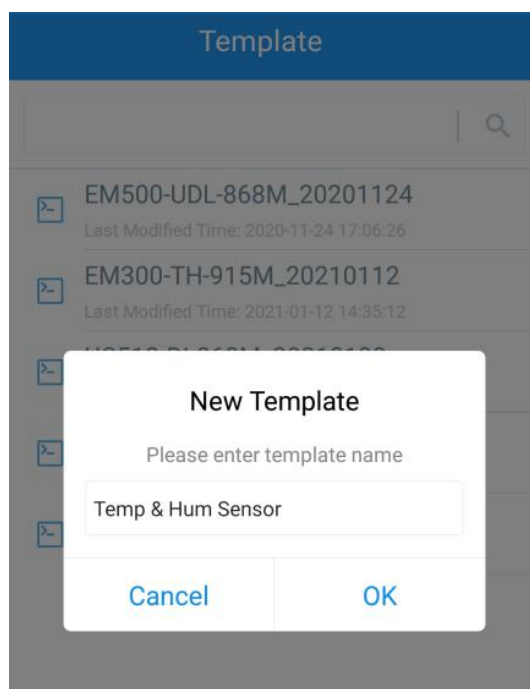

Note: Slide the template item to the left to edit or delete the template. Click the template to edit the configurations.

Template

Q

> EM500-UDL-868M_20201124
Last Modified Time: 2020-11-24 17:06:26

> EM300-TH-915M_20210112
Last Modified Time: 2021-01-12 14:35:12

> UC512-DI-868M_20210128
Last Modified Time: 2021-01-28 16:57:20

> UC501-470M_20210201
Last Modified Time: 2021-02-01 11:29:43

> M_20210208
Last Modified Time: 2021-02-08 16:44:37

Edit
Delete

3.6.3 Reboot and Reset

Via Hardware: Hold on the button inside the device for 3s to reboot, 10s to reset.

Via ToolBox App: Go to "Device -> Maintenance" to tap "Restart" or "Reset", then attach smartphone with NFC area to the device to complete reboot or reset.

Status	Setting	Maintenance
SN		6592B3252938
Model		WS156-470M
Firmware Version		V1.2-a2
Hardware Version		V1.0
Manual Upgrade		
<div style="background-color: #007bff; color: white; text-align: center; padding: 5px 20px; border-radius: 5px;">Browse</div>		
Restore Factory Default		
<div style="background-color: #007bff; color: white; text-align: center; padding: 5px 20px; border-radius: 5px;">Reset</div>		
<div style="background-color: #007bff; color: white; text-align: center; padding: 5px 20px; border-radius: 5px;">Restart</div>		

4. Installation

WS136 & WS156 can be placed on the desktop directly. If it needs to be fixed, please try below installation methods.

Fixed by 3M Tapes:

Paste 3M tape to the back of the panel, then tear the other side and place it on a flat surface. Please note the screen direction when installing.

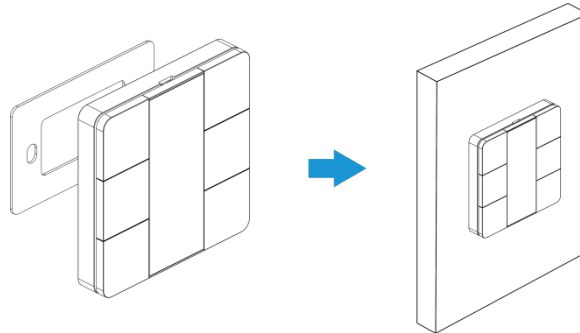

Fixed by 86 Box:

Remove the back cover of the panel, screw the back cover to the 86 box with screws, then install back the panel. Please note the screen direction when installing.

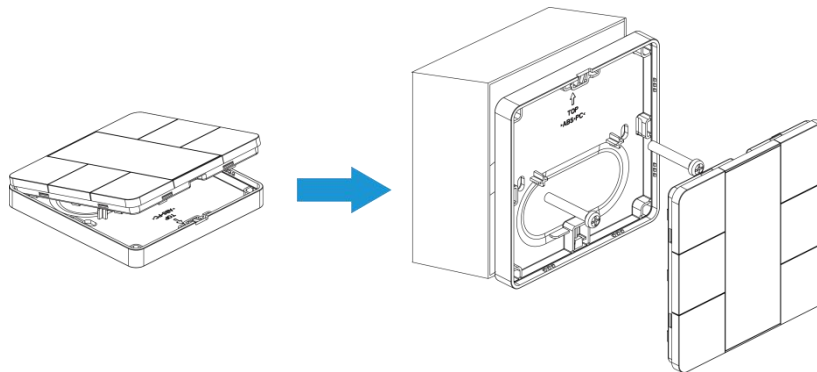

5. Device Payload

All data are based on the following format(HEX):

Channel1	Type1	Data1	Channel2	Type2	Data2	Channel 3	...
1 Byte	1 Byte	N Bytes	1 Byte	1 Byte	M Bytes	1 Byte	...

For decoder examples you can find them at <https://github.com/Milesight-IoT/SensorDecoders>.

5.1 Basic Information

WS136 & WS156 report basic information of panel whenever joining the network.

Channel	Type	Description
ff	01(Protocol Version)	01=> V1

	09 (Hardware Version)	01 40 => V1.4
	0a (Software Version)	01 14 => V1.14
	0b (Power On)	Device is on
	16 (Device SN)	16 digits

Example:

ff0bff ff0101 ff166592b32851010013 ff090100 ff0a0102					
Channel	Type	Value	Channel	Type	Value
ff	0b (Power On)	ff (Reserved)	ff	01 (Protocol Version)	01 (V1)
Channel	Type	Value	Channel	Type	Value
ff	16(Device SN)	6592b328510 10013	ff	09 (Hardware version)	0100 (V1.0)
Channel	Type	Value			
ff	0a (Software version)	0102 (V1.2)			

5.2 Button Message

WS136 & WS156 reports battery level according to reporting interval (1080 mins by default) and button message when button is pressed.

Channel	Type	Description
01	75(Battery Level)	UINT8, Unit: %
ff	34(Button Message)	Byte 1: Button Number Byte 2-3: Button LoRa D2D Command, the command is 01-06 by default.

Example:

01 75 64		
Channel	Type	Value
01	75 (Battery)	64 => 100%

ff 34 01 18 00		
Channel	Type	Value
ff	34(Button Message)	01 => Button 1 18 00=>This button LoRa D2D command is 0018

Note: if you press one button more than 6 times in a row, the 7th and follow-up messages will delay delivery.

5.3 Downlink Commands

WS136 & WS156 supports downlink commands to configure the device. Application port is 85 by default.

Note: Since the device type is class A, it only receives downlinks when the device upload battery level or button message to network server.

Channel	Type	Description
ff	03 (Set Reporting Interval)	2 Bytes, unit: s
	35 (Set LoRa D2D Key)	8 Bytes, other bytes are fixed as 0.
	36 (Set LoRa D2D Spreading Factor and Frequency)	Byte 1: Spreading factor Byte 2-3: Frequency, unit: Hz

Example:

1. Set reporting interval as 20 minutes.

ff03b004		
Channel	Type	Value
ff	03 (Set Reporting Interval)	b0 04=>04 b0=1200s =20 minutes

2. Set LoRa D2D key as 12345678123456780000000000000000.

ff351234567812345678		
Channel	Type	Value
ff	35 (Set LoRa D2D Key)	12 34 56 78 12 34 56 78

3. Set LoRa D2D spreading factor as DR5(SF7) and frequency as 505.7 MHz.

ff3605a05e241e		
Channel	Type	Value
ff	36 (Set LoRa D2D Spreading Factor and Frequency)	Byte 1: 05 (DR5) Byte 2: a0 5e 24 1e => 1e 24 5e a0=505700000 Hz (505.7 MHz)

-END-