Wireless 2-Input Dry Contact Interface

Wireless Sensor Network Based on LoRa Technology



R718J2

Data Sheet

Copyright©Netvox Technology Co., Ltd.

This document contains proprietary technical information which is the property of NETVOX Technology. It shall be maintained in strict confidence and shall not be disclosed to other parties, in whole or in part, without written permission of NETVOX Technology. The specifications are subject to change without prior notice.

Wireless 2-Input Dry Contact Interface

Introduction

Netvox wireless 2-Input dry contact sensors can be used to detect contact between two wired contact points. This sensor can be used with an external mechanical switch or a contact plate to alert the user via APP when the contacts touch or a switch is triggered.

Main Characteristic

- Adopt SX1276 wireless communication module
- Compatible with LoRaWAN™ Class A
- Improved interference immunity
- Encrypt-RF™ Security (Diffie-Hellman Key Exchange + AES-128 CBC for sensor data messages)
- The base is attached with a magnet that can be attached to a ferromagnetic material object
- Frequency hopping spread spectrum (FHSS)
- Configuration parameters can be configured through third-party software platforms, data can be read and alarms can be set via SMS text and email (optional)
- Applicable to the third-party platforms: Actility/ThingPark, TTN, MyDevices/Cayenne
- Low power consumption and long battery life

Note:

Battery life is determined by the sensor reporting frequency and other variables, please refer to http://www.netvox.com.tw/electric/electric_calc.html

On this website, users can find battery life of various models in different configurations.

Wireless 2-Input Dry Contact Interface

Application

- Tamper switches
- Barn door access monitoring
- Freezer/ cooler door access
- Freezer/ cooler doors (to determine if they are not closed all the way)
- Convenience store cooler doors (to determine if they are not closed all the way)
- Forklift seat switches
- Dry contact switches

Dimension

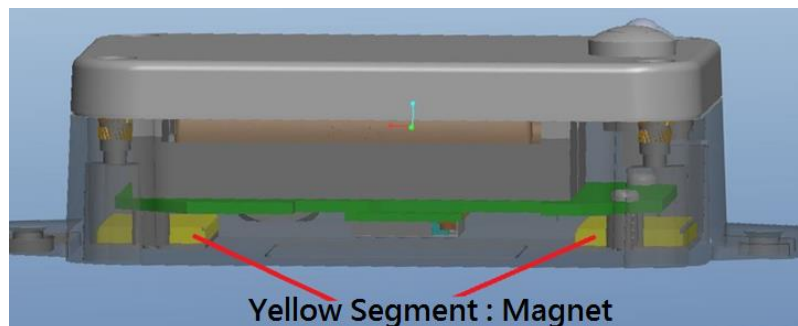
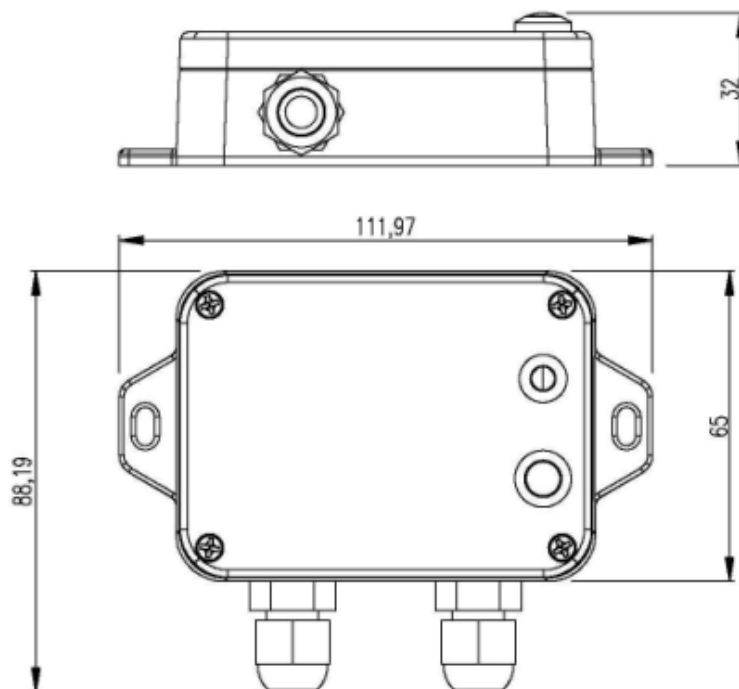

Wireless 2-Input Dry Contact Interface

Figure 2 Dimensions of main engine shell

Electric

Input Power	2 x 3.6V ER14505 AA lithium batteries (3.6V 2400mah/section)
Standby Current	22uA
Wakeup Current	6.3mA/ 3.3V
Transmitting Current (max)	120mA/ 3.3V
Receiving Current (max)	11mA/ 3.3V
Battery Measurement Accuracy	± 0.1V
Low Voltage Threshold	3.2V

External Wire Characteristics

Wire material	UL2547 28AWG
Wire temperature (max)	80°C
Wire outer diameter (max)	2mm
Wire length	1000mm (±5mm)
Wire flame resistance rating	VW-1

Frequency

Frequency Range	863MHz-928MHz 470MHz-510MHz
TX Power	US915 20dbm; AS923 16dbm; AU915 20dbm; CN470 19.15dbm; EU868 16dbm; KR920 14dbm; IN865 20dbm;
Receiving Sensitivity	-136 dBm (LoRa, Spreading Factor=12, Bit Rate = 293bps) -121 dBm

Wireless 2-Input Dry Contact Interface

	(FSK, Frequency deviation=5kHz, Bit Rate=1.2kbps)
Antenna Type	Build-in antenna
Communication Distance	10 km (Visible linear obstacle-free transmission distance, actual transmission distance depending on the environment.)
Data Transfer Rate	0.3kbps ~ 50kbps
Modulation	LoRa / FSK (Note: choose one of them)
Supportable LoRaWAN Frequency	EU863-870, US902-928, AU915-928, KR920-923, AS923, CN470-510 (Note: The frequency band is optional and needs to be configured before shipment.)

Physical

Dimension	L: 112 mm x W: 88.19 mm x H: 32 mm
Weight	150g
Environment Humidity Range	<90 %RH (No condensation)
Operating Temperature	-20°C to 55 °C
Storage Temperature	-40°C to 85 °C