Wireless 2-Gang Water Leak Detector

Wireless 2-Gang Water Leak Detector R718WA2 Data Sheet

Wireless Sensor Network Based on LoRa Technology



R718WA2

Copyright©Netvox Technology Co., Ltd.

This document contains proprietary technical information which is the property of NETVOX Technology. It shall be maintained in strict confidence and shall not be disclosed to other parties, in whole or in part, without written permission of NETVOX Technology.

The specifications are subject to change without prior notice.

Wireless 2-Gang Water Leak Detector

General Description

This device is an alarm device for 2-way leak detection. When the water sensor detects a leak, it will send an alarm message to the gateway. When the water sensor detects that there is no water leak again, it will send a back to normal status message to the gateway, which uses the SX1276 wireless communication module.

Main Characters

- Apply SX1276 wireless communication module
- 2 section ER14505 batteries AA SIZE (3.6V/section) parallel power supply
- Base with magnet attached to iron objects

Example Applications

- Engine Room
- Warehouse
- Smart Home
- Archives
- Air Conditioning
- Semiconductor Plant
- Data Center

Features of NETVOX Sensors

- LoRaWAN™ Class A compatible
- Frequency Hopping Spread Spectrum (FHSS)
- Improved interference immunity
- Improved power management for longer battery life
- Encrypt-RF™ Security (Diffie-Hellman Key Exchange + AES-128 CBC for sensor data messages)
- Battery Life*2:

Please refer to web: http://www.netvox.com.tw/electric/electric_calc.html

At this website, users can find battery life time for varier models at different configurations.

- Over-the-air updates (future)
- Third-Party online wireless sensor monitoring and notification system to configure sensors, view data and set alerts via SMS text and email (optional)
- Available third-party platform: Actility/ThingPark, TTN, MyDevices/Cayenne
- R718X series carry magnets which can be attached to ferromagnetic materials and objects

*1. Actual range may vary depending on environment.

*2. Battery life is determined by sensor reporting frequency and other variables

Wireless 2-Gang Water Leak Detector

Technical Specifications

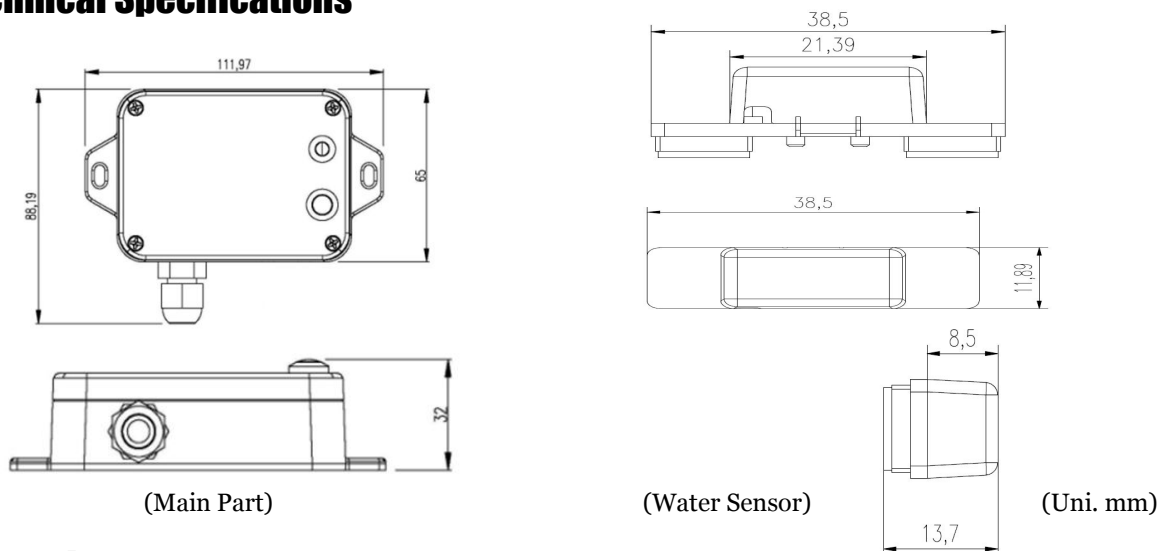

Electric

Input Power	2 x 3.6V ER14505 AA lithium batteries (3.6V2400mah/section)
Sleeping Mode	23uA
Wake up Mode	6.3mA@3.3V
Low Voltage Threshold	3.2V
Receiving Current (max)	11mA @3.3V
Transmitting Current (max)	120mA/3.3V
Battery Voltage Measurement Accuracy	±0.1V

* Specific electrical characteristics may vary depending on the power supply voltage.

Water Sensor

Water Line Material	UL2547 28AWG
Water Line Max. Working Temperature	80 ° C
Water Line Diameter	2mm
Water Line Length	1000mm (±5mm)
Water Line Flame Resistance Rating	VW-1
Water Line Length Limit	300m (theoretical value)
Water Sensor Size	L: 38.5 mm*W: 11.9 mm*H: 13.7 mm

Wireless 2-Gang Water Leak Detector

Frequency

TX Power	19dBm±1dBm
Rx Sensitivity	-136dBm (LoRa, Spreading Factor=12, Bit Rate=293bps) -121dBm (FSK,Frequency deviation=5kHz, Bit Rate=1.2kbps)
Antenna Type	Build-in antenna
Communication Range	Up to 10 km, the actual transmission distance depends on the environment.
Data Transfer Rate	0.3kbps~50kbps
Spread Technique	LoRa/FSK
Available Frequency	EU863-870, US902-928, AU915-928, KR920-923, AS923, CN470-510 Configured before shipment

Physical

Dimension	Main Part: L: 112mm*W: 65mm*H: 32mm
Weight	151g
Environment Temperature Range	-20℃ ~ 55℃
Environment Humidity Range	<90% RH (No condensation)
Storage Temperature	-40℃ ~ 85℃

Contact:**NETVOX TECHNOLOGY CO., LTD.****TEL: 886-6-2617641****FAX: 886-6-2656120****E-mail: sales@netvox.com.tw****WEB: www.netvox.com.tw****NETVOX TECHNOLOGY CO., LTD (XIAMEN)****TEL: 86-592-5717188****FAX: 86-592-5717180****E-mail: dyx@netvox.com.cn****WEB: www.netvox.com.cn**