

Nexelec



D974B_Technical guide

ORIGIN+ ORIGIN GUARD+ GUARD

LORAWAN

05/12/2023

I. PRODUCT OVERVIEW	4
1. Main functionalities.....	4
2. Product scheme.....	5
3. Set contents	6
4. Product terms of use and certifications.....	6
5. Support and integration tools	7
II. PRODUCT INSTALLATION	7
1. Installation sites.....	7
2. Detector mounting	9
3. Anti-tear detection	11
4. Product commissioning	11
– 01. Origin / Origin + products	11
– 02. Guard / Guard+ products	11
– 03. Automatic network connection	12
III. MAIN BUTTONS AND LEDS	13
– 01. Short press	13
– 02. Long press to test your product	13
– 03. Product maintenance	14
IV. REVERSE BUTTONS AND LEDS	15
V. PRODUCT OPERATION – NORMAL MODE	16
VI. INTERCONNECTION WITH DAAF AND ACCESSORIES	17
1. Interconnection network creation.....	17
2. Add a product in the network	18
3. Unpairing	18
VII. PRODUCT OPERATION – SPECIFIC FEATURES TO INTERCONNECTED MODE	19
1. Smoke detection.....	19
2. Main push button	20
– 01. Short press	20
– 02. Long press	21
VIII. AIR QUALITY ANALYSIS	22
IX. NFC ACCESS TO TEMPERATURE/HUMIDITY MEASUREMENTS	22
X. AUTONOMY	23
1. Remaining lifetime forecast	23
2. Estimating my product’s autonomy.....	23
3. Factors influencing product autonomy.....	23

— 01.	Data transmission frequency	23
— 02.	LoRaWAN network coverage quality	24

XI. LORAWAN PARAMETERS **24**

1.	Recommended LoRaWAN parameters	24
2.	Network connection	24
— 01.	Automatic commissioning on power-up	24
— 02.	Commissioning strategy in case of initial failure	24
— 03.	Schedule a recommissioning	25
— 04.	Periodic check of the network connection	25
3.	Description of data transmission modes	25
— 01.	Daily air quality	25
— 02.	Temperature datalog	25
4.	General description	27
— 01.	Product status	27
— 02.	Configuration of product function	28
— 03.	Smoke alarm status	30
— 04.	Daily air quality	31
— 05.	Periodic Data	32
— 06.	Temperature datalog	32

XII. PRODUCT CONFIGURATION AND REMOTE COMMANDS **34**

1.	Configurations for temperature/humidity transmission	34
2.	Configurations for product maintenance, reliability and security	34
3.	Configurations related to interconnection	35

XIII. PRODUCT RECONFIGURATION VIA DOWNLINK MESSAGE **35**

1.	Reconfiguration acknowledgment	35
2.	Downlink message structure	35

XIV. NFC CONFIGURATION **37**

1.	NFC antenna location	37
2.	Application download	38
3.	Access to TOUCH Android application documentation	38

XV. TRACEABILITY AND MARKINGS **38**

XVI. REVISION HISTORY **39**

I. Product overview

1. Main functionalities

This document describes the technical operation of the LoRaWAN-connected, interconnected, NFC-configurable smoke detector. The range comprises 4 products, depending on the temperature/humidity sensor integration and the power source (sealed or replaceable battery).

Model	Name	T°/Hum	Power	
			Sealed batteries	Replaceable battery
X870LS	Origin+	●	●	
X865LS	Origin		●	
X860LS	Guard+	●		●
X855LS	Guard			●

This guide is common to all products. Depending on your product, the dedicated sections may not be applicable.



Electronic maintenance certificate	Interconnection	Reliable data transmission	Temperature/Humidity
After each maintenance operation, a unique certificate is recorded in the detector's secure NFC chip	Up to 25 interconnected sensors and accessories	Transmission mode adapted to every need, with redundant transmissions for high availability of critical data	For a better indoor comfort. Measures home environment parameters



Powerful audible alarm
85 dB at 3 metres to quickly alert occupants



Air 360°
Exclusive detection technology. Simplifies maintenance by residents

TEST

Test/Silence button
Large, easy-to-reach touch button on front panel



Silence function
Stops the alarm and/or puts the detector on standby for 10 minutes without removing it from its base



Compact mounting base
Only 3 cm in diameter to avoid damaging the installation surface



Insect barrier
Pest protection grid integrated into the detector



Signal light
Discreet LED indicator in standby mode, powerful in alarm mode



Calibration certificate
Temperature and humidity measurement accuracy validated by an accredited metrology laboratory



8-hour beep delay
Temporarily silences fault beeps until detector is replaced



Remote surveillance compatible⁽¹⁾
To report fire alarms, remove doubts or request on-site intervention by an approved company

2. Product scheme

DIMENSIONS & WEIGHT



150 g (including battery and stand)

3. Set contents

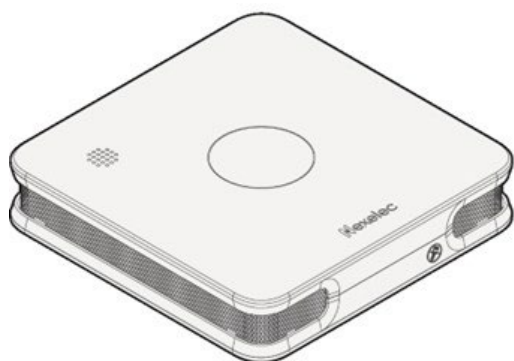

1x Detector

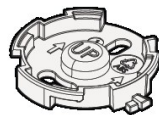

1x BASE / BASE+
mounting base

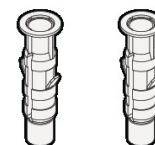
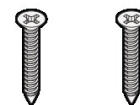

2x nylon screws
and plugs

4. Product terms of use and certifications

CONDITIONS OF USE

> Indoor household environment

> Temperature: -10°C to + 65°C

Note: The detectors have a lifespan of 10 years in a standard domestic environment (temperature between 15 ° C and 30 ° C). The detectors can be used in an exceptional domestic environment (temperature between -10°C and 65°C). Recurring and / or prolonged use in this exceptional environment can reduce battery life and therefore detectors autonomy. Residual battery estimation may also be wrong outside standard domestic environment.

> Relative humidity: from 0 to 99% RH (non-condensing)

CERTIFICATIONS

Applicable certifications and associated declarations of conformity are available on the Nexelec support website support.nexelec.fr

5. Support and integration tools

Documentation and tools for this product can be found on our website support.nexelec.fr

Here you'll find :

- > CODEC, Javascript code for decoding LoRaWAN messages:
<https://support.nexelec.fr/fr/support/solutions/folders/80000678871>
- > Online decoding tool for LoRaWAN messages :
<https://nexelec-support.fr/n/decoder/>
- > Online downlink calculation tool for remote product reconfiguration:
<https://nexelec-support.fr/n/downlink/>
- > VOTL: Online product autonomy calculator :
<https://nexelec-support.fr/n/volt/>

If you have any questions, our support team can be contacted by e-mail at support@nexelec.fr

II. Product installation

1. Installation sites

Depending on the layout and the surface area of the dwelling, several smoke detectors may be required to ensure minimum protection and guarantee efficient detection, the range of the alarm and quick evacuation of the dwelling.



STANDARD INSTALLATION

- > One detector per floor
- > In hallways and/or stairwells
- > Between rest areas (bedrooms), the possible ignition sources (garage, area with a high electrical system, etc.) and exits leading outside of your home (door, window)

RECOMMENDED PLACES

Place a detector:

- > One detector per floor
- > One detector per corridor
- > One detector per stairwell
- > In each room (1 for 50 m²), except in the kitchen and the bathroom (refer to paragraph below: «Places to be avoid»)

It is recommended to install smoke detectors:

- > Close to possible ignition sources
- > less than 7 m from rest areas (3 m if the doors are closed)
- > less than 7 m from exits

Locate the detector in line with the current building standards.

PLACES TO AVOID

Do not install the smoke detector:

- > Outside
- > In a place where the alarm will be difficult to hear (room with closed door)
- > In a place where the detector will be difficult to reach, in particular to perform tests
- > In a place where the temperature is lower than -10°C or higher than 50°C
- > In a place where humidity is less than 10% or exceeds 95% (bathroom, kitchen, laundry room, etc.)
- > In a place subject to high and/or rapid temperature, pressure or humidity variations
- > In a place where the sunlight hits directly on the detector
- > In a dusty or dirty area (garage, workshop, etc.)
- > In insect-infested areas
- > In a place where spurious smoke may disturb the smoke detector: kitchen, chimney, garage (exhaust gas), furnaces, boiler rooms, combustion radiators, etc.
- > Close to heating appliances, windows, ventilation ducts, air conditioners, fans or any other item of equipment that may produce air flows
- > Close to an area that is hotter or cooler than the rest of the room (non-insulated walls, hatches, etc.)
- > Less than 50 cm from obstacles preventing the smoke from accessing the detector (decorative objects, walls, doors, plants, chandeliers, curtains, etc.)
- > Less than 50 cm from lighting appliances (ceiling light, incandescent lamps, halogen or fluorescent lamps, etc.)
- > Less than 1.5 m from electrical appliances or their wiring

CEILING MOUNTING

Install the detector on the ceiling in the center of the room, at least 50 cm from corners, walls, beams or any other obstacles.

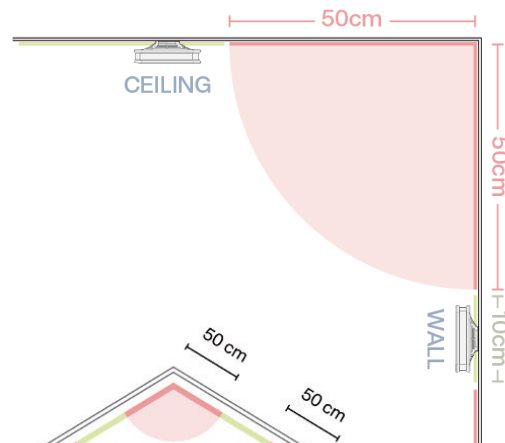

WALL MOUNTING

Install the detector to the wall at a distance of between 50 cm and 60 cm from the ceiling.

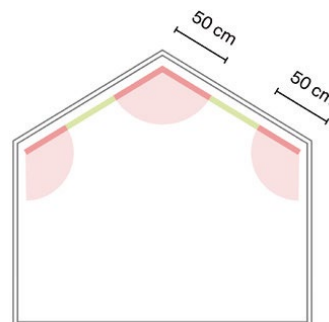

MOUNTING ON A SLOPED CEILING

Install the detector more than 50 cm from any corner of the room

2. Detector mounting

Choose a suitable location for mounting the detector:

- > On the ceiling or wall for ORIGIN and GUARD
- > On the wall for ORIGIN+ and GUARD+ (to have valid temperature/humidity measures)

FITTING THE BASE/BASE+ BASE WITH SCREWS AND PLUGS

To secure the base to the wall or ceiling:

- > Use a level to draw a 5 cm line on the wall
- > Position the base on the line with the “UP” marking and arrows pointing upwards. The small ears on either side of the base should be on the lower edge of the line
- > Mark the screw holes with a pencil, then drill the holes
- > Insert the nylon plugs supplied and screw on the mounting base

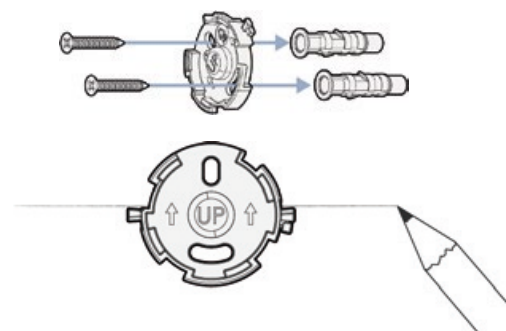

FITTING THE BASE/BASE+ BASE WITH FIX ADHESIVE FASTENER (OPTIONAL)

FIX adhesive fasteners are to be used exclusively with BASE and BASE+ bases. They are not supplied with the product, and are available as accessories.

- > Place the adhesive on the base and press firmly with your fingers for 10 seconds
- > Remove the adhesive backing and stick the mounting base to the wall or ceiling
- > Press firmly with your fingers for 10 seconds and wait 30 seconds

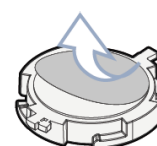

Place the detector on the mounting base, then turn it a quarter-turn to the right to secure it.

You should hear a “click”, indicating that the detector is secured to the base. Check that the detector is securely fixed to the wall or ceiling.

Warning - If the detector is fixed with the adhesive mount, do not turn it too much, as this may twist the mount.

Compatible mounting accessories: FIX, BASE, BASE+, TAPE, MOUNT, MOUNT+. Use of any accessory other than those listed above will invalidate product certification.

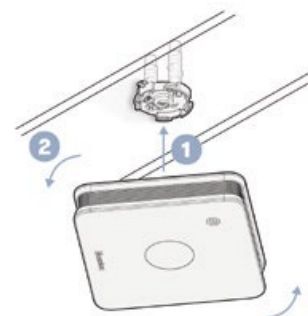

MOUNT / MOUNT+ BASE INSTALLATION WITH SCREWS AND PLUGS (OPTIONAL)

The MOUNT base can be installed on existing wall plugs, so there's no need to drill new holes in the base. It is ideal for replacing older smoke detectors.

To secure the base to the wall or ceiling:

- > Use a level to draw a 5 cm line on your wall
- > Position the base on the line with the “UP” marking and arrows pointing upwards. The 3 cm hole in the center of the detector should be on the line.
- > Mark the screw holes with a pencil, then drill the holes
- > Insert the nylon plugs supplied and screw on the mounting base

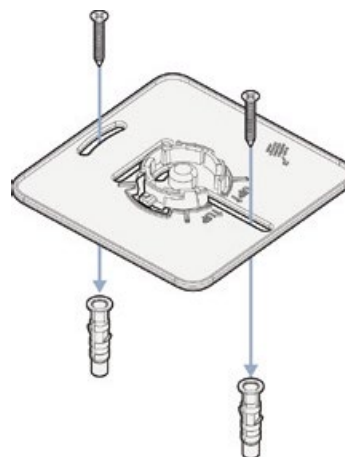
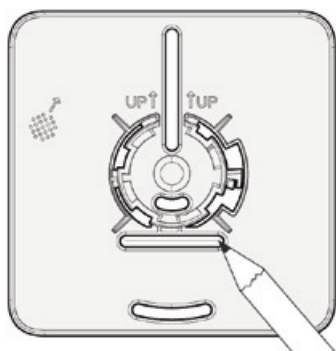

MOUNT / MOUNT+ BASE INSTALLATION WITH TAPE ADHESIVE FASTENER (OPTIONAL)

TAPE adhesive fasteners are to be used exclusively with MOUNT and MOUNT+ bases. They are not supplied with the product, and are available as accessories.

- > Place the adhesive on the mounting base and press firmly with your fingers for 10 seconds
- > Remove the adhesive backing and stick the mounting base to the wall or ceiling
- > Press firmly with your fingers for 10 seconds and wait 30 seconds



Place the detector on the mounting base, then turn it a quarter-turn to the right to secure it. You should hear a “click”, indicating that the detector is secured in its base. Check that the detector is securely fastened to the wall or ceiling.

Warning - If the detector is fixed with the adhesive mount, do not turn it too much, as this may twist the mount.

Compatible mounting accessories: FIX, BASE, BASE+, TAPE, MOUNT, MOUNT+. Use of any accessory other than those listed above will invalidate product certification.

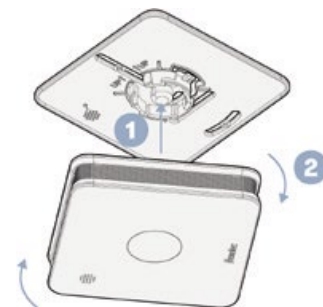

3. Anti-tear detection

The product is fitted with a magnet to check whether the product is installed on its mounting base or not. This function ensures that products have not been removed from their base. As soon as the product is inserted or removed from its base, a LoRaWAN “Product Status” message is transmitted.

4. Product commissioning

— 01. Origin / Origin + products

To commission your monitor, turn on single-purpose switch located at the rear of the product (1).

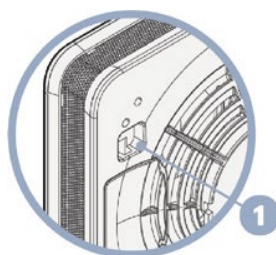

— 02. Guard / Guard+ products

Guard and Guard+ product are automatically commissioned by inserting the battery (2). Make sure to press the tab downwards with the negative side of the battery.

Recommended compatible batteries: CR17335EG-ZZ6 (FDK) or CR123A-R (VARTA)

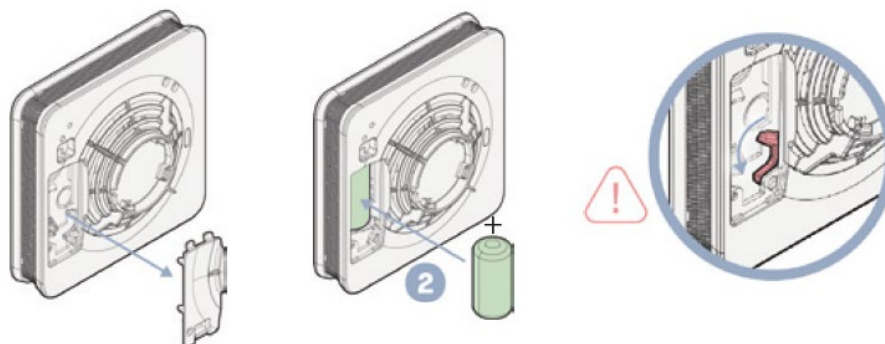

Warning – If the recall tab is not held down by the battery, it will be impossible to close the battery door.

— 03. Automatic network connection

Once powered, the product:

- > Initializes for approx. 5 seconds: steady reverse orange LED
- > Attempts to connect to the LoRaWAN network on:
 - Detection of a magnet base
 - After a short press on the bottom button
 - 30 seconds after powering the product if necessary

The reverse LED displays the stages of the product initialization and connection phase:

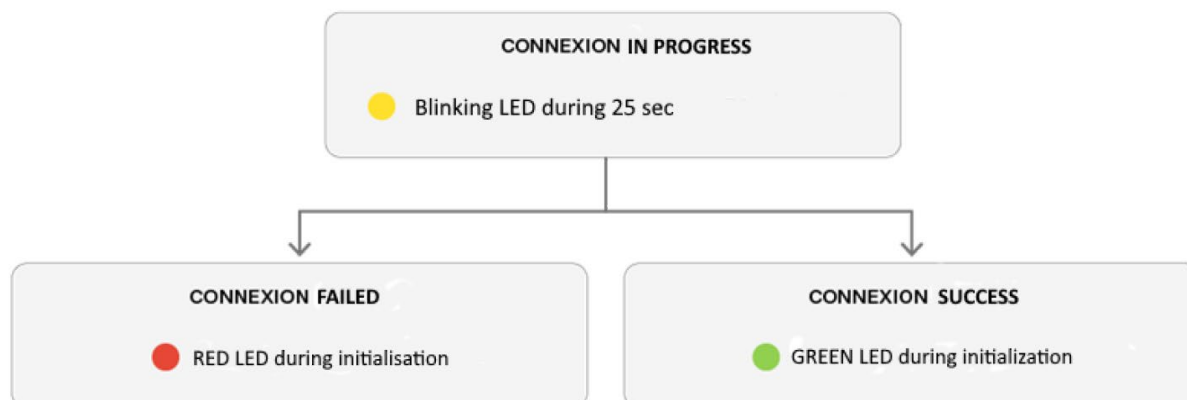

At the end of the connection phase (approx. 30 seconds), the product is ready for use. In the event of failure, the product will immediately attempt a second connection to the network and then periodically (more information is available in section XI.2. Network connection).

III. Main buttons and LEDs

The main button is located on the front of the product.

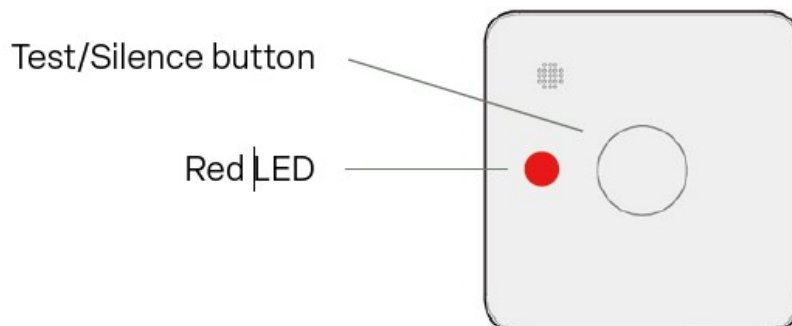

Mode	Support type	Action generated	Reverse LED
Normal	Long press	<ul style="list-style-type: none"> Manual test Remote/local network status indication (*) 	2 successive flashes of the LED, repeated 5 times:
			●● LoRa OK, Interconnection OK
			●● LoRa OK, Interconnection NOK
			●● LoRa NOK, Interconnection OK
Alarm	Short press	<ul style="list-style-type: none"> Alarm paused during 9 minutes 	/
Low battery default	Short press	<ul style="list-style-type: none"> Low battery default paused during 8 hours 	/

* Local network : LoRa connection
 Remote network : Connection to accessories

— 01. Short press

Short press is used for pausing or stopping the smoke alarm. Pausing the alarm helps to control a pending false alarm in advance (e.g.: smoke or steam when cooking, use of candles or incense, cigarette smoking, etc.). After 9 minutes, your product automatically resumes normal operation.

— 02. Long press to test your product

To test your alarm, press the button (> 3 seconds) until the alarm sounds then release. If the test does not work, the detector probably detected an operating defect.

A LoRa “Smoke alarm” message is sent to indicate a test has been done (Refer to section XI.4.3. Smoke alarm status).

Specific to ORIGIN + and GUARD+ products

“Periodic data” message containing temperature and humidity is also generated (Refer to section XI.4.5. Periodic data). Temperature and humidity data measured after a product test are also available in NFC.

— 03. Product maintenance

The product must be dusted every year to ensure correct operation. To do this:

- > Remove the product from its base
- > Clean it
- > Place it back on its base
- > Press the main button (> 3 seconds) until the alarm sounds then release

A LoRa “Smoke alarm” message is sent to indicate a test has been done (Refer to section XI.4.3. Smoke alarm status). If the product is equipped with a BASE+ or MOUNT+ base:

- The “Maintenance” field is set in the LoRa “Smoke Alarm” message.
- A flag is set to 1 in the NFC interface to indicate a product maintenance has been done. This flag is reset after 24h.

Specific to ORIGIN + and GUARD+ products

“Periodic data” message containing temperature and humidity is also generated (Refer to section XI.4.5. Periodic data). Temperature and humidity data measured after a product test are also available in NFC.

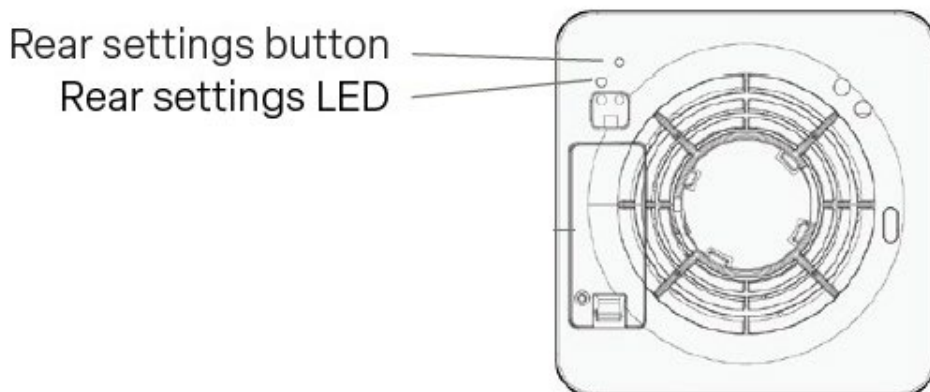

IV. Reverse buttons and LEDs

The secondary button is located at the rear of the product. An object (pen, paper clip, etc.) is required to activate the button. The sequence of actions induced by the use of the reverse button can be observed on the reverse LED, located next to the reverse button.



	Actions generated	Reverse LED
Short press	Manual attempt to connect to LoRaWAN network (Join)	Flashing ● : Connection attempt in progress ● : Successful connection ● : Failed connection
Triple press	DAAF or accessory pairing	● : DAAF or accessory pairing in progress ● : Successful DAAF or accessory pairing ● : Failed DAAF or accessory pairing
Long press	DAAF or accessory unpairing	● : Successful DAAF or accessory unpairing ● : Failed DAAF or accessory unpairing

V. Product operation – Normal mode

	Test/Silence Button			
Test	Press the Test / Silence button until the alarm signal sounds, then release	1 Flash several times per second	Audible alarm signal	OPERATIONAL after 10 minutes
Pause alarm	Briefly press the Test / Silence button	1 flash every 10 seconds for about 10 minutes		OPERATIONAL after 10 minutes
Alarm stop	Briefly press the Test / Silence button	1 flash every 10 seconds for about 10 minutes		OPERATIONAL after 10 minutes
Low battery warning		1 Flash every 45 seconds for at least 30 days	1 Bip toutes les 45 secondes pendant 30 jours minimum	NON-OPERATIONAL
Pause Low battery warning	Briefly press the Test / Silence button	1 Flash every 45 seconds for about 8 hours		NON-OPERATIONAL
End-of-life			3 beeps every 45 seconds	NON-OPERATIONAL
Default		1 Flash every 45 seconds	3 beeps every 45 seconds	NON-OPERATIONAL

Product is working locally as a standalone smoke alarm by activating its sounder and LED when smoke is detected.

A LoRa “Smoke Alarm” message (Refer to section XI.4.3. Smoke alarm status) is sent twice at 20 seconds intervals after the smoke alarm activation occurs. Then, the message is sent once every 5 minutes until smoke alarm deactivation. This event will also trigger a message sent twice at 20 seconds intervals.

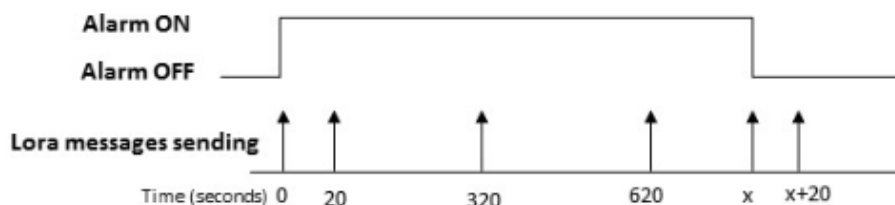

VI. Interconnection with DAAF and accessories

The detectors provide an interconnection function that allows to connect others detectors and accessories (e.g remote control, terminals). This function allows the alarm to be spread throughout a network of detectors and to be silenced remotely.

1. Interconnection network creation

ORIGIN+ / ORIGIN / GUARD+ / GUARD products

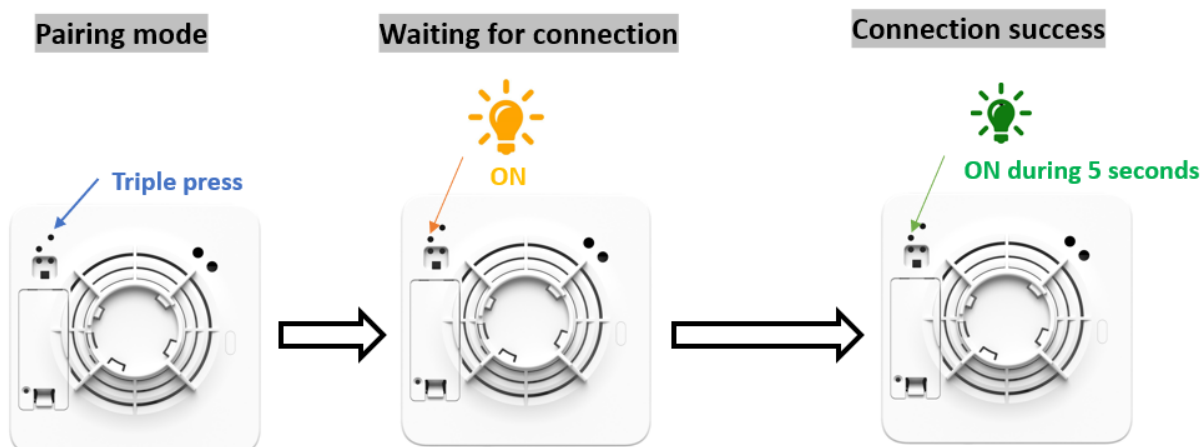

Accessory

Refer to the accessory manual to find out how to set it to pairing mode

- > Press the reverse button (3 times) of the detector to enter in pairing mode. The reverse orange LED will remain ON.
- > 2 different cases:
 - *Interconnection with another detector:* Press the reverse button (3 times) of the second detector to enter in pairing mode. The reverse orange LED will remain ON.
 - *Interconnection with an accessory:* Refer to the accessory manual to find out how to set it to pairing mode
- > After few seconds, the 2 devices entered in pairing mode, the reverse green LED of the detectors will remains ON during 5 seconds indicating the success of the pairing process. A product configuration message is sent twice with the corresponding network ID (Refer to section XI.4.2. Configuration of product function).

Note: The product automatically exits pairing mode after 5 minutes. To exit the pairing mode manually, press the bottom button (> 3 seconds).

It's also possible to connect a product via NFC TOUCH smartphone application or via downlink command.

2. Add a product in the network

- > On a product member of the network, press the bottom button (3 times). The bottom orange LED will remain ON.
- > On the product to be added, press the bottom button (3 times). The bottom orange LED will remain ON.
- > When the product successfully joins the existing network, the bottom green LED will remain ON during 5 seconds. A product configuration message is also sent twice with the corresponding network ID (Refer to section XI.4.2. Configuration of product function).

Note 1: The product automatically exits pairing mode after 5 minutes. To exit the pairing mode manually, do a long press on the bottom button.

Note 2: Products must be added one by one. Multiple products should not be added at the same time; the risk is to create several distinct networks.

3. Unpairing

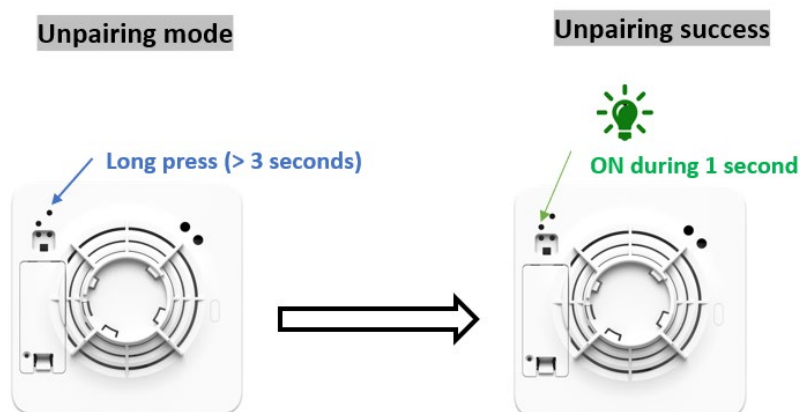

Press the reverse button (> 3 seconds) of the detector to disconnect it. The reverse green LED will remain ON during 1 second indicating the success of the unpairing.

It's also possible to disconnect a product via NFC TOUCH smartphone application or via downlink command.

VII. Product operation – Specific features to interconnected mode

Glossary for interconnected mode:

Detecting devices: products that detect smoke. Smoke detection triggers sounder and LED.

Repeating devices: products that repeat the alarm without detecting smoke. The red LED remains OFF as long as no smoke is detected.

1. Smoke detection

When smoke is detected by the product, this one activates its sounder and LED. All the products belonging to the same network also trigger their sounder within 1 minute (repeating devices).

As long as there is at least one detecting product in the network, the repeating alarms remain activated.

Example-

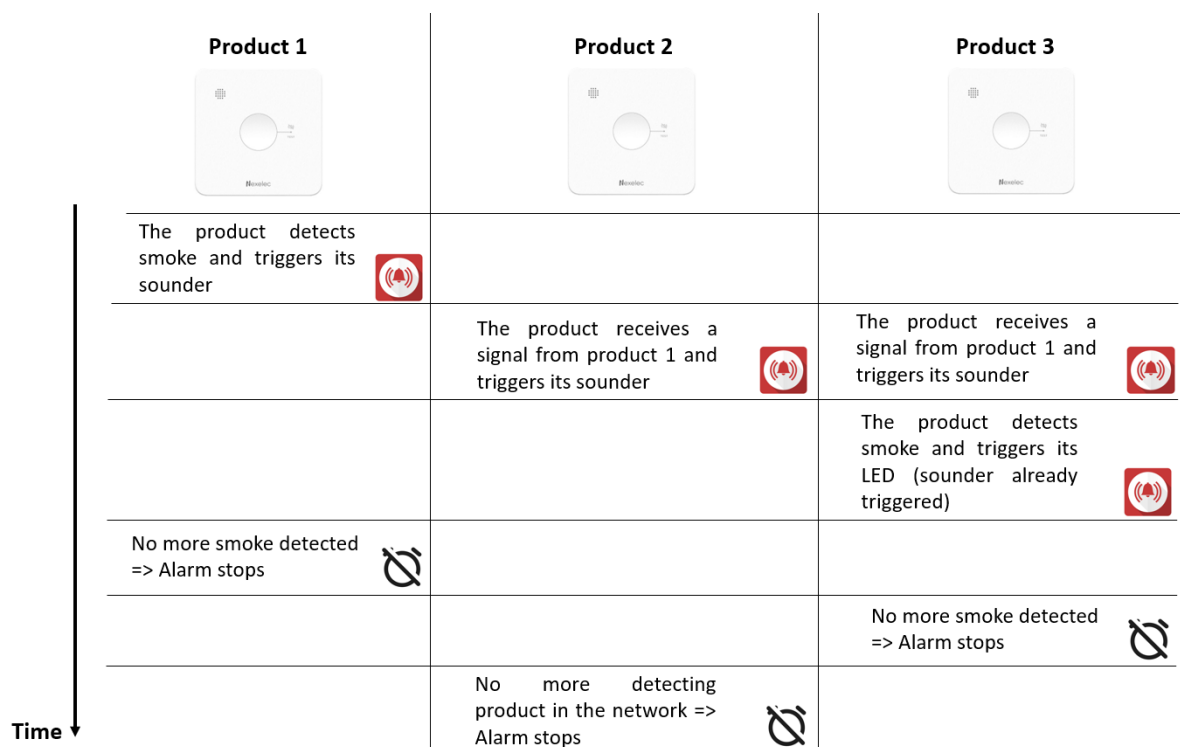

Detecting products send LoRa messages according to the same scheme as for the normal mode. Repeating products send a “Smoke Alarm” message after the smoke alarm activation occurs (Refer to section XI.4.3. Smoke alarm status). The smoke alarm deactivation will also trigger a message sent.

Note – The repeating alarms stop within 1 minute maximum after the end of the last detecting alarm.

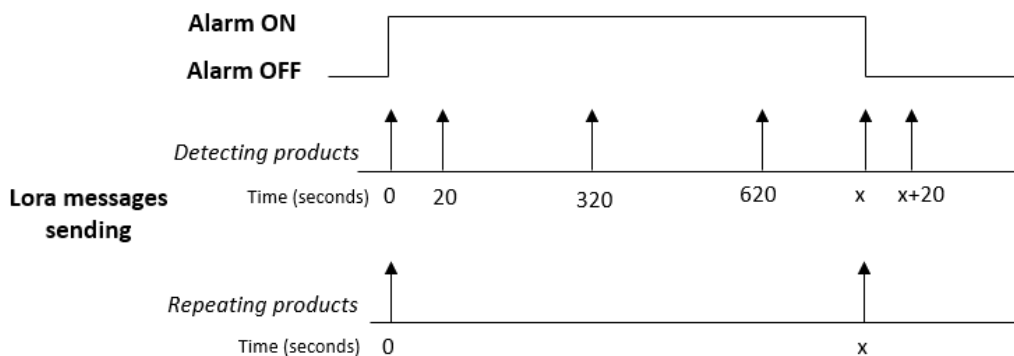

2. Main push button

— 01. Short press

PAUSE ALARM IN ADVANCE

Pressing the button only pauses the local smoke detection. Having paused a product won't avoid its alarm to be triggered if another product detects smoke in the network.

Example-

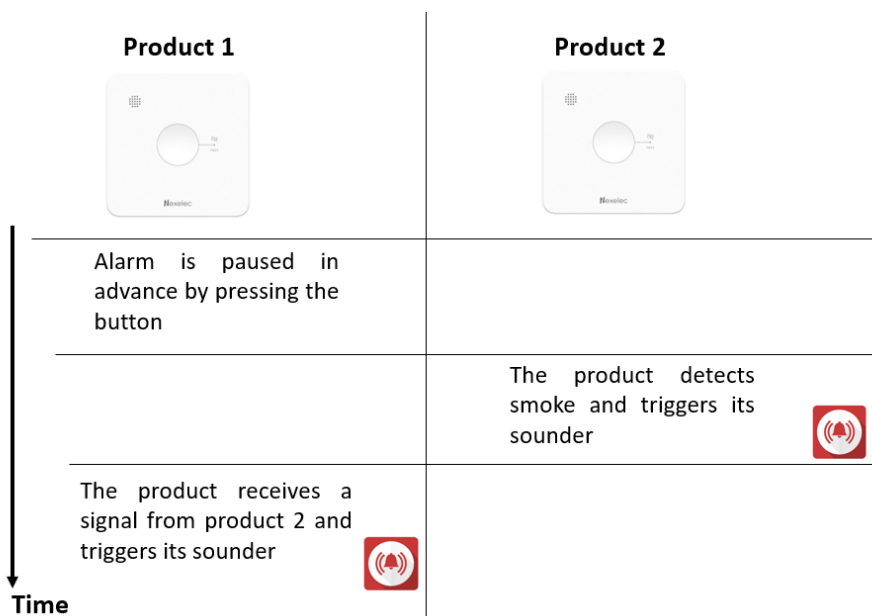

STOP ALARM ONCE ACTIVATED

Short press on a **repeating product** only stops its own smoke alarm.

Short press on a **detecting product** stops its own smoke alarm and the other alarms as long as there are no other detecting products in the network. To stop all the alarms, it's necessary to press the button of all detecting products.

Note – The repeating alarms stop within 1 minute maximum after the end of the last detecting alarm.

Example-

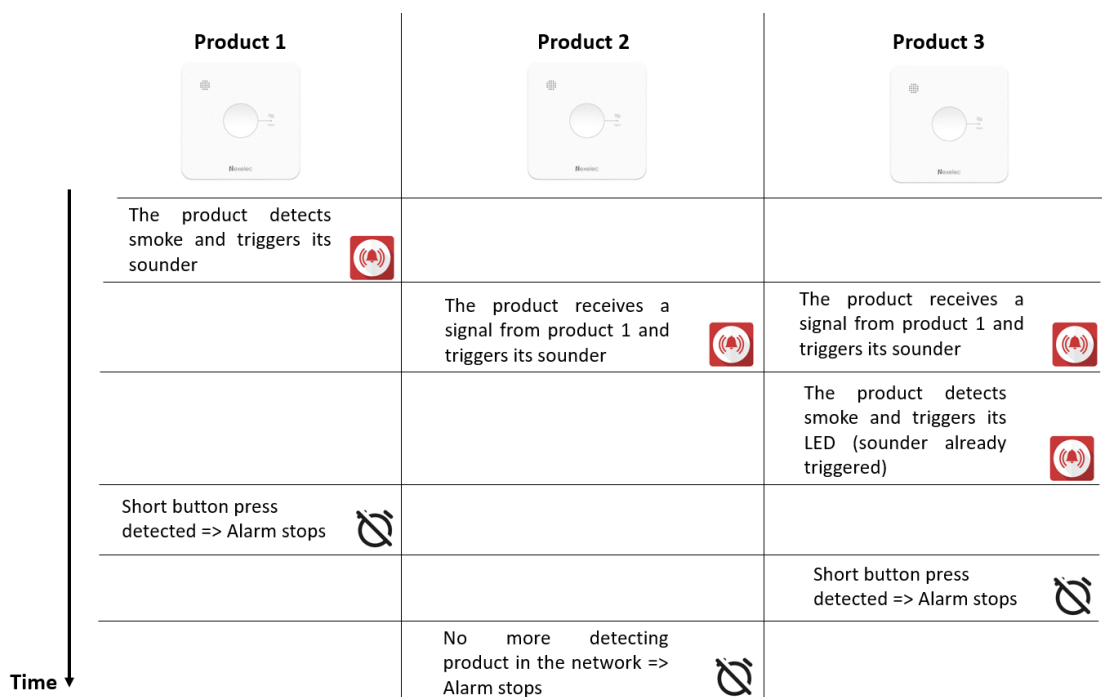

— 02. Long press

To test all the products in a network, press the button of a single product until all the alarms sound (within 1 minute maximum).

A LoRa “Smoke alarm” message is sent by all products to indicate a test has been done (Refer to section XI.4.3. Smoke alarm status).

Specific to ORIGIN + and GUARD+ products

“Periodic data” message containing temperature and humidity is also generated by the product on which the button has been pressed (Refer to section XI.4.5. Periodic data). Temperature and humidity data measured after a product test are also available in NFC.

Note – The repeating alarms stop within 1 minute maximum after the end of the detecting alarm.

VIII. Air quality analysis

ORIGIN+ and GUARD+ embeds a temperature/humidity sensor that enables air quality analysis. Depending on the use-cases, you can select the appropriate function to get temperature / humidity. More details are available on section XI.3. Description of data transmission modes).

Type	Unit	Range	Resolution	Precision		Measuring period
				Typ.	Max.	
Temperature	°C	-30 .. +70	0.1	±0.2 °C	±0.4 °C	10 minutes
Humidity	%RH	0 - 100	0.5	±2 %RH	±3 %RH	10 minutes

IX. NFC access to temperature/humidity measurements

This section is only valid for ORIGIN+ and GUARD+ products.

The data measured by the product (Temperature, humidity) can be consulted via the NFC TOUCH application. This function is particularly useful for :

- Viewing the current values of environmental parameters
 - Temperature
 - Relative humidity
- Viewing product status information
 - Status of sensors, battery etc.
 - Software and hardware version



To access data measured by the product via NFC:

- Long press on the product's main button (the product will launch a test and then measure environmental data)
- Use the NFC TOUCH smartphone application

X. Autonomy

ORIGIN and ORIGIN+ are powered by two non-chargeable and non-replaceable batteries. When batteries are empty, the product must be replaced. These products are designed for an autonomy of 10 years in their standard configuration.

GUARD and GUARD+ are powered with one replaceable battery. When the battery is empty, the battery must be replaced. These products are designed for an autonomy of 5 years in their standard configuration.

1. Remaining lifetime forecast

The product lifetime is 10 years. A countdown indicating the remaining time until product end of life is given in the product status frame (Refer to section XI.4.1. Product status, Remaining product lifetime field).

The connectivity autonomy part depends on the number of messages sent per days and the network coverage. The standard configuration of the product ensures a product lifetime of 10 years for ORIGIN and ORIGIN+ products and 5 years for GUARD and GUARD+ products (Refer to section XII.Product configuration and remote command).

2. Estimating my product's autonomy

An online calculation tool is available : <https://nexelec-support.fr/n/volt/>

It allows you to evaluate product autonomy according to transmission modes, network parameters. You can also access it by scanning the Qr Code:



3. Factors influencing product autonomy

— 01. Data transmission frequency

The product consumes energy when transmitting the data measured by the sensors. The lower the number of transmissions, the greater the product's autonomy.

— 02. LoRaWAN network coverage quality

LoRaWAN technology uses a mechanism called ADR, which adapts radio transmission parameters according to the level of network coverage. A product placed in an environment with very good radio coverage can consume up to 20 times less energy than a sensor placed in a less favorable environment. Your product's radio coverage is therefore a decisive factor in determining its autonomy.

XI. LoRaWAN parameters

1. Recommended LoRaWAN parameters

LoRaWAN protocol version : Product compatible with version 1.0.2

Regional parameters : Product compatible with parameters RP001 rev B

Profile: Class A (RX2SF9 or RX2SF12)

Available frequencies : EU868

Join type : OTAA

AppEUI : 0x70B3D540FA4A80ED

DevEUI : Unique identifier for each product. Information available on the label and provided on product delivery.

AppKey : Unique security key for each product. Information provided on product delivery.

Application port (uplink / downlink) : 56

ADR : Yes

2. Network connection

— 01. Automatic commissioning on power-up

When the device is switched on, 2 commissionings are launched on:

- > Detection of a magnetic base
- > After a short press on a the bottom button
- > 30 seconds after powering the product if necessary

If the process has been successful, the product will send its status (refer to section XI.4.1. Product status), its configuration (Refer to section XI.4.2. Configuration of product function) and a "Periodic data" message (Refer to section XI.4.5 Periodic Data).

— 02. Commissioning strategy in case of initial failure

If the initial commissioning process failed, the product will automatically try to join the network with an increasing period between each try:

1st retry will occur 20 minutes after initial commissioning.

2nd retry will occur 40 minutes after 1st try.

3rd retry will occur 80 minutes after 2nd try.

....

In case of failure, the product will then try to join the network every 24h.

— 03. Schedule a recommissioning

You can schedule a join request via a downlink command. The typical use case is when you want to switch from a server to another. A configuration message is sent twice to confirm the activation of the scheduling (Refer to section XI.4.1. Product status, “Pending Join” field set to 1).

It’s also possible to launch a join request via the NFC TOUCH smartphone application.

— 04. Periodic check of the network connection

The product checks its network connection every day by sending the “Product status” message via the standardized LoRaWan system “Linkcheck”. After 3 attempts without any answer from the network, the product will automatically try to join the network as described in the section “Commissioning strategy in case of initial failure”.

3. Description of data transmission modes

— 01. Daily air quality

This function measures temperature, humidity and air quality every 10 minutes.

Every day, it provides:

- Minimal, maximal and average temperature and humidity over 24h.

— 02. Temperature datalog

This function enables to gather several temperature measurements into a single LoRa message. This function enables to:

- > Reduce the number of messages sent by the product to increase the autonomy
- > Send the same data several times to reduce the potential loss of messages due to radio transmission.

The datalog mode integrates the “redundancy” function. It allows to repeat the transmission of a same measurement to maximize the chance of receiving the message.

The following parameters are used to configure datalog mode operation:

- > Number of new measures contained in a message
- > Message transmission period
- > Number of repetition of a same data (redundancy)

If this function is activated, the following parameters are applied by default:

- > Number of new measures in a message : 6
- > Message transmission period : 3 hours
- > Number of repetition of a same value : 3

Limit : In Europe, the LoRaWAN standard limits the maximum message size. It’s important to not exceed this limit, so make sure that the total number of measurements contained in a message doesn’t exceed 36. This total number corresponds to :

*Total number of measurements = number of new measurements * number of repetition of a same data*

Example: The following image illustrates the operation of the datalog function with the following parameters:

- > Number of new measures in a message : 12
- > Message transmission period : 6 hours
- > Number of repetition of a same value : 3

This configuration tells the product to store measurements with a time step of 30 minutes (12 new measurements transmitted every 6 hours) and to send them every 6 hours, integrating the same measurement 3 times. The number of measurements per message will be 36 (12 new measurements * 3).

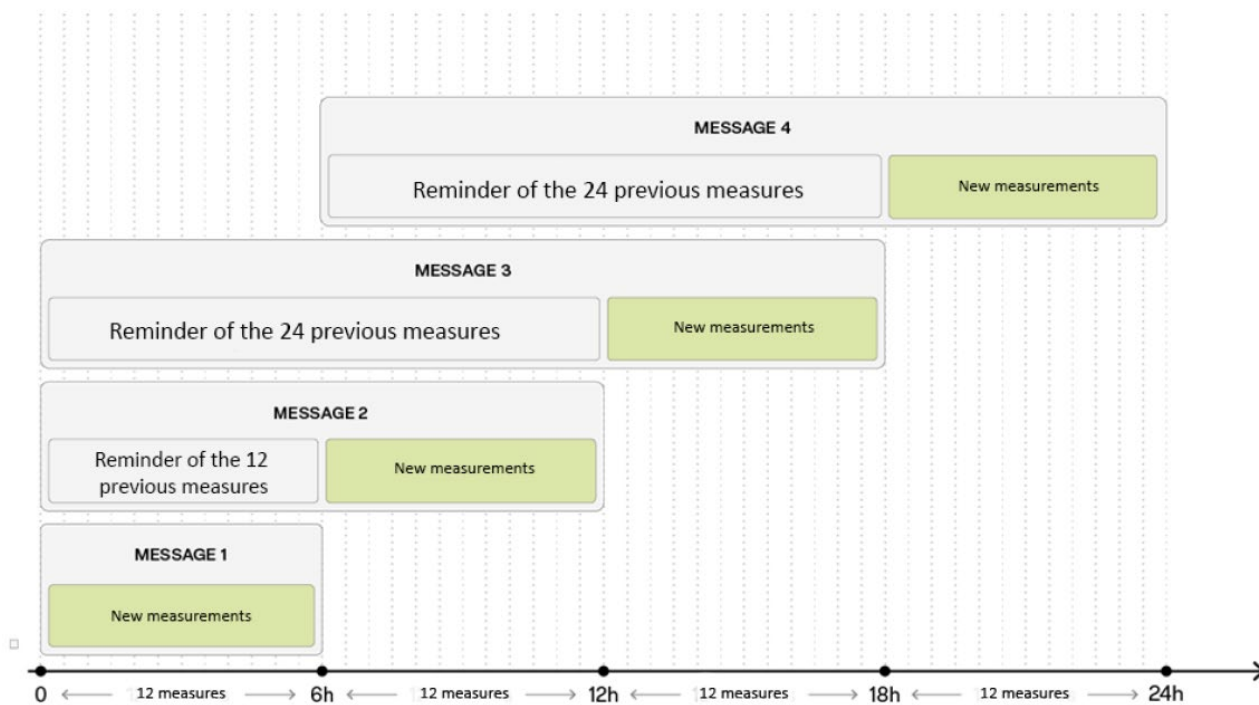

4. General description

The different types of messages are described below:

Details of the function	ID message	Transmission of message	Can be deactivated	Configurable
Product Status	0x00	On event + Periodic	No	No
Product Function Configuration	0x01	On event + Periodic	No	No
Smoke Alarm status	0x02	On event + Periodic	No	No
Daily air quality	0x03	Periodic	Yes	Yes
Periodic Data	0x04	On event + Periodic	No	No
Temperature Datalog	0x05	Periodic	Yes	Yes

— 01. Product status

This message is sent when product is powered on, every day or when one of this information changes:

- > Battery level indication is defined using 4 levels:
 - High level: More than 50% remaining battery capacity
 - Medium level: 20-50% remaining battery capacity
 - Low level: 1-10% remaining battery capacity
 - Critical level: Less than 1% remaining battery capacity
- > Product HW status: Smoke sensor status, Temperature/Humidity sensor status
- > Smoke sensor activation
- > Magnetic base detection

Offset	Size (bit)	Bit-range	Data	Description	Valid Range	Scale	Unit
0	8	DB0.7 – DB0.0	Type of product	Product model	ORIGIN+: 0xB1 ORIGIN: 0xB2 GUARD+: 0xB3 GUARD: 0xB4		
8	8	DB1.7 – DB1.0	Type of message	Product Status	0x00		
16	8	DB2.7 – DB2.0	HW revision	Hardware revision	1 - 255	1: V001 ... 255: V255	
24	8	DB3.7 – DB3.0	SW revision	Software revision	10 - 255	10: V01.0 ... 255: V25.5	

32	8	DB4.7 – DB4.0	Remaining product lifetime	Countdown time in months until product end of life	0-120	0-120	Month
40	1	DB5.7	Smoke sensor status	Status of the smoke sensor	0: OK 1: Smoke sensor fault		
41	1	DB5.6	Temperature / humidity sensor status	Status of the temperature / humidity sensor	0: OK 1: T°/humidity Sensor fault		
42	1	DB5.5	Reserved	Reserved	Reserved		
43	3	DB5.4 DB5.2	Magnetic base detection	Flag indicating if the product detects a magnetic base	0: Magnetic base not detected 1: Magnetic base detected 2: Product removed from its based just now 3: Product installed on its base just now 4: Magnetic base never detected		
45	2	DB5.1 – DB5.0	Energy status	Battery Level	0: high 1: Medium 2: Low 3: Critical		
47	8	DB6.7 – DB6.0	Battery voltage	Battery voltage, 5 mV step	0 - 250	2000 - 3250	mV

— 02. Configuration of product function

At the start-up product phase, during each reconfiguration and every 7 days, a message is sent to indicate the configuration of the product.

Offset	Size (bit)	Bit-range	Data	Description	Valid Range	Scale	Unit
0	8	DB0.7 DB0.0	Type of product	Product model	ORIGIN+: 0xB1 ORIGIN: 0xB2 GUARD+: 0xB3 GUARD: 0xB4		
8	8	DB1.7 DB1.0	Type of message	Product general Configuration	0x01		
16	3	DB2.7 DB2.5	Reconfiguration source	Source of reconfiguration process	0 : NFC 1 : Applicative Downlink 2 : Product start-up 3-4: Reserved		

					5 : Local 6-8 : Reserved
19	2	DB2.4 DB2.3	Reconfiguration status	Result of reconfiguration process : success or failure ?	0 : Total success 1 : Partial success 2 : Total failure 3 : Reserved
21	1	DB2.2	Temperature datalog enable	Temperature datalog function activated?	0: Non-active; 1: Active
22	1	DB2.1	Daily air quality data enable	Daily air quality data function activated?	0: Non-active; 1: Active
23	1	DB2.0	Reserved	Reserved	Reserved
24	1	DB3.7	Pending join	Join request scheduled	0: No join request scheduled 1: Join request scheduled
25	2	DB3.6 DB3.5	NFC status	Status of NFC interface	0: Discoverable 1: Not discoverable 2..3: RFU
27	4	DB3.4 DB3.1	Reserved	Reserved	Reserved
31	6	DB3.0 DB4.3	Number of new data	Number of new data in datalog message	1 - 36 1 - 36 -
37	5	DB4.2 DB5.6	Number of transmissions	Number of transmission of a same data in datalog function	1 - 24 1 - 24 -
42	8	DB5.5 DB6.6	Transmission period	Transmission period of datalog message	3 - 144 30 - 1440 Minute s
50	17	DB6.5 DB8.5	D2D Network ID	Interconnection network ID	0 - 131071
67	5	DB8.4 DB8.0	Reserved	Reserved	Reserved
72	16	DB9.7 DB10.0	Downlink counter	Downlink counter	0 - 65535

— 03. Smoke alarm status

This message is sent when one of this information changes:

- > Smoke alarm status
- > Smoke test
- > Time since last smoke test
- > Time since last smoke maintenance

Data are sent in the following format:

Offset	Size (bit)	Bit-range	Data	Description	Valid Range	Scale	Unit
0	8	DB0.7 – DB0.0	Type of product	Product model	ORIGIN+: 0xB1 ORIGIN: 0xB2 GUARD+: 0xB3 GUARD: 0xB4		
8	8	DB1.7 – DB1.0	Type of message	Smoke Alarm message	0x02		
16	2	DB2.7 DB2.6	Smoke Alarm status	Status of smoke detection	0: Smoke Alarm non-activated 1: Local smoke Alarm activated 2: Remote smoke Alarm activated 3: Not used		
18	2	DB2.5 DB2.4	Smoke Alarm Hush	Smoke Alarm Hush	0: Smoke alarm stopped because no smoke anymore 1: Smoke alarm stopped following central button press 2: Smoke alarm stopped following a remote silence		
20	2	DB2.3 DB2.2	Smoke Test	Flag indicating if a smoke test has been done	0: Smoke test off 1: Local smoke test was done 2: Remote smoke test was done		
22	8	DB2.1 DB3.2	Time since last smoke test	Time since last smoke test	0-255	0-255	Week
30	1	DB3.1	Maintenance	Flag indicating if a maintenance has been done	0: Maintenance not done 1: Maintenance has been done		
31	8	DB3.0 DB4.1	Time since last maintenance	Time since last maintenance	0-255	0-255	Week
39	10		Temperature		0-1000	- 30..70	°C

		DB4.0 – DB6.7		Temperature (linear), Increment = 0.1°C offset 30°C (e.g: 0=-30°C, 300=0°C, 1000=70°C)	1023: Error
49	7	DB6.6 DB6.0	Not used	Not used	Not used

— 04. Daily air quality

Data are sent in the following format:

Offset	Size (bit)	Bit-range	Data	Description	Valid Range	Scale	Unit
0	8	DB0.7 – DB0.0	Type of product	Product model	ORIGIN+: 0xB1 ORIGIN: 0xB2 GUARD+: 0xB3 GUARD: 0xB4		
8	8	DB1.7 – DB1.0	Type of message	Air quality message	0x03		
16	10	DB2.7 DB3.6	Temperature min.	Temperature (linear), Increment = 0.1°C offset 30°C (e.g: 0=-30°C, 300=0°C, 1000=70°C)	0-1000	-30..70	°C
					1023: Error		
26	10	DB3.5 DB4.4	Temperature max.	Temperature (linear), Increment = 0.1°C offset 30°C (e.g: 0=-30°C, 300=0°C, 1000=70°C)	0-1000	-30..70	°C
					1023: Error		
36	10	DB4.3 DB5.2	Temperature average.	Temperature (linear), Increment = 0.1°C offset 30°C (e.g: 0=-30°C, 300=0°C, 1000=70°C)	0-1000	-30..70	°C
					1023: Error		
46	8	DB5.1 DB6.2	Relative Humidity min.	Relative Humidity (linear), 0.5%RH step	0-200	0-100	% RH
					255: Error		

54	8	DB6.1 DB7.2	Relative Humidity max.	Relative Humidity (linear), 0.5%RH step	0-200	0-100	% RH
					255: Error		
62	8	DB7.1 DB8.2	Relative Humidity average	Relative Humidity (linear), 0.5%RH step	0-200	0-100	% RH
					255: Error		
70	2	DB8.1 DB8.0	Not used	Not used	Not used		

— 05. Periodic Data

Data are sent in the following format:

Offset	Size (bit)	Bit-range	Data	Description	Valid Range	Scale	Unit
0	8	DB0.7 DB0.0	Product Type	Product model	ORIGIN+: 0xB1 ORIGIN: 0xB2 GUARD+: 0xB3 GUARD: 0xB4		
8	8	DB1.7 DB1.0	Type of message	Periodic data	0x04		
16	10	DB2.7 DB3.6	Temperature	Temperature (linear), Increment = 0.1°C offset 30°C (e.g: 0=-30°C, 300=0°C, 1000=70°C)	0-1000	- 30..70	°C
26	8	DB3.5 DB4.6	Relative Humidity	Relative humidity (linear), increment = 0.5%RH	0-200	0-100	% RH
					255: Error		
34	6	DB4.5 DB4.0	Not used	Not used	Not used		

— 06. Temperature datalog

Data are logged and sent at regular intervals. They are ordered from the most recent value to the oldest. The first value (index n in the message description) is the current value. The n-1 value represents the previously measured value and so on. Time between two measures is indicated in each message to simplify the decoding operations.

Data are sent in the following format:

Offset	Size (bit)	Bit-range	Data	Description	Valid Range	Scale	Unit
0	8	DB0.7 DB0.0	Type of product	Product model	ORIGIN+: 0xB1 ORIGIN: 0xB2 GUARD+: 0xB3 GUARD: 0xB4		
8	8	DB1.7- DB1.0	Type of message	Temperature datalog	0x05		
16	6	DB2.7 DB2.2	Number of measurements	Total number of data contained in this frame	1 - 36	1 - 36	N/A
22	8	DB2.1 DB3.2	Period between the measurements	Time in minutes between each measurements	10-200	10-200	min
30	6	DB3.1 DB4.4	Repetition	Number of repetition of a same measurement	1 - 24	1 - 24	N/A
36	10	DB4.3 DB5.2	Temperature [n]	Temperature (linear), Increment = 0.1°C offset 30°C (e.g: 0=-30°C, 300=0°C, 1000=70°C)	0-1000	-30..70	°C
46	10	DB5.1 DB6.0	Temperature [n-1]	Temperature (linear), Increment = 0.1°C offset 30°C (e.g: 0=-30°C, 300=0°C, 1000=70°C)	0-1000	-30..70	°C
...
...	10	DB.. DB..	Temperature [n-x]	Temperature (linear), Increment = 0.1°C offset 30°C (e.g: 0=-30°C, 300=0°C, 1000=70°C)	0-1000	-30..70	°C
...	...	DB.. DB..	Not used	Not used	Not used		

XII. Product configuration and remote commands

An online downlink calculation tool is available : <https://nexelec-support.fr/n/downlink>

The product can be reconfigured to best fit each use case. This reconfiguration can be done :

- Locally, using a smartphone or a tablet via the NFC TOUCH application
- Remotely, via the LoRaWAN connection interface

1. Configurations for temperature/humidity transmission

Configuration type	Default value	Possible configuration
Daily air quality	On	On Off
Temperature datalog	On	On Off
Number of new data in a datalog message	6	1 – 36
Datalog transmission period	3	3 – 24h
Number of transmission of a same measure	3	1 - 24

2. Configurations for product maintenance, reliability and security

Configuration type	Possible configuration
NFC interface accessibility	Discoverable Not discoverable
Product restart	-
Restore to factory configuration	-
LoRaWAN Join request	Delay before connection attempt : 10 – 10080 minutes*

*: Via NFC TOUCH smartphone application, this parameter is not reconfigurable and the join request is immediate.

3. Configurations related to interconnection

Configuration type	Default value	Possible configuration
Interconnection network ID	0	1 - 131071
Remove product from interconnected network	-	-

XIII. Product reconfiguration via downlink message

Product can be reconfigured via downlink message in response to any uplink message. The downlink message must be sent on port 56.

1. Reconfiguration acknowledgment

After reconfiguration, the product will send a message twice with its updated configuration (Refer to section XI.4.2. Configuration of product function).

2. Downlink message structure

First byte is the header: 0x55.

Then the following bytes can be used to reconfigure the product with respect to the format: Command ID and DATA.

Note: Downlink functionalities will certainly progress in the future. To ensure backwards-compatibility, Nexelec recommends sending the IDs from the lowest to the highest value.

ID	Data length (byte)	Range	Scale	Description
0x01	0	-	-	Ask for general configuration of the product (message Configuration of product functions)
0x0A	1	0 / 1	0 : disabled 1 : enabled	NFC interface enable
0x1C	2	1 - 1008	10 – 10080 minutes	Schedule a join request in x minutes
0x28	1	0/1	0 : disabled 1 : enabled	Temperature datalog enable

0x2A	1	0/1	0 : disabled 1 : enabled	Daily air quality enable
0x4A	1	1	-	Product restart
0x4B	1	1	-	Product restart and restore to factory configuration
0x4F	3	1 - 131071	D2D Network ID: 1 - 131071	Join the D2D network of ID x
0x50	1	1	1 : D2D unpairing request	Delete the product from the D2D network
0x5D	1	1 - 36	1 - 36	Number of new data included in a datalog message
0x5E	1	18 - 144	180 – 1440 minutes (24h)	Datalog transmission period
0x5F	1	1 - 24	1 - 24	Number of transmission of a same data

Example 1:

- > Deactivate daily air quality function
- > Configure datalog transmission period to 6h

Frame structure from LSB to MSB:

Byte	Value	Info
0	0x55	Header for 1- message reconfiguration
1	0x2A	ID Daily Air quality enable
2	0x00	Value to disable daily air quality
3	0x5E	ID Datalog transmission period
4	0x24	Value to configure temperature datalog transmission period to 6h

Example 2:

- > Add the product to the D2D network of ID 6921 (0x001B09)

Frame structure from LSB to MSB:

Byte	Value	Info
0	0x55	Header for 1- message reconfiguration
1	0x4F	ID Join an interconnected network
2	0x00	Value for D2D Network ID 6921
3	0x1B	Value for D2D Network ID 6921
4	0x09	Value for D2D Network ID 6921

XIV. NFC configuration

The product has a NFC interface that allows communication with a smartphone equipped with the TOUCH application. This interface allows to:

- > Configure the product according to your use case
- > Access the latest temperature and humidity data
- > Update the product software

The NFC interface can be remotely activated or deactivated via a LoRaWAN downlink message. By this way, the NFC memory is no more discoverable by a phone, preventing reconfiguration of the product once deployed.

1. NFC antenna location

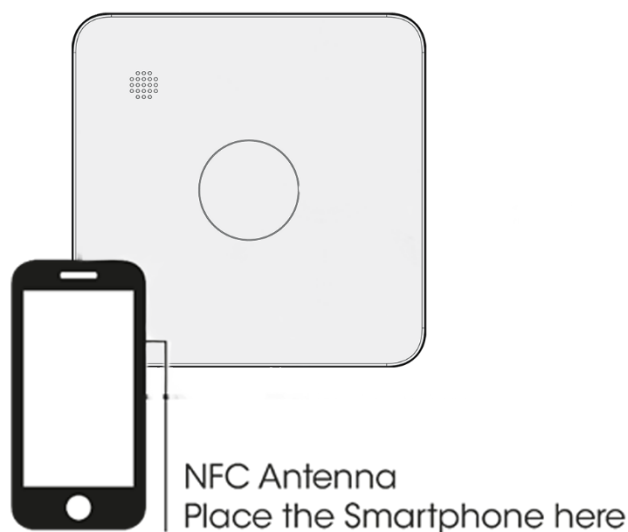

2. Application download

The *TOUCH* product reconfiguration application is available on Android and iOS for devices (mobile, tablet) equipped with NFC interface.

3. Access to TOUCH Android application documentation

Documentation for the TOUCH application is available on the support site :

<https://support.nexelec.fr/fr/support/solutions/folders/80000680573>

XV. Traceability and markings

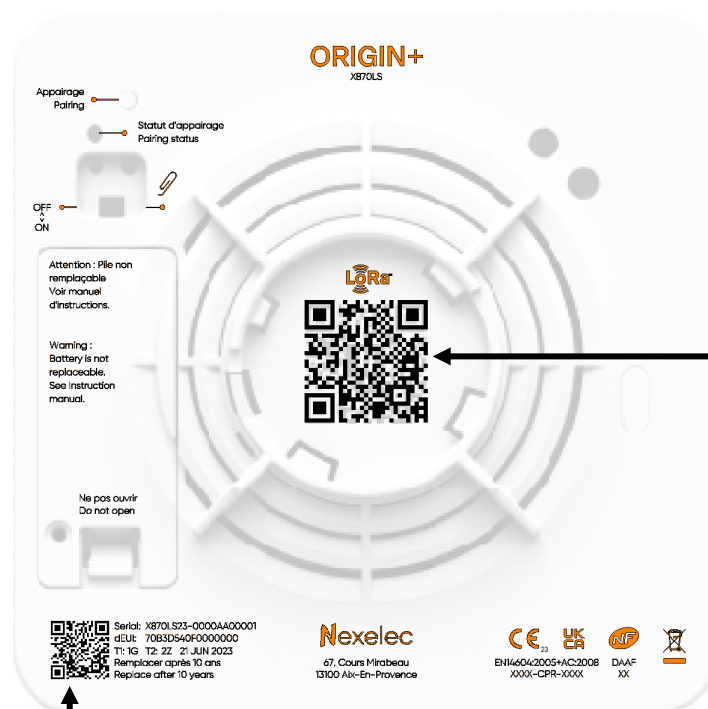

QR Code format : **Serial_number**;**Testbench**;**Date**;**LoRadevEUI**

Example : **X870LS23-0532PV0014**;**1M-2F**;**090823**;**70B3D540F557D40E**

QR Code format : **LW**:**Device_schema_version**:**LoRa_AppEUI**:**LoRa_DevEUI** :**Owner_Token**:**Serial_number**

Example : **LW**:**D0**:**70B3D540FA4A80ED**:**70B3D540F557D40E**:**FFFF0870**:**SX870LS23-0532PV0014**

XVI. Revision history

Document revision	Details	Date
A	Created	10/10/2023
B	Delete the possibility to reconfigure the time zone (not required for normal product operation) Applicable from software version V01.1	05/12/2023