



LG308 LoRaWAN Gateway User Manual

Document Version: 1.3.0

Firmware Version: LG02_LG08--build-v5.4.1590459021-20200526-1012

Version	Description	Date
1.0	Release	2018-Nov-17
1.1	Add notice for recover mode. Add hardware source code Add FAQ for customized frequency.	2019-Jan-10
1.1.1	Add how to control LED. Add	
1.1.2	Remove SX1276 description and GPS.	
1.1.3	Change the HTTP Port and SSH port for firmware version > v5.3	2019-Nov-26
1.2.0	Add more features such packet filter, remote access	2020-Mar-02
1.2.1	Add contents for access to the device	2020-Mar-16
1.3.0	Update manual to the new version of UI	

1. Introduction	5
1.1 What is LG308	5
1.2 Specifications	6
1.3 Features	7
1.4 Hardware System Structure	7
1.5 LG308 Applications	8
1.6 LED Indicators	8
2. Access and configure LG308	9
2.1 Find IP address of DLOS8	9
2.1.1 Connect via WiFi	9
2.1.2 Connect via WAN port with DHCP IP from router	9
2.1.3 Connect via LAN port with direct connection from PC	10
2.1.4 Connect via WiFi with DHCP IP from router	10
2.1.5 Connect via LAN port by fall back ip	10
2.2 Access Configure Web UI	11
3. Typical Network Setup	12
3.1 Overview	12
3.2 Use WAN port to access Internet	12
3.3 Access Internet as a WiFi Client	13
3.4 Use built-in 4G modem for internet access	14
3.5 Check Internet connection	15
4. Example : Configure as a LoRaWAN gateway	16
4.1 Create a gateway in TTN Server	16
4.2 Configure LG308 to connect to TTN	18
4.3 Configure frequency	20
4.4 Add a LoRaWAN End Device	21
5. Web Configure Pages	23
5.1 Home	23
5.2 LoRa Settings	24
5.2.1 LoRa --> LoRa	24
5.2.2 LoRa --> ABP Decryption	25

5.3	LoRaWAN Settings.....	26
5.3.1	LoRaWAN --> LoRaWAN.....	26
5.3.2	LoRaWAN --> LORIoT.....	26
5.4	MQTT Settings.....	27
5.5	System.....	28
5.5.1	System --> System Overview.....	28
5.5.2	System --> General (login settings).....	28
5.5.3	System --> Network.....	30
5.5.4	System --> WiFi.....	31
5.5.5	System --> Cellular.....	31
5.5.6	System --> Network Status.....	32
5.5.7	System --> Remote Mgmt.....	32
5.5.8	System --> Firmware Upgrade.....	33
5.5.9	System --> Reboot/Reset.....	34
5.5.10	System --> Package Maintain.....	35
5.6	LogRead.....	36
5.6.1	LogRead --> LoRa Log.....	36
5.6.2	LogRead --> System Log.....	36
6.	More features.....	37
6.1	More instructions.....	37
7.	Linux System.....	38
7.1	SSH Access for Linux console.....	38
7.2	Edit and Transfer files.....	39
7.3	File System.....	39
7.4	Package maintain system.....	40
8.	Upgrade Linux Firmware.....	41
9.	FAQ.....	42
9.1	How can I configure for a customized frequency band?.....	42
9.2	Can I connect DLOS8 to LORIoT?.....	42
9.3	Can I make my own firmware for the gateway, where can I find the source code?.....	42
9.4	Can I use 868Mhz version for 915Mhz bands?.....	42
9.5	Can I control the LEDs?.....	42
10.	Trouble Shooting.....	43
10.1	I get kernel error when install new package, how to fix?.....	43

10.2	<i>How to recover the LG308 if firmware crash</i>	<i>44</i>
10.3	<i>I configured LG308 for WiFi access and lost its IP. What to do now?.....</i>	<i>44</i>
11.	Order Info	45
12.	Packing Info	45
13.	Support.....	45
14.	Reference.....	47

1. Introduction

1.1 What is LG308

The LG308 is an open source **LoRaWAN Pico Gateway**. It lets you bridge LoRa wireless network to an IP network via WiFi, Ethernet, 3G or 4G cellular network. The LoRa wireless allows users to send data and reach extremely long ranges at low data-rates.

The LG308 uses **Semtech packet forwarder** and fully compatible with LoRaWAN protocol. It includes a **SX1301 LoRa concentrator**, which provides 10 programmable parallel demodulation paths.

LG308 has **pre-configured standard LoRaWAN frequency bands** to use for different countries.

User can also **customize the frequency bands** to use in their own LoRa network.

LG308 can communicate with ABP LoRaWAN end node without LoRaWAN server. System integrator can use it to integrate with their existing IoT Service without set up own LoRaWAN server or use 3rd party LoRaWAN service.

LG308 In a LoRaWAN IoT Network:

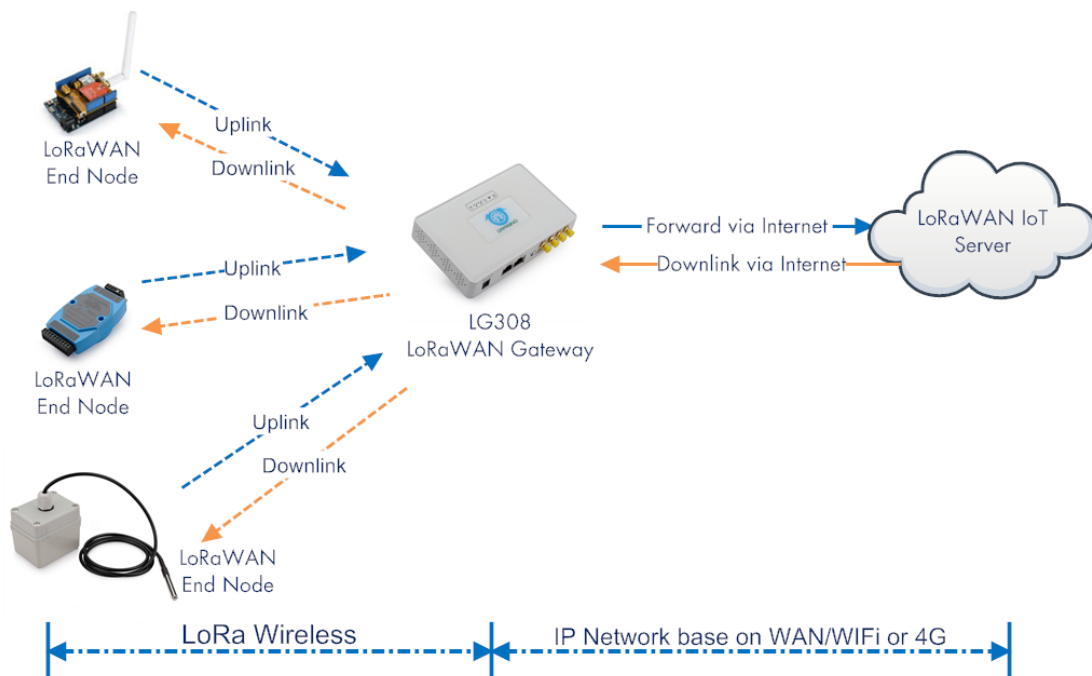

1.2 Specifications

Hardware System:

Linux Part:

- 400Mhz ar9331 processor
- 64MB RAM
- 16MB Flash

Interface:

- 10M/100M RJ45 Ports x 2
- WiFi : 802.11 b/g/n
- LoRaWAN Wireless
- Power Input: 12V DC, 1 A
- USB 2.0 host connector x 1
- Mini-PCI E connector x 1
- SX1301 + 2 x SX1257

WiFi Spec:

- IEEE 802.11 b/g/n
- Frequency Band: 2.4 ~ 2.462GHz
- Tx power:
 - ✓ 11n tx power : mcs7/15: 11db mcs0 : 17db
 - ✓ 11b tx power: 18db
 - ✓ 11g 54M tx power: 12db
 - ✓ 11g 6M tx power: 18db
- Wifi Sensitivity
 - ✓ 11g 54M : -71dbm
 - ✓ 11n 20M : -67dbm

LoRa Spec:

- Up to -142.5dBm sensitivity with SX1257 Tx/Rx front-end
- 70 dB CW interferer rejection at 1 MHz offset
- Able to operate with negative SNR, CCR up to 9dB
- Emulates 49x LoRa demodulators and 1x (G)FSK demodulator
- Dual digital TX&RX radio front-end interfaces
- 10 programmable parallel demodulation paths
- Dynamic data-rate (DDR) adaptation
- True antenna diversity or simultaneous dual-band operation

Cellular 4G LTE (optional):

- Quectel [EC25 LTE module](#)
- Micro SIM Slot
- External 4G Sticker Antenna.

- Up to 150Mbps downlink and 50Mbps uplink data rates
- Worldwide LTE,UMTS/HSPA+ and GSM/GPRS/EDGE coverage
- MIMO technology meets demands for data rate and link reliability in modem wireless communication systems

1.3 Features

- ✓ Open Source Linux system
- ✓ Managed by Web GUI, SSH via LAN or WiFi
- ✓ Emulates 49x LoRa demodulators
- ✓ LoRaWAN Gateway
- ✓ 10 programmable parallel demodulation paths

1.4 Hardware System Structure

LG308 System Overview:

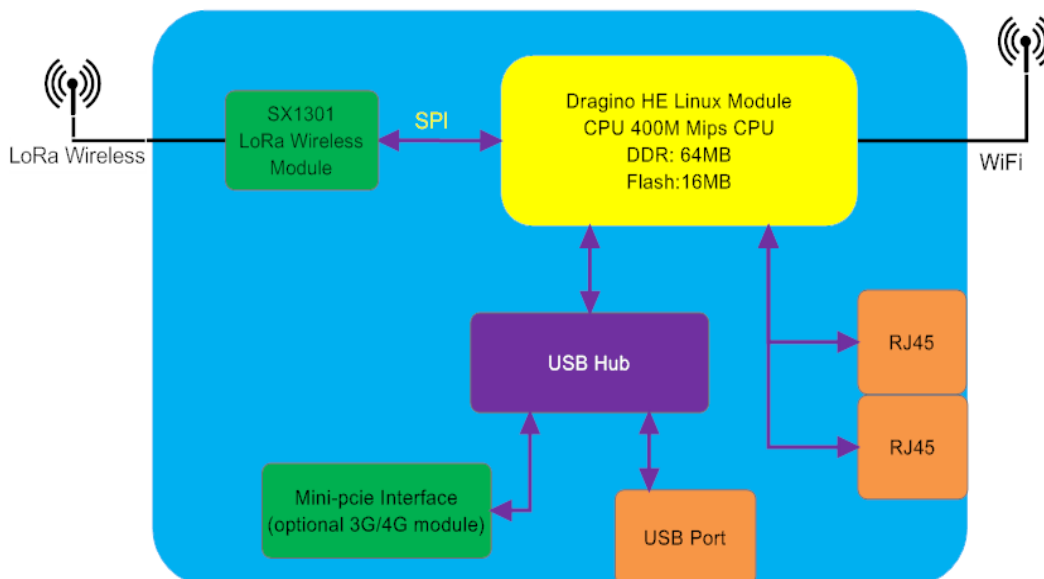







1.5 LG308 Applications



1.6 LED Indicators

LG308 has totally 6 LEDs, They are:

- **Power LED** : This **LED** will be **solid on** if the device is properly powered.
- **HEART LED** : No function yet.
- **SYS LED** : This **LED** will shows different colors on different state:
 - ✓ **SOLID:** Device is alive with LoRaWAN server connection.
 - ✓ **BLINKING:** a) Device has internet connection but no LoRaWAN Connection. or b) Device is in booting stage, in this stage, it will **BLINKING** for several seconds.
 - ✓ **OFF:** Device doesn't have Internet connection.
- **ETH LED**  : These two LEDs show the ETH interfaces connection status.
- **WiFi LED** : This LED shows the WiFi interface connection status.

Note: Above LED indication are for firmware version > LG02_LG08--build-v5.3.1584002217-20200312-1639

2. Access and configure LG308

The LG308 is configured as a WiFi Access Point by default. User can access and configure the LG308 after connecting to its WiFi network, or via its Ethernet port.

2.1 Find IP address of DLOS8

2.1.1 Connect via WiFi



At the first boot of LG308, it will auto generate an unsecure WiFi network call **dragino-xxxxxx**

Note: In latest version firmware, it has been password protected and the password is:
dragino+dragino

User can use the laptop to connect to this WiFi network. The laptop will get an IP address 10.130.1.xxx and the LG308 has the default IP **10.130.1.1**



2.1.2 Connect via WAN port with DHCP IP from router

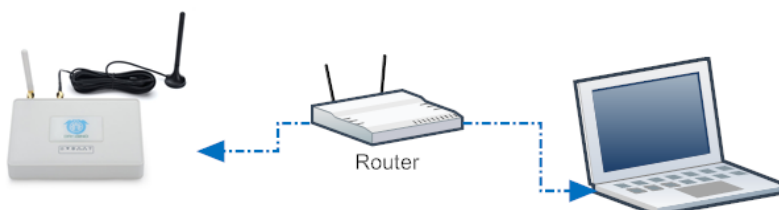

Alternatively, connect the LG308 **WAN port** to your router and LG308 will obtain an IP address from your router. In the router's management portal, you should be able to find what IP address the router has assigned to the LG308. You can also use this IP to connect.

2.1.3 Connect via LAN port with direct connection from PC



The LG308 **LAN port** is configured as DHCP router by default, user can connect the PC to LAN port and set PC to DHCP mode, it will get IP from LAN port and be able to access to the device. The default IP in LAN port is 10.130.1.1

2.1.4 Connect via WiFi with DHCP IP from router

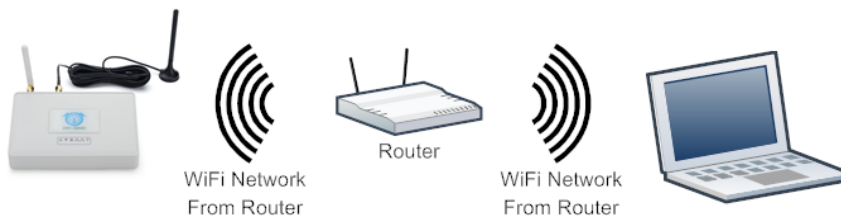

If the LG308 already connect to the router via WiFi, use can use the WiFi IP to connect to LG308.

2.1.5 Connect via LAN port by fall back ip

The **LAN port** also has a [fall back ip address](#) for access if user doesn't connect to uplink router.

2.2 Access Configure Web UI

Web Interface

Open a browser on the PC and type the LG308 ip address (depends on your connect method)

<http://10.130.1.1/> (Access via WiFi AP network)

or

http://IP_ADDRESS or http://IP_ADDRESS:8000 (If the IP is assigned by uplink router)

You will see the login interface of LG308 as shown below.

The account details for Web Login are:

User Name: root

Password: dragino

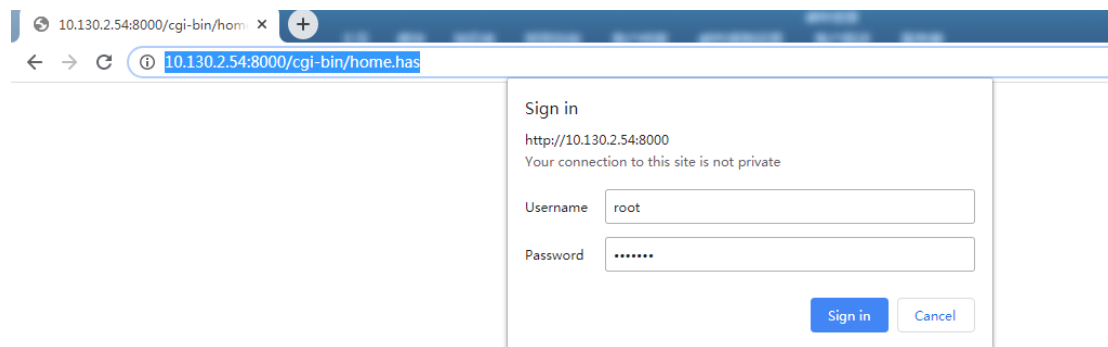

3. Typical Network Setup

3.1 Overview

LG308 supports flexible network set up for different environment. This section describes the typical network topology can be set in LG308. The typical network set up includes:

- ✓ WAN Port Internet Mode
- ✓ WiFi Client Mode
- ✓ WiFi AP Mode
- ✓ USB Dial Up Mode

3.2 Use WAN port to access Internet

By default, LG308 is set to use the WAN port to connect to an upstream network. When you connect the LG308's WAN port to an upstream router, LG308 will get an IP address from the router and have Internet access via the upstream router. The network status can be checked in the [home page](#):

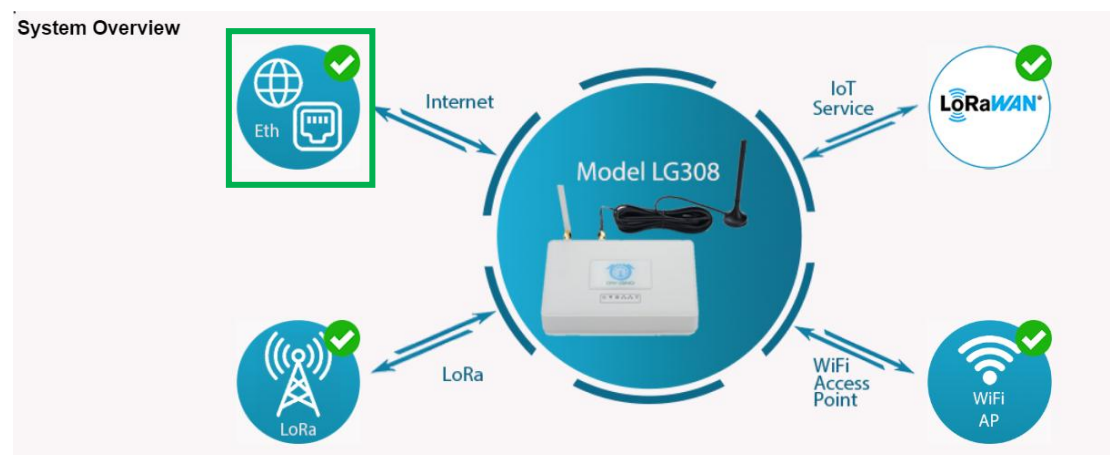

3.3 Access Internet as a WiFi Client.

In the WiFi Client Mode, LG308 acts as a WiFi client and gets DHCP from an upstream router via WiFi.

The settings for WiFi Client is under page [System](#) → [WiFi](#) → [WiFi WAN Client Settings](#)

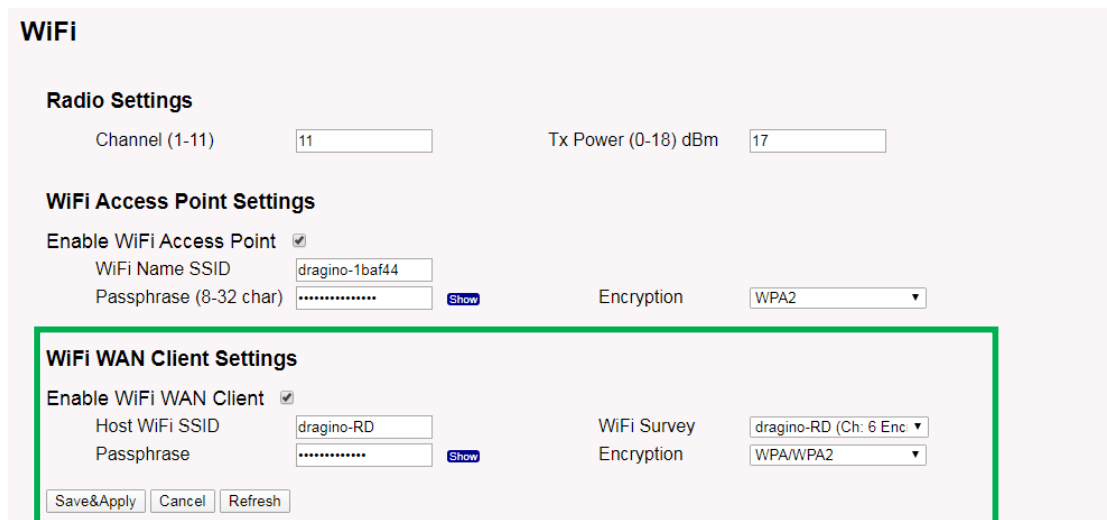

WiFi

Radio Settings

Channel (1-11) Tx Power (0-18) dBm

WiFi Access Point Settings

Enable WiFi Access Point

WiFi Name SSID

Passphrase (8-32 char) [Show](#) Encryption

WiFi WAN Client Settings

Enable WiFi WAN Client

Host WiFi SSID

Passphrase [Show](#) WiFi Survey

Encryption

In the WiFi Survey Choose the WiFi AP, and input the Passphrase then click Save & Apply to connect.

3.4 Use built-in 4G modem for internet access

If the LG308 has 3G/4G Cellular modem, user can use it as main internet connection or back up.

First, install the Micro SIM card as below direction

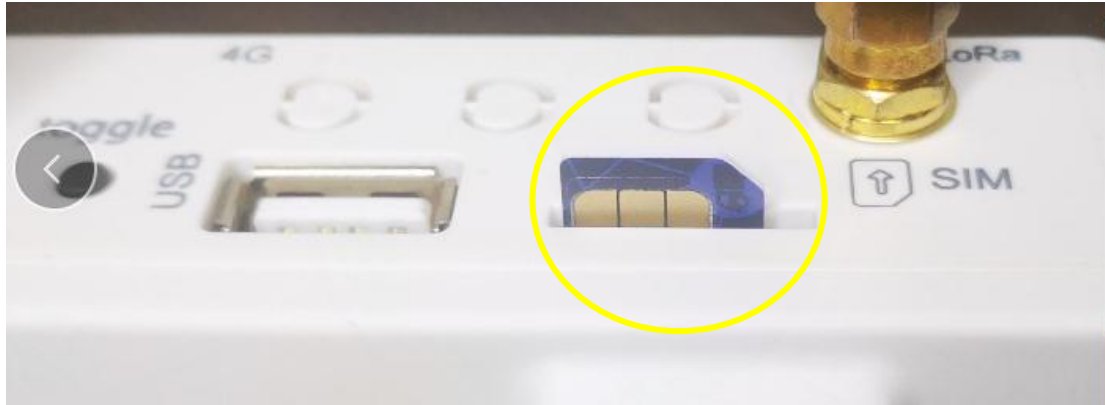

The set up page is [System](#) → [Cellular](#)

While use the cellular as Backup WAN, device will use Cellular for internet connection while WAN port or WiFi is not valid and switch back to WAN port or WiFi after they recover.



Cellular Settings

- Enable Cellular WAN
- Use Cellular as Backup WAN

APN	<input type="text" value="3gnet"/>
Service	<input type="text" value="UMTS / GPRS"/>
Dial Number	<input type="text" value="*99#"/>
Pincode	<input type="text" value="SIM Pincode"/>
Username	<input type="text" value="SIM Acct Username"/>
Password	<input type="text" value="SIM Acct Password"/> Show

3.5 Check Internet connection

In the [Home](#) page, we can check the Internet connection.

- GREEN Tick  : This interface has Internet connection.
- Yellow Tick  : This interface has IP address but don't use it for internet connection.
- RED Cross  : This interface doesn't connected.

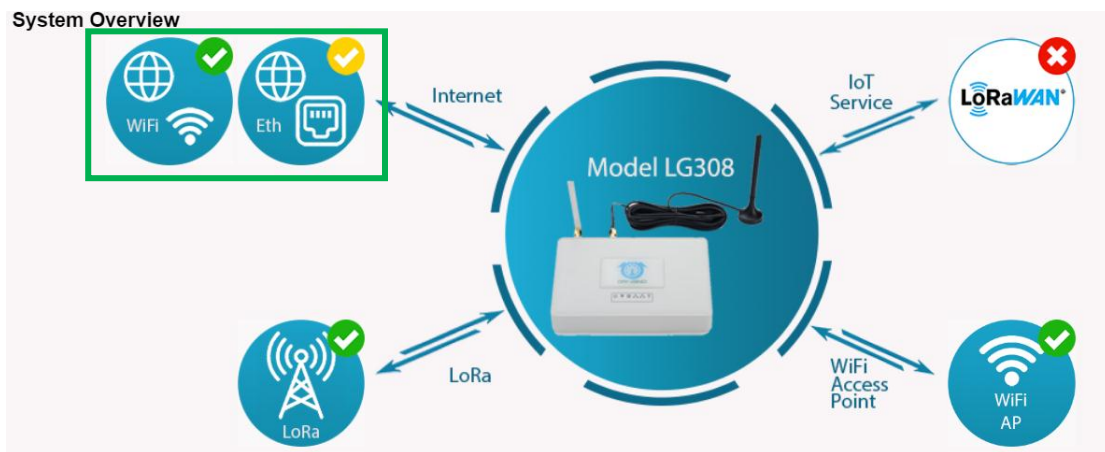

4. Example : Configure as a LoRaWAN gateway

LG308 is fully compatible with LoRaWAN protocol. It use the legacy Semtech Packet forwarder to forward the LoRaWAN packets to server, the structure is as below.

LG308 In a LoRaWAN IoT Network:

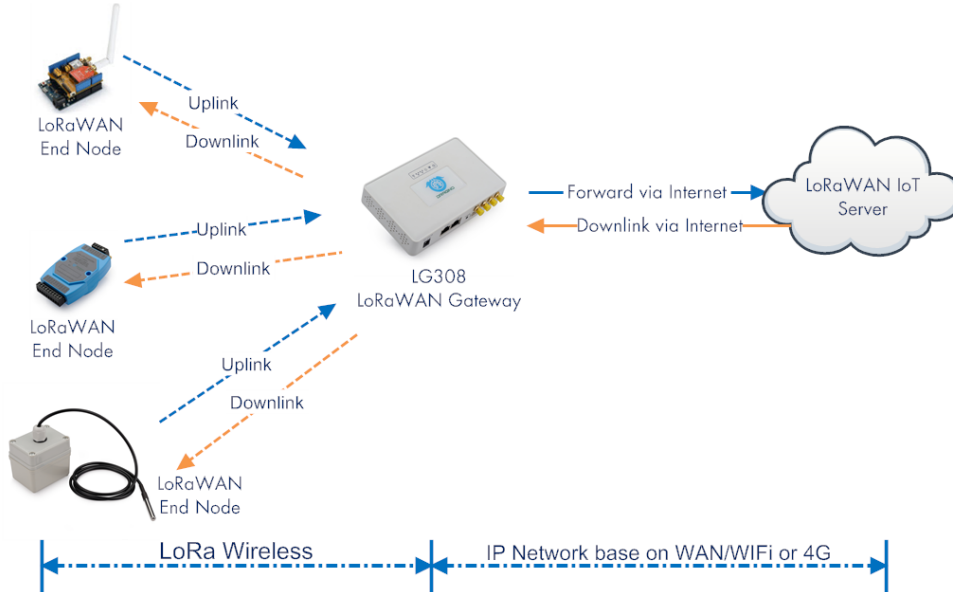

This chapter describes how to use LG308 to work with [TTN LoRaWAN Server](#). The method to work with other LoRaWAN server is similar.

4.1 Create a gateway in TTN Server

Step 1: Get a Unique gateway ID.

Every LG308 has a unique gateway id. The id can be found at LoRaWAN page:

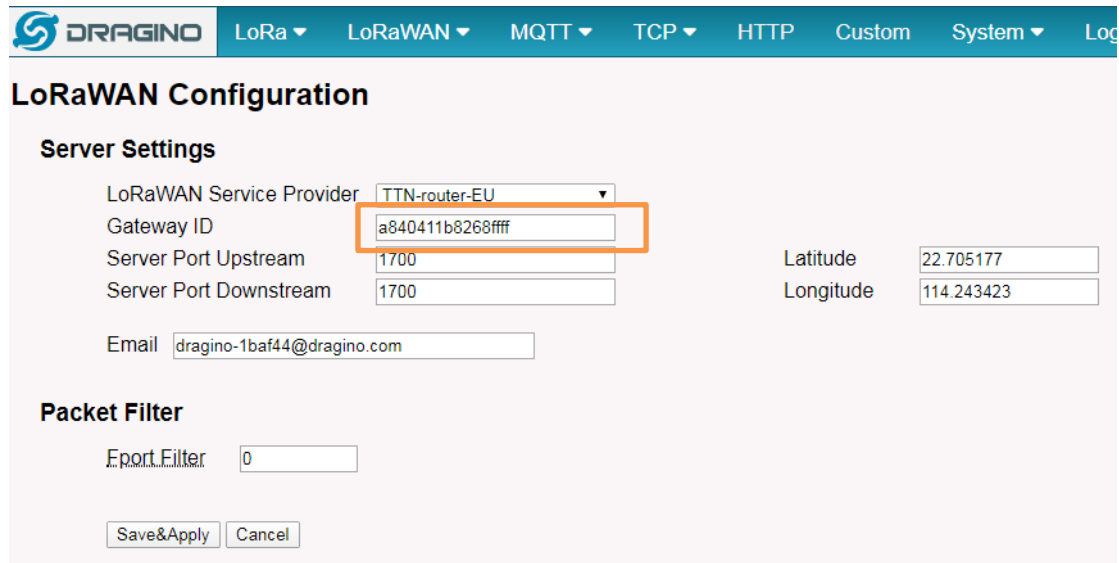

The gateway id is: **a840411b8268ffff**

Step 2: Sign up a user account in TTN server

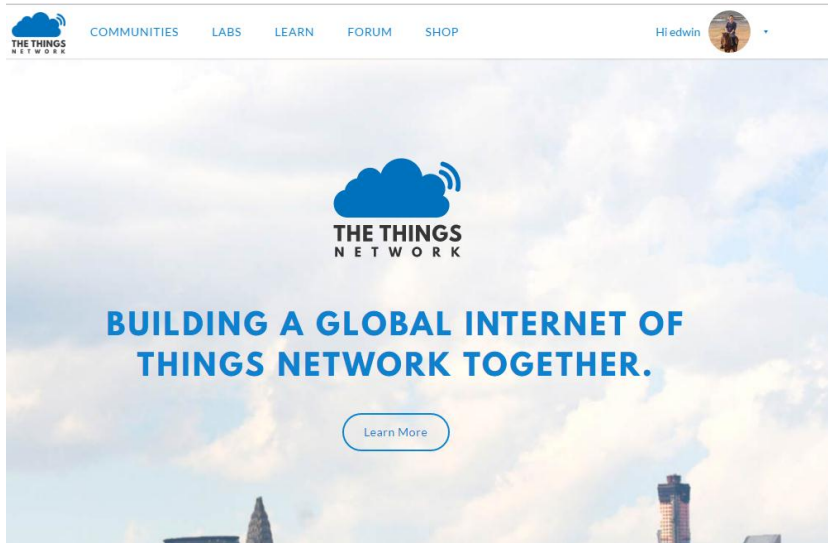

Step 3: Create a Gateway

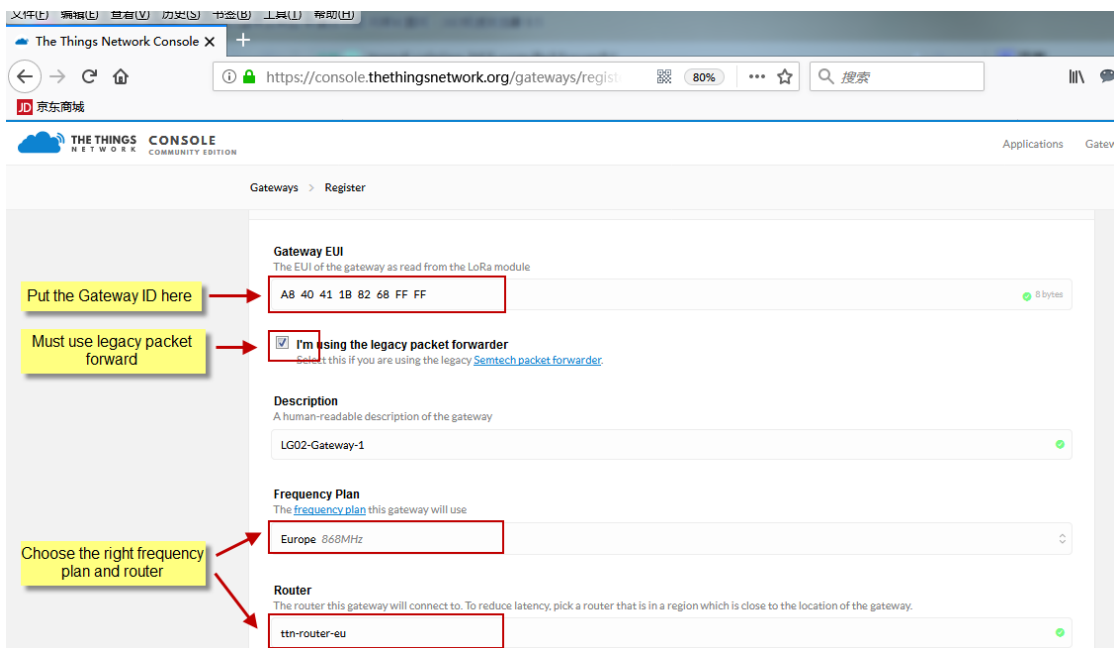
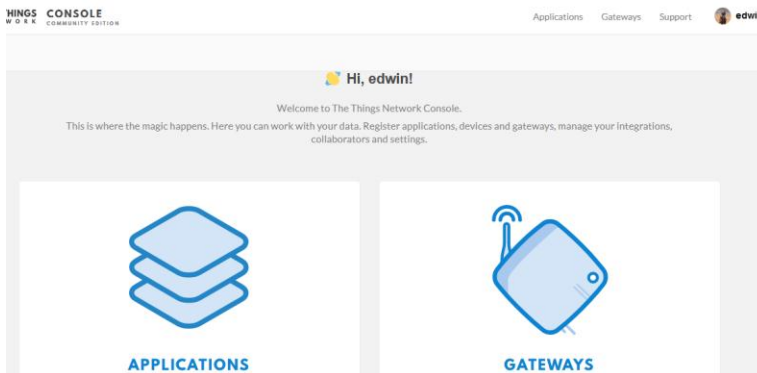

Notice: The TTN router should match the Frequency Plan you choose, otherwise you will have problem for End Node to join the network. If you don't which router you need to select, please check:

https://www.thethingsnetwork.org/docs/gateways/packet-forwarder/semtech-udp.html#connect-a-gateway_server-addresses

After create the gateway, we can see the gateway info, as below

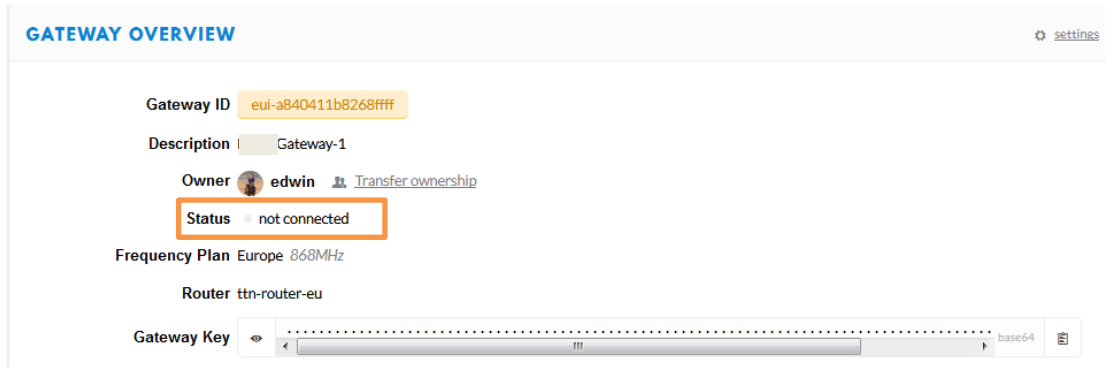

4.2 Configure LG308 to connect to TTN

We should configure the LG308 now to let it connect to TTN network. Make sure your LG308 has Internet Connection first.

Choose the right server provider and click **Save&Apply**

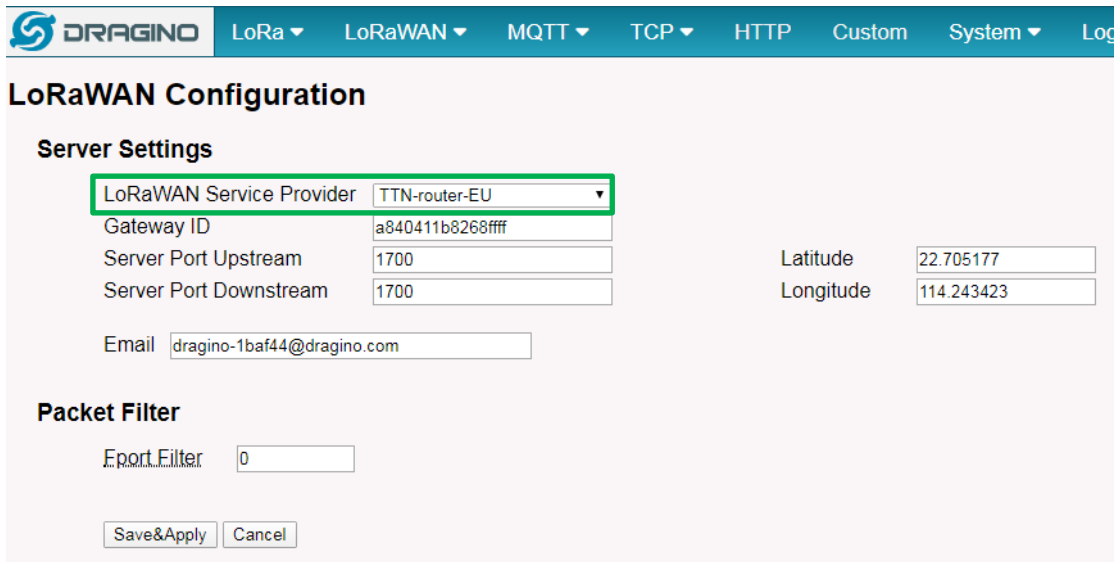

Note: The server address must match the router you choose in TTN.

In the home page, we can see the LoRaWAN connection is ready now.

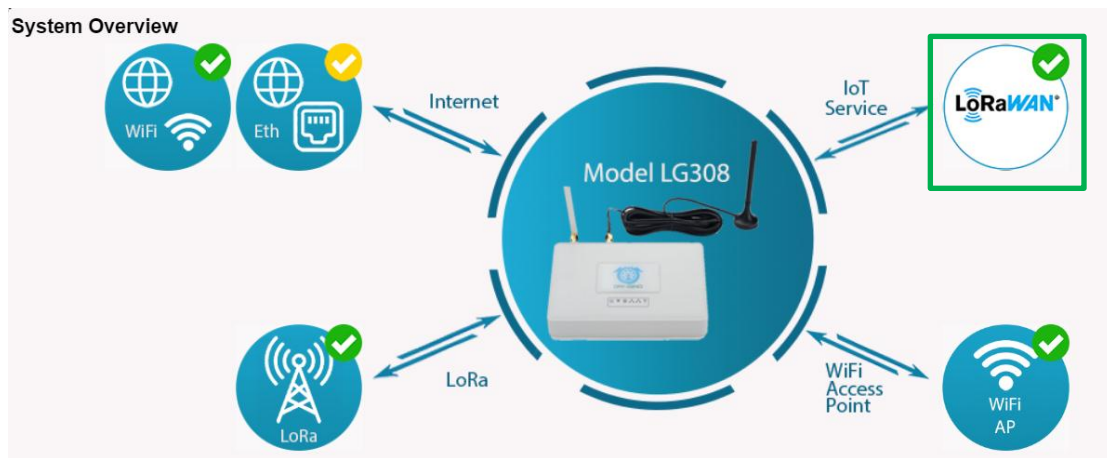

Check Result

After above settings, the LG308 should be able to connect to TTN, below is the result seen from TTN:

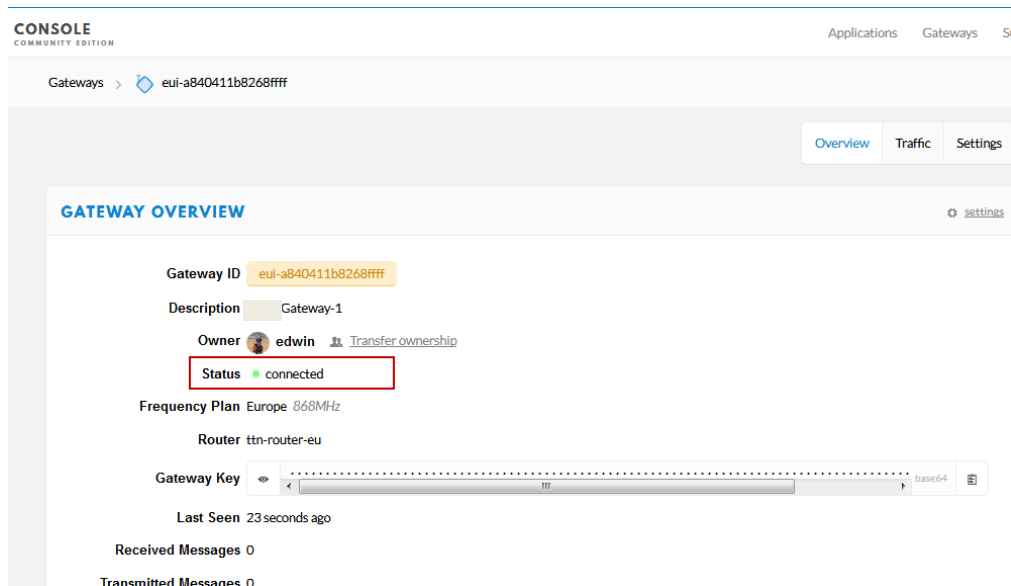

4.3 Configure frequency

We also need to set the frequency plan in LG308 to match the LoRaWAN end node we use, so to receive the LoRaWAN packets from the LoRaWAN sensor.

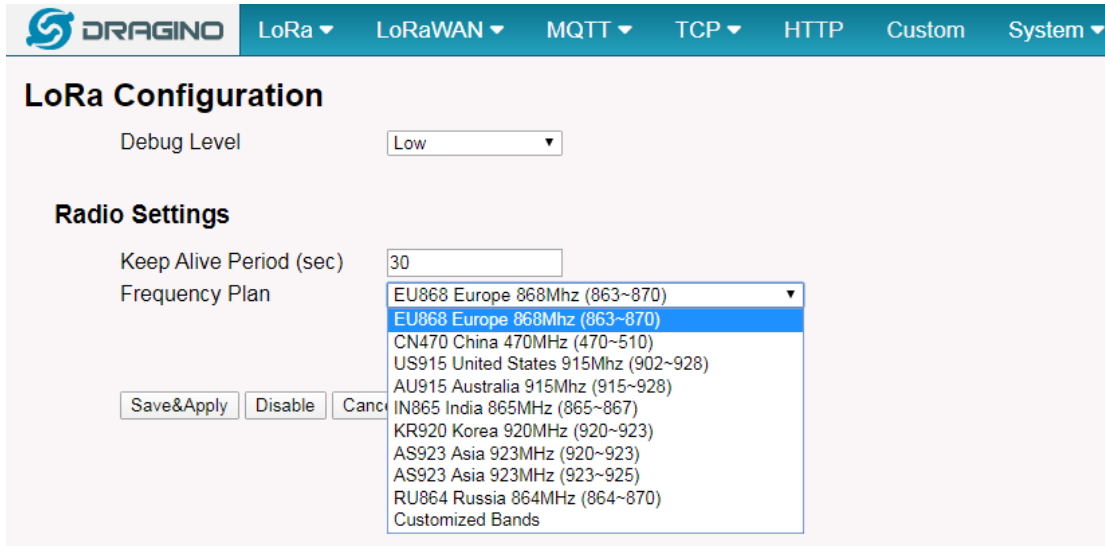

LoRa Configuration

Debug Level:

Radio Settings

Keep Alive Period (sec):

Frequency Plan:

Save&Apply | Disable | Cancel

- EU868 Europe 868Mhz (863~870)
- EU868 Europe 868Mhz (863~870)
- CN470 China 470MHz (470~510)
- US915 United States 915Mhz (902~928)
- AU915 Australia 915Mhz (915~928)
- IN865 India 865MHz (865~867)
- KR920 Korea 920MHz (920~923)
- AS923 Asia 923MHz (920~923)
- AS923 Asia 923MHz (923~925)
- RU864 Russia 864MHz (864~870)
- Customized Bands

In logread page, user can check the frequency actually used.

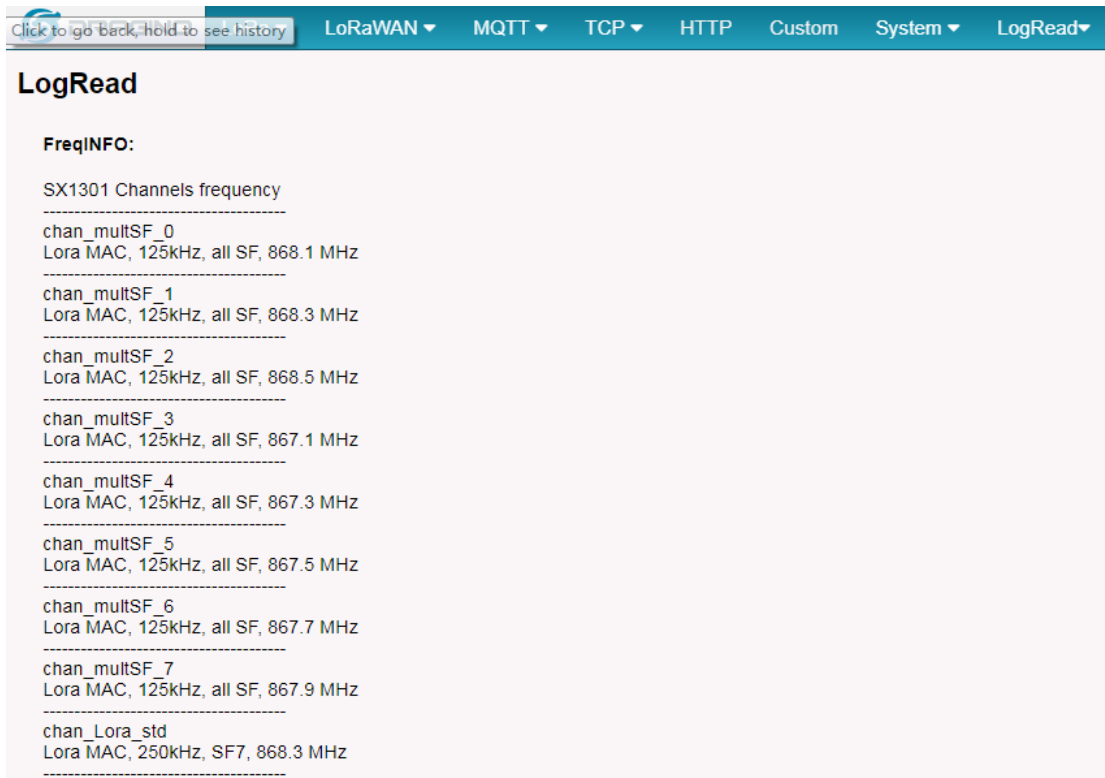

LogRead

Click to go back, hold to see history

FreqINFO:

SX1301 Channels frequency

chan_multSF_0
Lora MAC, 125kHz, all SF, 868.1 MHz

chan_multSF_1
Lora MAC, 125kHz, all SF, 868.3 MHz

chan_multSF_2
Lora MAC, 125kHz, all SF, 868.5 MHz

chan_multSF_3
Lora MAC, 125kHz, all SF, 867.1 MHz

chan_multSF_4
Lora MAC, 125kHz, all SF, 867.3 MHz

chan_multSF_5
Lora MAC, 125kHz, all SF, 867.5 MHz

chan_multSF_6
Lora MAC, 125kHz, all SF, 867.7 MHz

chan_multSF_7
Lora MAC, 125kHz, all SF, 867.9 MHz

chan_Lora_std
Lora MAC, 250kHz, SF7, 868.3 MHz

After doing above LG308 will be able to act as LoRaWAN Gateway. Below section shows how to add a LoRaWAN End device in this LoRaWAN network and see the data from TTN.

We use LT-22222-L as a reference below, for other LoRaWAN devices will be more or less the same.

4.4 Add a LoRaWAN End Device



Step 1: Create a device in TTN with the OTAA keys from LT IO controller. Each LT is shipped with a sticker with the default device EUI as below:



User can enter this key in their LoRaWAN Server portal. Below is TTN screen shot:
Add APP EUI in the application.

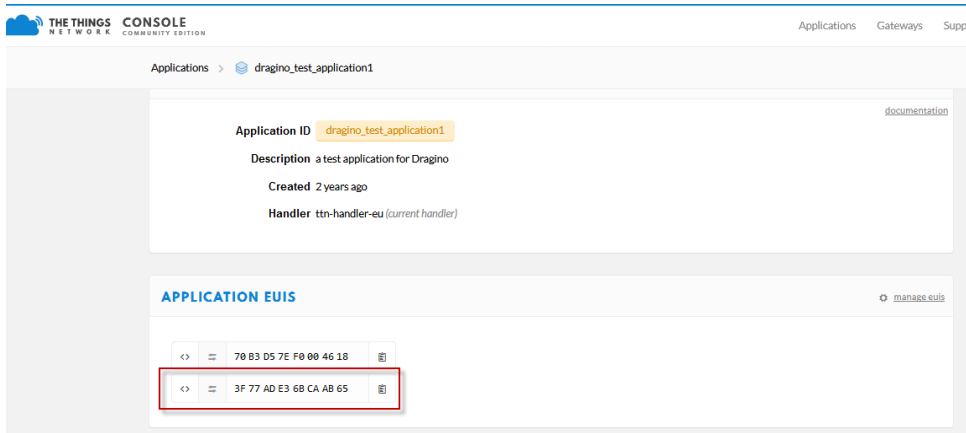

Add APP KEY and DEV EUI

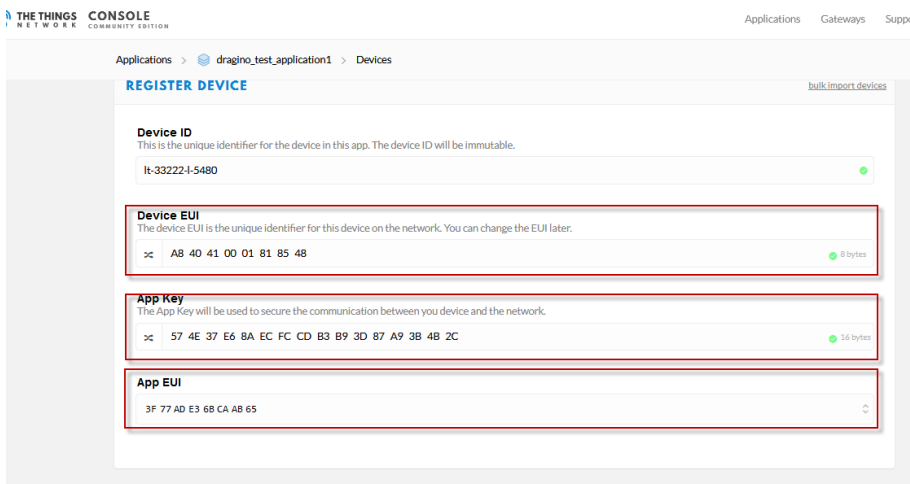

Step 2: Power on LT and it will auto join to the TTN network. After join success, it will start to upload message to TTN and user can see in the panel and analyze the data

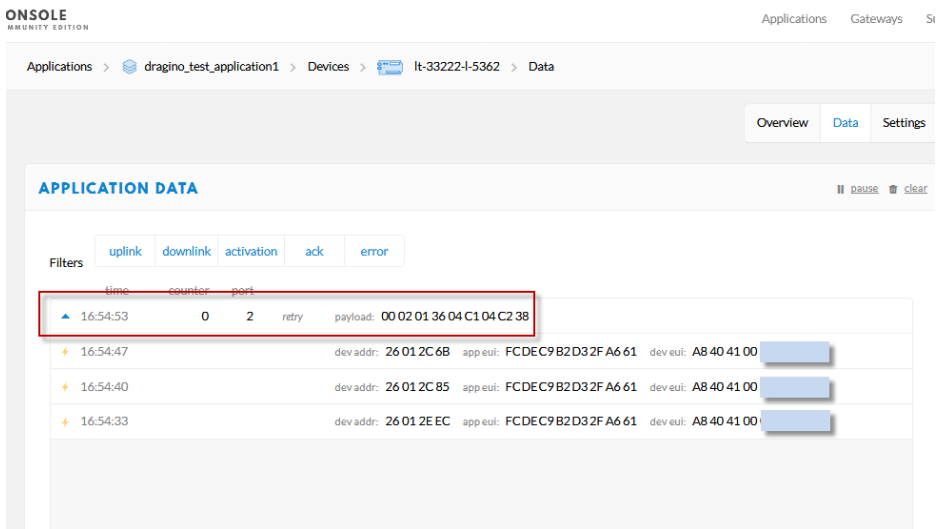

5. Web Configure Pages

5.1 Home

Shows the system running status:

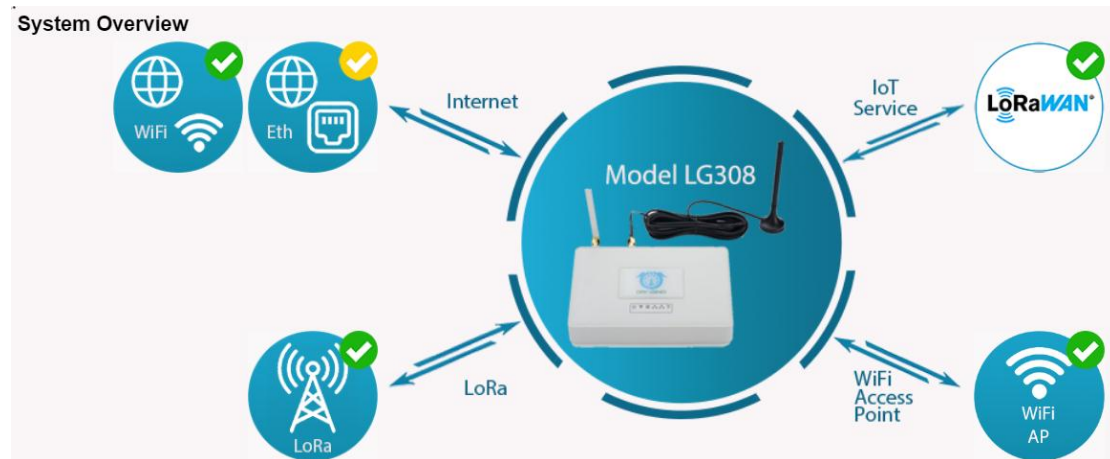

5.2 LoRa Settings

5.2.1 LoRa --> LoRa

This page shows the LoRa Radio Settings. There are a set of default frequency band according to LoRaWAN protocol, and user can customized the band* as well.

Different LG308 hardware version can support different frequency range:

- **868**: valid frequency: 863Mhz ~ 870Mhz. for bands EU868, RU864, IN865 or KZ865.
- **915**: valid frequency: 902Mhz ~ 928Mhz. for bands US915, AU915, AS923 or KR920

After user choose the frequency plan, he can see the actually frequency in used by checking the page **LogRead --> LoRa Log**

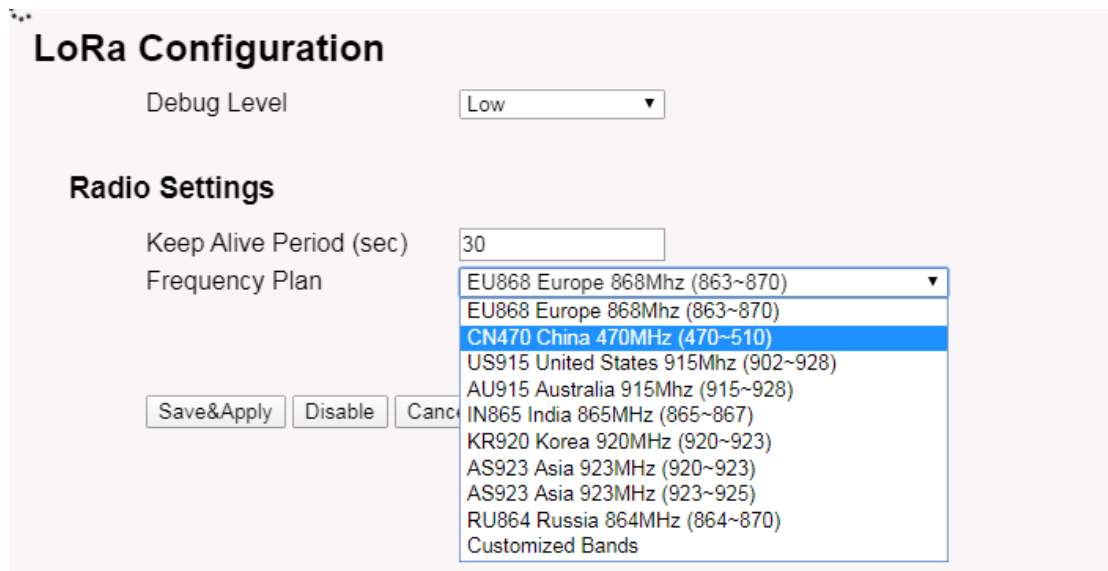

LoRa Configuration

Debug Level:

Radio Settings

Keep Alive Period (sec):

Frequency Plan:

- EU868 Europe 868Mhz (863~870)
- EU868 Europe 868Mhz (863~870)
- CN470 China 470MHz (470~510)**
- US915 United States 915Mhz (902~928)
- AU915 Australia 915Mhz (915~928)
- IN865 India 865MHz (865~867)
- KR920 Korea 920MHz (920~923)
- AS923 Asia 923MHz (920~923)
- AS923 Asia 923MHz (923~925)
- RU864 Russia 864MHz (864~870)
- Customized Bands

Note *: See this instruction for how to customize frequency band:

http://wiki.dragino.com/index.php?title=Customized_Frequency_Band_for_Gateway

5.2.2 LoRa --> ABP Decryption

The LG308 can communicate with LoRaWAN ABP End Node without the need of LoRaWAN server. It can be used in some cases such as:

- No internet connection.
- User wants to get data forward in gateway and forward to their server based on MQTT/HTTP, etc. (Combine ABP communication method and MQTT forward together).

Detail of this feature:

http://wiki.dragino.com/index.php?title=Communication_with_ABP_End_Node

Decrypt ABP End Node Packets

Enable ABP Decryption

Add Key

Dev ADDR:
APP Session Key:
Network Session Key:

Delete Key

Dev ADDR:

ABP Keys:

Dev ADDR	APP Session Key	Network Session Key
----------	-----------------	---------------------

5.3 LoRaWAN Settings

5.3.1 LoRaWAN --> LoRaWAN

This page is for the connection set up to a general LoRaWAN Network server such as: [TTN](#), [ChirpStack](#) etc

LoRaWAN Configuration

Server Settings

LoRaWAN Service Provider	<input type="text" value="TTN-router-EU"/>		
Gateway ID	<input type="text" value="a84041ffff1d25dc"/>		
Server Port Upstream	<input type="text" value="1700"/>	Latitude	<input type="text" value="22.705177"/>
Server Port Downstream	<input type="text" value="1700"/>	Longitude	<input type="text" value="114.243423"/>
Email	<input type="text" value="dragino-1d25dc@dragino.com"/>		

Packet Filter

Port Filter

Note

** : Packet filter is to drop the unwanted LoRaWAN packet, instruction see here:

See http://wiki.dragino.com/index.php?title=Main_Page#Filter_unwanted_LoRaWAN_packets

5.3.2 LoRaWAN --> LORIoT

Settings to communicate to LORIoT LoRaWAN Network Server: <https://www.loriot.io/>

Instruction: http://wiki.dragino.com/index.php?title=Notes_for_LORIoT

LORIoT Client Configuration

LORIoT software not installed.

Server Address	<input type="text" value="Sydney - au1.loriot.io"/>	Server Port	<input type="text" value="Default"/>
Client Certificate	<input type="text"/>	Client Key	<input type="text"/>
CA File	<input type="text"/>		

Device EUI: A840411D25DF

[Certificate Management](#)

5.4 MQTT Settings

If end nodes works in ABP mode, user can configure LG308 to transfer the data to MQTT broker, Instruction:

http://wiki.dragino.com/index.php?title=Main_Page#MQTT_Forward_Instruction

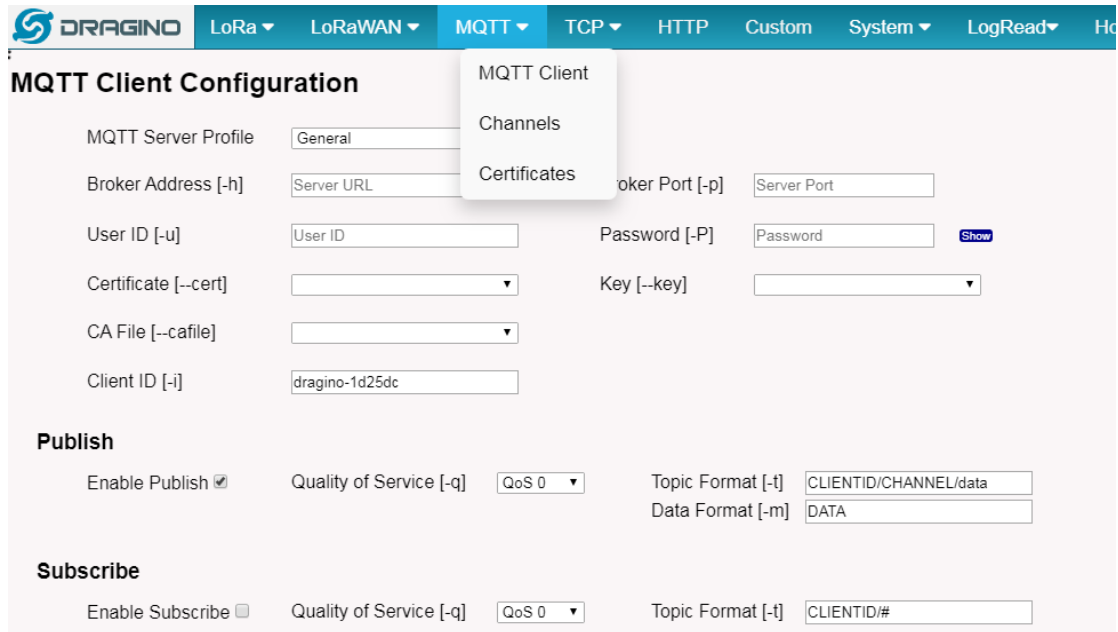

MQTT Client Configuration

MQTT Server Profile: General

Broker Address [-h]: Server URL

Broker Port [-p]: Server Port

User ID [-u]: User ID

Password [-P]: Password Show

Certificate [--cert]:

Key [--key]:

CA File [--cafile]:

Client ID [-i]: dragino-1d25dc

Publish

Enable Publish

Quality of Service [-q]: QoS 0

Topic Format [-t]: CLIENTID/CHANNEL/data

Data Format [-m]: DATA

Subscribe

Enable Subscribe

Quality of Service [-q]: QoS 0

Topic Format [-t]: CLIENTID/#

5.5 System

5.5.1 System --> System Overview

Shows the system info:

System Overview

Firmware: Dragino-v2 LG02_LG08-5.4.1592278488

System: "OpenWrt 18.06-SNAPSHOT r5-ce45a50"

Hostname: dragino-1d25dc

Device Model: DLOS8

System Time: Tue Jun 16 06:24:30 UTC 2020

Uptime: 27 min

Load Avg: 0.40, 0.51, 0.43

Memory: Free Memory: 27984 / Total Memory: 60192kB

IoT Service: lorawan

Internet Connection OK 

LoRaWAN Connection OK 

5.5.2 System --> General (login settings)

System General

System Password

Password Show SetPassword Login: root
 Password (admin) Show SetAdminPassword

TimeZone

Timezone

Port Forwarding

Enable HTTP Forward
 Enable SSH Forward

System Password:

There are two login for DLOS8: **root /dragino** or **admin /dragino**. Both root and admin has the same right for WEB access. But root user has also the right to access via SSH to Linux system. admin only able to access WEB interface.

This page can be used to set the password for them.

Timezone:

Set device timezone.

Port forwarding:

Enable/Disable the HTTP and SSH access via WAN interface.

5.5.3 System --> Network

Network

LAN Settings

IP Address	<input type="text" value="10.130.1.1"/>	Gateway	<input type="text" value="255.255.255.255"/>
Netmask	<input type="text" value="255.255.255.0"/>	DNS	<input type="text" value="8.8.8.8"/>

WAN Settings

Enable DHCP

WiFi WAN Settings

Enable DHCP

LAN Settings:

When the LG308 has the AP enable, LAN settings specify the network info for LG308's own network.

WAN Settings:

Setting for LG308 WAN port

WiFi Settings:

Setting for LG308 WiFi IP when use it as WiFi Client

5.5.4 System --> WiFi

LG308 WiFi Settings.

WiFi

Radio Settings

Channel (1-11) Tx Power (0-18) dBm

WiFi Access Point Settings

Enable WiFi Access Point

WiFi Name SSID

Passphrase (8-32 char) [Show](#) Encryption

WiFi WAN Client Settings

Enable WiFi WAN Client

Host WiFi SSID

Passphrase [Show](#) WiFi Survey

Encryption

5.5.5 System --> Cellular

While use the cellular as Backup WAN, device will use Cellular for internet connection while WAN port or WiFi is not valid and switch back to WAN port or WiFi after they recover.

Cellular Settings

Enable Cellular WAN

Use Cellular as Backup WAN

APN

Service

Dial Number

Pincode

Username

Password [Show](#)

Note *: For LG308 which doesn't have the cellular module, this page will shows Cellular not detected.

5.5.6 System --> Network Status

System Status

Network / WiFi Status

```
Network
-----
Lan IP Address:
inet addr:10.130.1.1 Bcast:10.130.1.255 Mask:255.255.255.0

Eth WAN IP Address:
inet addr:10.130.2.207 Bcast:10.130.2.255 Mask:255.255.255.0
inet addr:172.31.255.254 Bcast:172.31.255.255 Mask:255.255.255.252
WiFi WAN IP Address:
Cellular:

Bridge:
bridge name bridge id          STP enabled interfaces
br-lan      7fff.a840411d25df    no          eth0
                               wlan0

WiFi
----
wlan0  ESSID: "dragino-1d25dc"
       Access Point: A8:40:41:1D:25:DC
       Mode: Master Channel: 11 (2.462 GHz)
       Tx-Power: 17 dBm Link Quality: unknown/70
       Signal: unknown Noise: -95 dBm
       Bit Rate: unknown
       Encryption: WPA2 PSK (CCMP)
       Type: nl80211 HW Mode(s): 802.11bgn
```

5.5.7 System --> Remote Mgmt

R-SSH is for remote access device and management, introduction for how to use:

http://wiki.dragino.com/index.php?title=Main_Page#Remote_Access_Gateway_via_Reverse_SSH

R-SSH Host Settings

Login ID

Host Address Host Port

Connect at Startup GWID: a84041ffff1d25dc

Connection Status: **Not connected to RSSH Host**

Note: Auto connection after startup may take up to 5 minutes to clear previous connection

Generate New Keys

Current Key ID: **No keyfile present**

Caution: Generating new keys will break any existing server connections!!

[Download Public Key](#)

5.5.8 System --> Firmware Upgrade

We keep improving the LG308 Linux side firmware for new features and bug fixes. Below are the links for reference.

- **Latest firmware:** [LoRa Gateway Firmware](http://www.dragino.com/downloads/index.php?dir=LoRa_Gateway/LG02-OLG02/Firmware),
(http://www.dragino.com/downloads/index.php?dir=LoRa_Gateway/LG02-OLG02/Firmware)
- **Change Log:** [Firmware Change Log](http://www.dragino.com/downloads/downloads/LoRa_Gateway/LG02-OLG02/Firmware/ChangeLog).
(http://www.dragino.com/downloads/downloads/LoRa_Gateway/LG02-OLG02/Firmware/ChangeLog)

The file named as **xxxxx-xxxxx-squashfs-sysupgrade.bin** is the upgrade Image. There are different methods to upgrade, as below.

Web → System → Firmware Upgrade

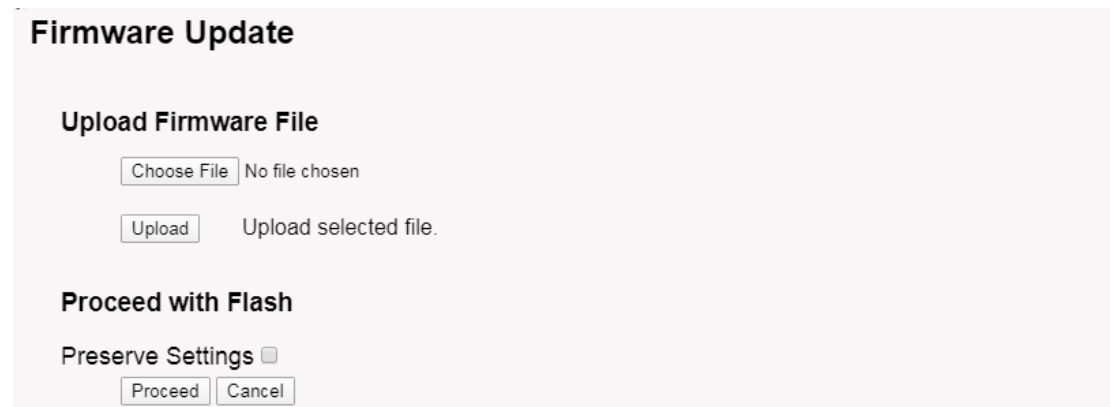

The screenshot shows a web interface titled "Firmware Update". It contains two main sections:

- Upload Firmware File:** This section has a "Choose File" button next to the text "No file chosen". Below it is an "Upload" button next to the text "Upload selected file."
- Proceed with Flash:** This section has a "Preserve Settings" checkbox which is currently unchecked. Below the checkbox are two buttons: "Proceed" and "Cancel".

Select the required image and click **Flash Image**. The image will be uploaded to the device, and then click **Process Update** to upgrade.

NOTE: You normally need to **uncheck** the **Preserve Settings** checkbox when doing an upgrade to ensure that there is no conflict between the old settings and the new firmware. The new firmware will start up with its default settings.

The system will automatically boot into the new firmware after upgrade.

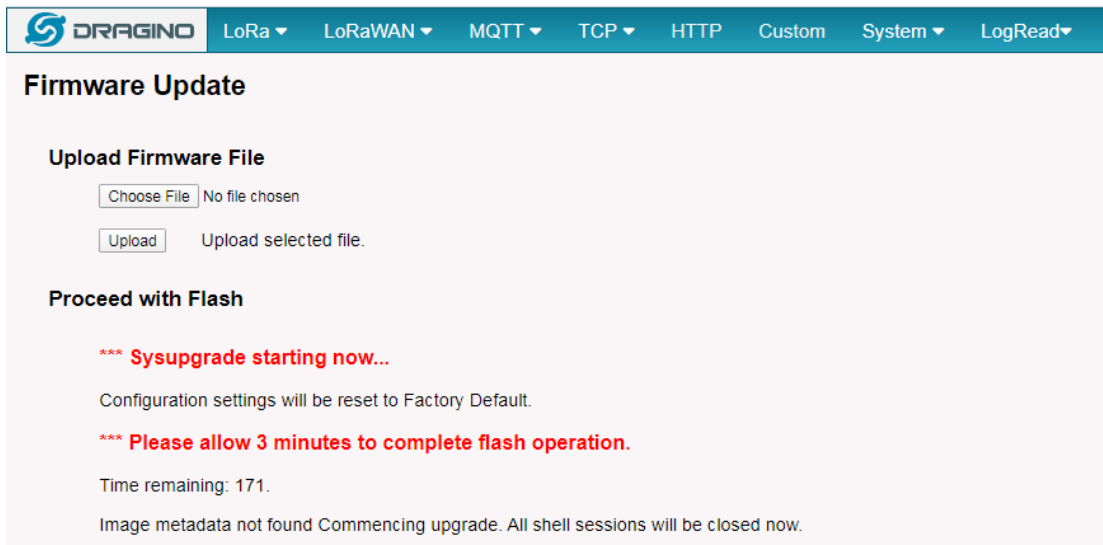

Note *: User can also upgrade firmware via Linux console
SCP the firmware to the system **/var** directory and then run

```
root@OpenWrt:~# /sbin/sysupgrade -n /var/Your_Image
```

NOTE: it is important to transfer the image in the /var directory, otherwise it may exceed the available flash size.

5.5.9 System --> Reboot/Reset

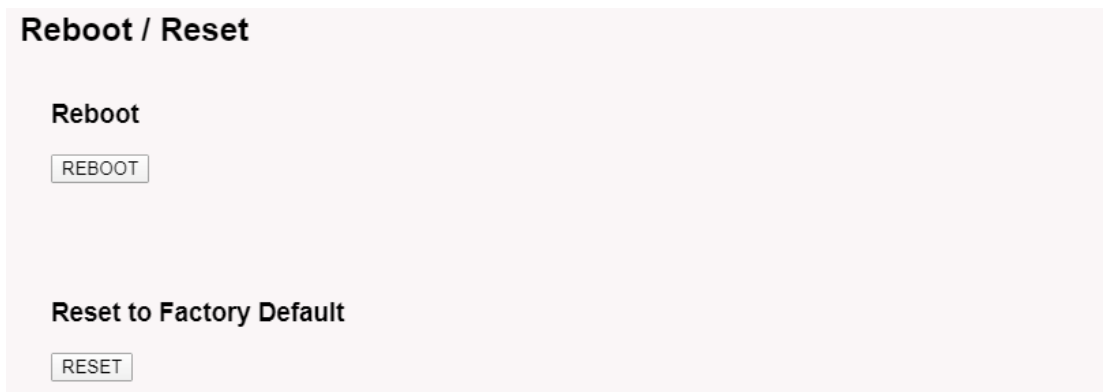

5.5.10 System --> Package Maintain

Package Management

Package List

Package data is not loaded. Click on Reload to download package data.

Click Reload to download package list. This will take a while.

Installed Package List

```
atftp - 0.7.1-5
base-files - 190-r5-ce45a50
blkid - 2.32.2
block-mount - 2018-04-16-e2436836-1
busybox - 1.28.3-4
ca-certificates - 20180409
chat - 2.4.7-17
```

Place to show what package has installed and possible to upgrade packages.

5.6 LogRead

5.6.1 LogRead --> LoRa Log

```

LogRead

FreqINFO:
SX1301 Channels frequency
-----
chan_multSF_0
Lora MAC, 125kHz, all SF, 868.1 MHz
-----
chan_multSF_1
Lora MAC, 125kHz, all SF, 868.3 MHz
-----
chan_multSF_2
Lora MAC, 125kHz, all SF, 868.5 MHz
-----
chan_multSF_3
Lora MAC, 125kHz, all SF, 867.1 MHz
-----
chan_multSF_4
Lora MAC, 125kHz, all SF, 867.3 MHz
-----
chan_multSF_5
Lora MAC, 125kHz, all SF, 867.5 MHz
-----
chan_multSF_6

```

Show the frequency for LoRa Radio and traffics.

5.6.2 LogRead --> System Log

Show the system log

```

System Log

USB Devices:
Bus 001 Device 003: ID 0403:6001 Future Technology Devices International, Ltd FT232 Serial (UART) IC
Bus 001 Device 002: ID 1a40:0101 Terminus Technology Inc. Hub
Bus 001 Device 001: ID 1d6b:0002 Linux Foundation 2.0 root hub

Boot Info:
Linux version 4.9.109 (root@DraginoHK) (gcc version 7.3.0 (OpenWrt GCC 7.3.0 r7360-e15565a)) #0 Fri Jun 29 16:58:53 2018
MyLoader: syap=aaaaaaaa, boardp=2aabaab, parts=aaaa2aab
bootconsole [early0] enabled
CPU0 revision is: 00019374 (MIPS 24Kc)
SoC: Atheros AR9330 rev 1
Determined physical RAM map:
memory: 04000000 @ 00000000 (usable)
initrd not found or empty - disabling initrd
Primary instruction cache 64kB, VIPT, 4-way, linesize 32 bytes.
Primary data cache 32kB, 4-way, VIPT, cache aliases, linesize 32 bytes

Previous Log:

```

6. More features

6.1 More instructions

http://wiki.dragino.com/index.php?title=Main_Page#LoRa.2FLoRaWAN_Gateway_Instruction

7. Linux System

The LG308 bases on OpenWrt Linux System. It is open source, and user are free to configure and modify the inside Linux settings.

7.1 SSH Access for Linux console

User can access to the Linux console via SSH protocol. Make sure your PC and the LG308 is in the same network, then use a SSH tool (such as [putty](#)) to access it. Below are screenshots:

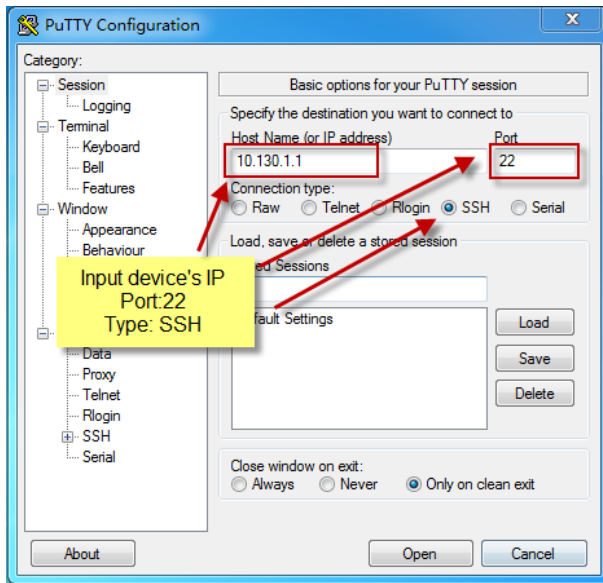

IP address: IP address of LG308
 Port: 22 or 2222
 User Name: **root**
 Password: **dragino** (default)

After log in, you will be in the Linux console and type command here.

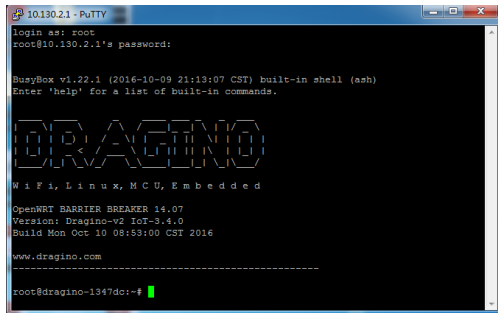

The "logread -f" command can be used to debug how system runs.

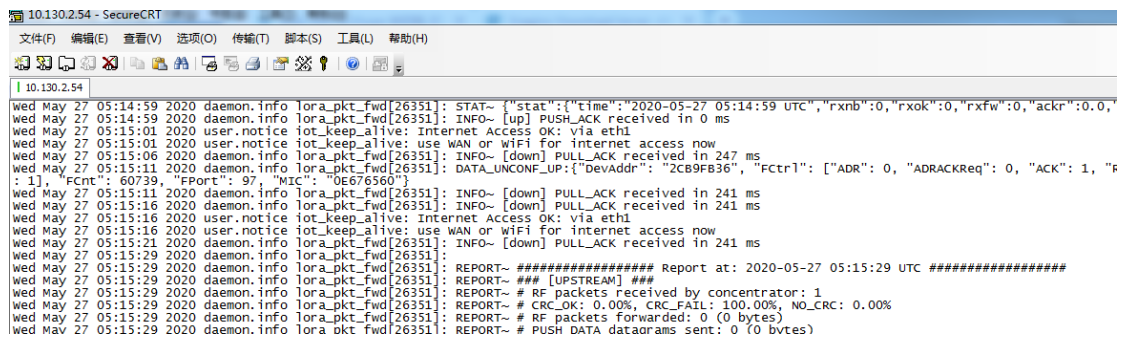

7.2 Edit and Transfer files

The LG308 support **SCP protocol** and has a built **SFTP server**. There are many ways to edit and transfer files using these two protocols. One of the easiest is through [WinSCP](#) utility. After access via WinSCP to the device, use can use a FTP alike window to drag / drop files to the LG308 or Edit the files directly in the windows. Screenshot is as below:

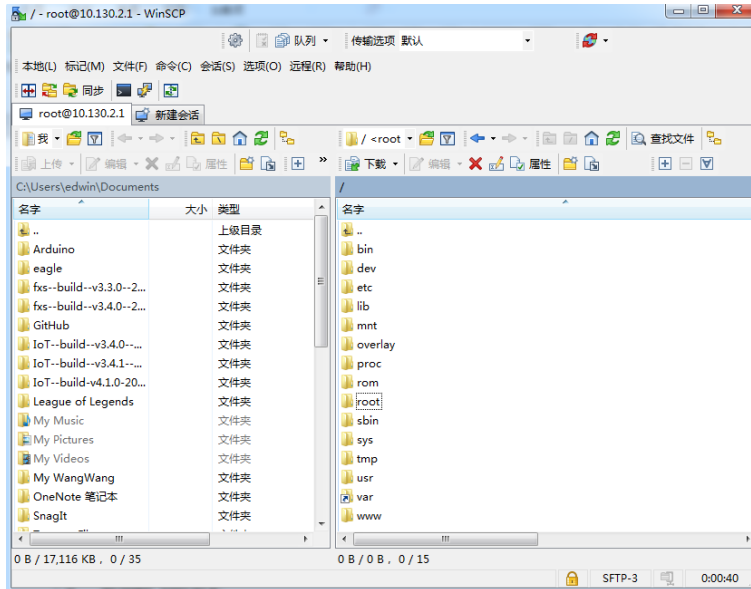

7.3 File System

The LG308 has a 16MB flash and a 64MB RAM. The /var and /tmp directory are in the RAM, contents stored in /tmp and /var will be erased after reboot the device. Other directories are in the flash and will keep after reboot.

The Linux system use around 8MB ~10MB flash size which means there is not much room for user to store data in the LG308 flash. User can use an external USB flash to extend the size for storage.

7.4 Package maintain system

LG308 uses [OPKG package maintain system](#). There are more than 3000+ packages available in our package server for user to install for their applications. For example, if user wants to add iperf tool, they can install the related packages and configure LG308 to use iperf

Below is some examples opkgs command, more please refer [OPKG package maintain system](#)

In Linux Console run:

```
root@dragino-169d30:~# opkg update // to get the latest packages list
```

```
root@dragino-169d30:~# opkg list //shows the available packages
```

```
root@dragino-169d30:~# opkg install iperf // install iperf, it will auto install the required packages.
```

```
root@dragino-169d30:/etc/opkg# opkg install iperf
```

```
Installing iperf (2.0.12-1) to root...
```

```
Downloading http://downloads.openwrt.org/snapshots/packages/mips_24kc/base/iperf_2.0.12-1_mips_24kc.ipk
```

```
Installing uclibcxx (0.2.4-3) to root...
```

```
Downloading
```

```
http://downloads.openwrt.org/snapshots/packages/mips_24kc/base/uclibcxx_0.2.4-3_mips_24kc.ipk
```

```
Configuring uclibcxx.
```

```
Configuring iperf.
```

8. Upgrade Linux Firmware

9. FAQ

9.1 How can I configure for a customized frequency band?

See below link for how to customize frequency band:

[http://wiki.dragino.com/index.php?title=Customized Frequency Band for Gateway](http://wiki.dragino.com/index.php?title=Customized_Frequency_Band_for_Gateway)

9.2 Can I connect DLOS8 to LORIoT?

Yes, the set up instruction is here:

[http://wiki.dragino.com/index.php?title=Notes for LORIoT](http://wiki.dragino.com/index.php?title=Notes_for_LORIoT)

9.3 Can I make my own firmware for the gateway, where can I find the source code?

Yes, You can make your own firmware for the DLOS8 for branding purposes or to add customized applications.

The source code and compile instructions can be found at:

https://github.com/dragino/openwrt_lede-18.06

9.4 Can I use 868Mhz version for 915Mhz bands?

It is possible but the distance will be very short, you can select US915 frequency band in 868Mhz version hardware. It will work but you will see the performance is greatly decreased because the 868Mhz version has an RF filter for band 863~870Mhz, all other frequencies will have high attenuation.

9.5 Can I control the LEDs?

Except the PWR LED is controlled by +3v3 power directly. All other LEDs can be controlled by developer.

Control Globe LED:

ON: `echo 1 > /sys/class/leds/dragino2\:red\:wlan/brightness`

OFF: `echo 0 > /sys/class/leds/dragino2\:red\:wlan/brightness`

Control HEART LED:

First export the gpio27 and set to out

`echo 27 > /sys/class/gpio/export`

`echo out > /sys/class/gpio/gpio27/direction`

ON: `echo 0 > /sys/class/gpio/gpio27/value`

OFF: `echo 1 > /sys/class/gpio/gpio27/value`

10. Trouble Shooting

10.1 I get kernel error when install new package, how to fix?

In some case, when install package, it will generate kernel error such as below:

```
root@dragino-16c538:~# opkg install kmod-dragino2-si3217x_3.10.49+0.2-1_ar71xx.ipk
```

```
Installing kmod-dragino2-si3217x (3.10.49+0.2-1) to root...
```

```
Collected errors:
```

```
* satisfy_dependencies_for: Cannot satisfy the following dependencies for
```

```
kmod-dragino2-si3217x:
```

```
* kernel (= 3.10.49-1-4917516478a753314254643facdf360a) *
```

```
* opkg_install_cmd: Cannot install package kmod-dragino2-si3217x.
```

In this case, user can use the `--force-depends` option to install such package.

```
opkg install kmod-dragino2-si3217x_3.10.49+0.2-1_ar71xx.ipk --force-depends
```

10.2 How to recover the LG308 if firmware crash

Please follow this instruction to recover your gateway:

http://wiki.dragino.com/index.php?title=Recover_Gateway

10.3 I configured LG308 for WiFi access and lost its IP. What to do now?

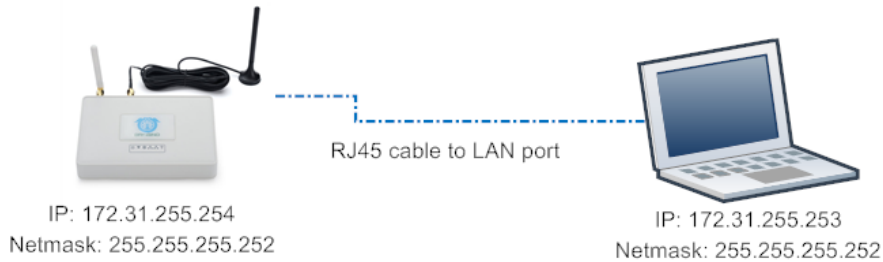

The LG308 has a fall-back ip in its LAN port. This IP is always enabled so user can use fall back ip to access LG308 no matter what the WiFi IP is. The fall back ip is useful for connect and debug the unit.

(Note: fallback ip can be disabled in the LAN and DHCP page)

Steps to connect via fall back IP:

1. Connect PC's Ethernet port to LG01's LAN port
2. Configure PC's Ethernet port has IP: 172.31.255.253 and netmask: 255.255.255.252

As below photo:

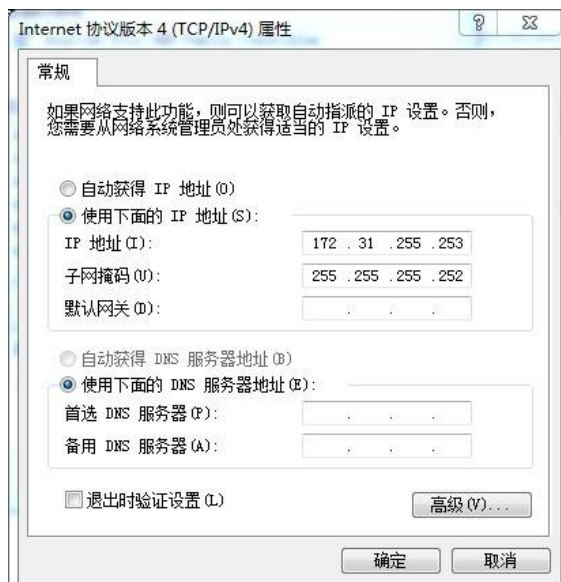

3. In PC, use 172.31.255.254 to access LG308 via Web or Console.

11. Order Info

PART: LG308-XXX-YYY:

XXX: Frequency Band

- **868**: valid frequency: 863Mhz ~ 870Mhz. for band EU868 or IN865.
- **915**: valid frequency: 902Mhz ~ 928Mhz. for bands US915, AU915, AS923 or KR920

YYY: 4G Cellular Option

- **EC25-E**: EMEA, Korea, Thailand, India.
- **EC25-A**: North America/ Rogers/AT&T/T-Mobile.
- **EC25-AU**: Latin America, New Zeland, Taiwan
- **EC25-J**: Japan, DOCOMO/SoftBank/ KDDI

More info about valid bands, please see [EC25-E product page](#).

12. Packing Info

Package Includes:

- ✓ LG308 or LG08 LoRa Gateway x 1
- ✓ Stick Antenna for LoRa RF part. Frequency is one of 433 or 868 or 915Mhz depends the model ordered
- ✓ Power Adapter: EU/AU/US type power adapter depends on country to be used
- ✓ Packaging with environmental protection paper box

Dimension and weight:

- ✓ Device Size: 12 x 8.5 x 3 cm
- ✓ Device Weight: 150g
- ✓ Package Size / pcs : 21.5 x 10 x 5 cm
- ✓ Weight / pcs : 360g
- ✓ Carton dimension: 45 x 31 x 34 cm. 36pcs per carton
- ✓ Weight / carton : 12.5 kg

13. Support

- Try to see if your questions already answered in the [wiki](#).
- Support is provided Monday to Friday, from 09:00 to 18:00 GMT+8. Due to different timezones we cannot offer live support. However, your questions will be answered as soon as possible in the before-mentioned schedule.
- Provide as much information as possible regarding your enquiry (product models, accurately describe your problem and steps to replicate it etc) and send a mail to

support@dragino.com

14. Reference

- ✧ Source code for LG08 LoRa Gateway
https://github.com/dragino/openwrt_lede-18.06

- ✧ OpenWrt official Wiki
<http://www.openwrt.org/>

- ✧ Firmware
http://www.dragino.com/downloads/index.php?dir=LoRa_Gateway/LG308-OLG308/Firmware/

- ✧ Hardware Source code:
<https://github.com/dragino/motherboard-hardware/tree/master/LG308>